



HPOIL GAS PRIVATE LIMITED
(A Joint Venture of HPCL & OIL)

**ANNUAL RATE CONTRACT FOR LAYING OF PE PIPELINE NETWORK
& ABOVEGROUND INSTALLATIONS FOR INDUSTRIAL &
COMMERCIAL PNG CONNECTIONS AT KOLHAPUR GA**

TECHNICAL VOLUME

TENDER NO. HOGPL/2026-27/C&P/014

DATE: 12.06.2026

TABLE OF CONTENTS

1.0 INTRODUCTION3

2.0 PURPOSE3

3.0 DEFINITIONS.....3

4.0 DOCUMENT PRECEDENCE4

5.0 SCOPE OF WORK4

Part II: MDPE Service Line.....10

Part III: GI Installation11

6.0 CONDITIONS FOR ISSUE OF MATERIALS.....13

7.0 RECONCILIATION OF OWNER SUPPLIED MATERIALS.....13

1.0 INTRODUCTION

HPOIL Gas Private limited (HOGPL) consortium of HPCL & OIL has received the authorization from PNGRB vide letter PNGRB vide letter PNGRB/CGD/BID/8/2018/GA/Ambala-Kurukshetra District dated 22/02/2018 and PNGRB/CGD/BID/8/2017/BEC/GA-Kolhapur dated 06/03/2018, to Lay, Build and Operate City Gas Distribution networks in Ambala-Kurukshetra and Kolhapur District. HOGPL (hereinafter referred as Owner), is supplying Piped Natural Gas (PNG) to domestic, commercial, and Industrial consumers and Compressed Natural Gas (CNG) to automobiles in Ambala-Kurukshetra and Kolhapur District.

The present document covers the technical specifications for the enquiry.

2.0 PURPOSE

This document is for the scope of hire contractor GI installation work, MDPE Service Line Laying & Direct Marketing Services at Kolhapur GA.

3.0 DEFINITIONS

Where used in this document, the following terms shall have the meanings indicated below, unless clearly indicated by the context to this order:

PROJECT	LAYING OF UNDERGROUND PE PIPELINE NETWORK & ABOVEGROUND INSTALLATIONS FOR PNG CONNECTIONS AT KOLHAPUR GA
OWNER	HPOIL GAS PRIVATE LIMITED (HOGPL)
MANUFACTURER	The party, which manufactures and supplies equipment and services to the OWNER or to Contractor (for supply materials required for execution of work as per SOR).
SOW	SCOPE OF WORK
CONTRACTOR / BIDDER	The party, which has awarded the tender for the execution of work at site including supply, installation and commissioning (if any) of materials required for completion of Work.

4.0 DOCUMENT PRECEDENCE

It shall be the responsibility of the Contractor/ Bidder to inform the OWNER of any errors, ambiguities, inconsistencies, discrepancies, or conflict of information that may be found to exist in any document, specification or drawing provided in the tender by the OWNER.

In case of conflict, the order of precedence shall be as follows:

- a. Scope of Work (SOW)
- b. Schedule of Rates (SOR)
- c. Data Sheets & QAP
- d. Standard Specifications
- e. Codes and Standards

As a general rule in the event of any discrepancy between technical matter and local laws/ regulations (and documents above listed) the most stringent shall be applied.

CONTRACTOR/ BIDDER shall notify OWNER of any apparent conflicts between SOW, Technical specifications, related datasheets, any code and standards and any other specifications noted herein. (Resolution and/ or interpretation precedence shall be obtained from OWNER in writing before proceeding with the design/ manufacturer or completion of services.)

5.0 SCOPE OF WORK

The main scope of work comprises laying, testing, and commissioning of underground service pipelines network of sizes ranging from 20mm up to 32mm Dia. along with above ground GI pipe installation (LMC) and Direct Marketing Services for PNG Connections to Industrial & Commercial consumers for City Gas Distribution project. The scope also covers all the activities associated with the supply of materials (except free issue items).

OWNER'S SCOPE OF SUPPLY (FREE ISSUE ITEM).

- PE Pipes of sizes from 20mm up to 32mm Dia. along with Meter & Meter Regulators.
- GI pipe, Isolation Valve up to size of ¾"

CONTRACTOR'S SCOPE OF WORK

Supplied by the contractor

- Supply of PE fittings & Half Concrete Sleeves and transition fittings of sizes from 63 mm to 20 mm.
- Supply of GI fittings of all sizes.
- Supply of Powder coated GI pipes of size 1" and all its associated fittings including Meter Brackets.
- Supply of Rubber hose and all materials required for natural gas conversion.
- Supply of warning mat.

- Supply of Isolation valve of size 1”.
- Supply of CS pipes, valves, flanges and associated fittings.
- All PPE materials required for safe execution of projects.
- As other materials required for smooth execution of project over and above as mentioned.

Bidder is advised to refer each SOR line item for clarity on Free Issue Materials & materials required to be supplied by contractor. All above supply quantity as per relevant SOR item and shall be procured from owners approved vendors only after approval from HOGPL/VCS & as per instruction of Engineer-in-charge (EIC).

Generally, the following shall constitute the contractor's scope of work but not limited to:

1. Contractor to provide Work Implementation & Execution plan along with a schedule for execution and work implementation as per QA/QC plans to be issued by Owner/ Owner's representative. Contractor has to submit the Construction/ Execution procedures before commencement of work to Owner/ Owner's representative for approval.
2. Prior to start of construction activity, contractor shall carry out the route survey and prepare the approval for construction (APC) drawings marked for proposed gas pipe line laying and submit to OWNER/ PMC for approval. The standard templates and color coding as per Owners standard.
3. Co-ordination/ Liaison from respective land-owning agencies such as Municipal Corporation, CPWD, ADA/ LDA, Nagar Nigam, PWD-NH, NHAI, Indian Railway, Forest & Environment Department, Irrigation department, MIDC and other land owning agencies for road cutting for laying of the pipelines, Liaison with the concerned authorities during execution of the job, obtaining NOC from concerned authorities once the work is completed. Getting back/refund of bank guarantee/ security deposits made to the agencies for laying of the pipelines.
4. For MDPE laying (Mainline/4 Bar pressure) construction purposes, in Kolhapur GA pipeline restricted ROU / Corridor and ROU acquisition / principal permission from respective OWNER's like CMC, KIADB, BIA, KRDC, PMRDA, ZP, MIDC, Municipal Council, Nagarpanchyat, Grampanchyat, NHAI , PWD, Railway, Metro, Private land owner (if required) etc. for laying the pipeline including permission for all crossing i.e. rail, road, river, foreign hydrocarbon & utility pipelines, utility cables etc. and day to day coordination on site during execution, will be in the scope of contractor.
5. Obtaining clearances and coordination with concerned RWA of the allotted area for internal network laying and obtaining NOC from RWA after completion of work.
6. Transportation of Free Issue material from OWNER stores to contractor stores and proper storing, stacking, providing security, insurance cover during transportation and storage, laying, commissioning and handing over pipelines to owner.
7. Obtaining the approval for optimum route and ROU from the concerned authority and EIC.
8. Intimation to the parallel utilities (Electrical/ Communication/ Water) owners and making trial pits to determine the underground utilities/services such as existing pipelines, cables (electrical/ communication), conduits, U/G drainage, Sewers, tunnels, subways foundations etc. for deciding optimum feasible route and depths for laying the pipelines based on the route plans indicated by owner.
9. Contractor must arrange road cutter machine for all areas where road cut need

to be done.

10. Wherever required the grass/ turfing, pavement, linings, drains, roads and other such 'pucca' area shall be locally removed to facilitate trenching and pipe laying works. The same is to be reinstated as original.
11. Installation of safety/warning signs and barricading of the entire route to be trenched. Pits to be similarly barricaded along with warning signs and caution boards. Photograph of each trench with geostamp and timestamp required after laying, placing warning mat and restoration respectively.
12. To make trenches with stable slopes but restricting minimum disturbance to above ground/underground services/installation as per specifications and approved route plans keeping the trenches free from water and soil till placement of pipes.
13. Uncoiling/stringing the MDPE pipes of required sizes (i.e. 32 & 20 mm) pipes into trenches as per approved procedure.
14. Supply and Installation of MDPE pipe Rest material and fittings like Elbow, Tees, Reducers, Couplers, tapping saddles, Transition fittings, End cap and Sleeves etc. including construction of supports, Valves pits, Inspection chambers etc. as per specification, drawing & satisfaction of the Engineer in charge (EIC).
15. Joining the pipe ends with fittings of valves by approved automated electro-fusion techniques only as per tender specification.
 - EF welding machine should be one which provides GPS coordinate similar to GF++ MSA 340 or equivalent machine.
 - EF operator to be deployed for EF welding must be certified from approved vendors of EF fittings manufacturer like GF/ Kimplas/ Section IX of ASME BPV.
 - Contractor obtain latest welder I-Card by getting training from approved agencies with practical knowledge of welding on highest dia. on which work is intended.
 - Contractor arrange to have reports of destructive testing of GI fittings for a lot every six months at its own cost to ensure the quality of GI fittings as per instructions of EIC.
16. Laying pipelines by any methodology including trench less technology methods with or without casing pipes (HDPE pipes) as per specifications and as directed by EIC.
17. Photos and videos with accurate geo reference and time stamp during lowering need to be captured by contractor and GPS Coordinates/ points to be mentioned in lowering report for each EF joint. Site Photographs for before and after scenarios showing trenching, its barricades and restoration to be captured with geo co-ordinates and time stamp.
18. Contractor must take geostamped and time stamped photo of each EF welded joint and submit for Project in charge records on daily basis. Only hydraulic squeezers are allowed and re-rounding tools are required.
19. Installation of pipes (by open cut/ Moling/ HDD) assembly, including supply of all materials (excluding free issue material if any) viz. as per the drawings/ specifications enclosed with bid package. HDD methodology and its profile

submission prior to execution of HDD should be in contractor scope. Also, route marker installation at 100m should be integral part of laying.

20. Moling should be done with Teflon coated crow bar extension only and with proper ventilation in Moling pit. Electrical utility to be identified prior to attempting manual boring. Following equipment to be deployed on site by the contractor:
 - Squeeze Tools.
 - Gas Detection Unit and Cable locator -1 each in place
 - Pipe Straightness and re-rounding tool -1 each
21. Contractor should submit following set of daily reports (Planning, Manpower, Material Inventory, DPR) and monthly reports (QC, Meter reconciliation, material reconciliation, DPR, etc.) Contractor should submit daily site wise activity geostamped and timestamped photos to Engineer in Charge.
22. Contractor must also have to arrange his own equipment like water tanker for Water showering on construction site (trench valves pit areas).
23. Contractor to depute Store keeper and draftsmen for each GA. 1 supervisor required for each site area. 1 HSE person required for GA.
24. Fabrication, supply and inspection of approved quality GI sleeve, HDPE duct and half concrete sleeves and other material, fittings to be supplied by the contractors as per the provisions of tender.
25. Back filling and compaction by jumping jack compactor wherever required, using approved 'good' soil or using excavated earth or borrow earth as per requirement and specifications and replacement of the tiles, slabs removed during the excavation. Cleaning all unserviceable materials, debris, excess earth trenches etc. to designated disposal area.
26. The contractor shall be responsible to arrange the supply of approved coarse sand (size 0.6 - 2 mm as per IS 383) free from any impurities like clay, mica, and soft flaky pieces, as per the instructions of EIC /Owner's representative.
27. Sand / soft soil padding around pipe wherever required in areas where trenching has been done in hard soil area / rocky area including supply of sand/ soft soil. The thickness of sand/ soft soil padding at the top of coated pipe shall be minimum 150 mm and bottom of coated pipe shall be minimum 150 mm or as per standard drawing.
28. Carrying out pneumatic testing and purging as per specifications and approved procedures, providing all tools & tackles, instruments, manpower and other related accessories for carrying out the testing of pipes.
29. Supply, fabrication & installation of RCC route marker, Pole marker with foundations, Plate markers, valve chamber etc. as per the directions of the EIC/Owner's representative.
30. Purging should be done to point till Oxygen percentage is less than 2%. Contractor must arrange Purity certificate of N₂ used for purging. It is compulsory to use Nitrogen cylinder trolley while using Nitrogen for purging/ testing. It must be necessary to qualify welder/ manpower for Procedure Qualification Record for performing testing by pressure testing the PE pipe coil.
31. Restoration of existing ground features such as grass/ turfing, paving, roads, drains, concrete, floral beds, fencing, tiles, marbles, flooring masonry etc. to

original condition and to match with adjoining conditions, functionally and aesthetically up to the entire satisfaction of Owner / Owner's representative /any other third party agency designated by owner and local authorities, failing which, it will be done at the risk and cost of the contractor. Obtaining No Objection Certificates for the restoration work done from the concerned authorities.

32. Restoration should be done to satisfaction of EIC and Authority. Contractor must arrange joint site visit report for restoration and submit restoration report.
33. Returning surplus material to Owner stores after obtaining clearance from TPIA/Consultant/ Owner, reconciliation of free issue material/ consumables.
34. Handing over the completed works to owner along with detailed as built drawing showing pipeline route, fittings provided in the pipelines, for their operation purposes. Handing over 3 sets of completed as Built drawings which are GIS compliant. Also required handing over of Non-LMC above ground drawings (including Riser drawings and domestic PNG connections drawings) in editable Auto-Cad as well as PDF format.
35. Maintaining the completed pipelines/installation for any failure and defect arising due to poor workmanship during defect liability period.
36. Preparation and submission of all documents like Pit Wise as graph, As-built drawings, details of crossings, utility graphs, measurement sheet, PE cards for service line and deviation statements on completion/commissioning of work by way of drawing, sketches and tables in soft & hard copy.
37. Providing adequate manpower, tools, tackles, equipment for achieving the target of pipeline laying, data logging for pipeline, valves and fittings inventory status, attending complaints, day to day interaction with customers and residents so that work can be executed within defined time period.
38. Contractors responsibility to provide details as follows (if required): collection of industry details, its current fuel and its consumption and product they manufacture. Identify and locate the collector rate applicable in the particular road in case of NHAI, Forest and Railway. Indicate pipeline route for EIC approval and indicate line sizing after network hydraulics check/ confirmation by EIC. Identify and indicate the name of local authority maintaining the road or drainage/ canal Should provide hard copy of final survey drawing after incorporating all comments from owner's representative.
39. Contractor should identify the name of local authority maintaining the road or drainage/canal & provide hard copy of final survey drawing after incorporating all comments from owner's representative
 - Survey drawing should mention suggested pipeline route in a separate layer for EIC approval before commencing laying.
 - EIC to approve line sizing after network hydraulics check /confirmation in a format and linked to annual budget.
40. Following activities are also in contractor's scope:
 - Receive Customer's complaints logged during MDPE Laying.
 - Attend and carry out joint technical feasibility survey for requests and resolve the complaint.
 - Maintain and update the complaint status.

41. All skilled personnel like jointers, conversion technicians will be approved and certified by EIC based on the test conducted by approved trainers.
42. Contractor shall visit and survey all areas where MDPE laying is planned or in progress to carry out DMA/LMC work in all such areas.

Part I: MDPE Service Line

1. Obtaining the approval for optimum route and permission for work from society management, RWA, individual residents and any other concerned authority, if required, for completion of the work.
2. Selection of route with the EIC/Consultant/TPIA and marking the same on walls/floors from PE network, transition fittings to stove/cooking oven/appliance, making openings and making provisions for fixing clamps. Making temporary but stable platforms/scaffolding/rope/ladder etc., required for installation of pipes/fittings at all heights/multi storied flats and locations.
3. Uncoiling/stringing the MDPE pipes of required sizes (20mm, 32mm) pipes into trenches as per approved procedure.
4. Joining the pipe ends with fittings of valves by approved automated electro-fusion techniques only as per tender specification.
5. Supply and Installation of MDPE pipe fittings like Elbow, Tees, Reducers, Couplers, tapping saddles, Transition fittings, Valves and Sleeves etc. including construction of supports, Valves pits, Inspection chambers etc. as per specification, drawing & satisfaction of the Engineer In charge (EIC).
6. Laying pipelines by any methodology including open cut, trench less technology methods like Moling, HDD, etc.
7. Fabrication, supply and inspection of approved quality GI sleeve, HDPE duct and half concrete sleeves and other material, fittings to be supplied by the contractors as per the provisions of tender.
8. Back filling and compaction by jumping jack compactor wherever required, using approved 'good' soil or using excavated earth or borrow earth as per requirement and specifications and replacement of the tiles, slabs removed during the excavation. Cleaning all unserviceable materials, debris, excess earth trenches etc. to designated disposal area.
9. Carrying out pneumatic testing and purging as per specifications and approved procedures, providing all tools & tackles, instruments, manpower and other related accessories for carrying out the testing of pipes.
10. Restoration of existing ground features such as grass/turfing, paving, roads, drains, concrete, floral beds, fencing, tiles, marbles, flooring masonry etc. to original condition and to match with adjoining conditions, functionally and aesthetically up to the entire satisfaction of Owner / Owner's representative /any other third party agency designated by owner and local authorities, failing which, it will be done at the risk and cost of the contractor. Obtaining No Objection Certificates for the restoration work done from the concerned authorities
11. Handing over the completed works to owner along with detailed as built drawing showing pipeline route, fittings provided in the pipelines, for their operation purposes.

Part II: GI/CS Piping Installation

1. Supply and Installation of powder coated GI pipes of ½", ¾", 1" & 2" dia. Between

transition fittings to customer's kitchen appliances including NPT threading of GI pipes, supply proper seal outs for threads to join fittings such as elbows, tees, connectors, meter regulators, meters, appliance & isolation valve etc., as per laid procedures and specification including clamping and sealing etc. The scratched powder coated GI pipe and fittings shall be painted after the testing of the GI installation.

2. Supply and Installation of GI fittings such as elbows, tees, connectors, etc., complete as per procedures and specifications including clamping and sealing etc.
3. Supply of clamps for fixing pipes, meters, valves wherever required. Providing consumable grout material, repair/restoration of walls/floors changes for the pipes including the materials required for conversions and tools and tackles etc. shall be complete as per specification.
4. Supply & Installation of Isolation Valve, Appliance Valve, Hose pipe etc., to complete the connection to the customer's appliance/stove.
5. Cleaning, flushing, pneumatic testing and commissioning to the GI pipe and fittings, meters, valves etc., as per specification and hand over the same to Owner/customer to the entire satisfaction of EIC.
6. Conversion of all types of LPG kitchen appliance to NG based appliance along with supply and installation of Steel Reinforced Flexible Rubber Hose as per IS 9573.
7. Preparation and submission of Ready for Conversion (RFC) card for each house indicating the laid GI pipe including fittings, mentioned the reasons, if connection is not provided to the customers and deviation statements on completion/commissioning of work.
8. Approval of customer on RFC card & recording Joint Meter Reading (JMR) of customer.
9. Installation of GI/CS piping, fittings along with associated valves as per PNGRB T4S standards shall be done by the contractor.
10. To Demonstrate the Customer regarding use, safety and maintenance related aspects of NG based appliances and installations.
11. Dismantling of scaffolding/temporary structures and cleaning of site & restore the site as per its original condition.
12. Restoration of walls, flooring and other damages while executing the above ground installation.
13. All risers and lateral pipe shall be clamped to the building at intervals not exceeding 1 m in place of 1.5m. Two clamps to be installed at each bend fittings or Tee fittings. Clamps should be 150mm away from each joint.

Contractor shall conduct Cu joining Qualification Test for jointers Contractor has to supply different types/sizes of approved clamps.
14. Pneumatic testing of Riser at 2 bar (g) for 2 hours and Copper testing at 80 mbar for 5 minutes shall be done.
15. Only pretested riser shall be erected using pulley. Pretesting shall be done with compressed air @ 2 bar (g) for minimum duration of 30 minutes.

All the painting work must be done after completion of testing activity only

Testing of GI Installation * Arrangement for pressurizing the installation should be shown with diagram. The testing of GI riser pipe up to regulator inlet point shall be done with isolation valve in open condition at TF side and closed condition at regulator side. PPT/Riser Testing and MMT/RFC must be certified by TPIA.

16. If tapping exceeds more than 15 meters, will be chargeable from domestic customer. It should be aware to customer at the time of either route survey or AFC drawing and shall be communicated to HOGPL/VCS.
17. All GI fittings must be Powder coated.
18. Inspection: It is responsibility of contractor to get Job Card / RCF check drawing certified at site only by TPIA. Each meter geo tagged location and time stamped photo required at the time of commissioning
19. Certified copies of RFC card in form of editable Auto-Cad drawings, PDF and hard copy to be submitted along with geo co-ordinates of Riser to be submitted. JMR to mention geo co-ordinates stamped and time stamped meter reading photo WAH ropes must be certified by PETZL and all WAH accessories must be of PETZL make, only Printable material i.e. RFC book and sticker as per owner design for each connection must be in contractor's scope in place of Client's scope as per their format.
20. The contractor shall supply the Calibrated Go-No Go Gauge and BSPT/ NPT (as decided) Gauges 1 set each of 1/2", 3/4", 1" & 2".
21. Any other activities not mentioned/covered explicitly above, but otherwise required for satisfactory completion/operation/ safety/ statutory/ maintenance of the works shall also be covered under the Scope of work and has to be completed by the Contractor within specified schedule at no extra cost to Owner.
22. All welding shall be carried out by qualified welder as per API 1104.
23. Pipe should be firmly tightened on support with U bolts or clamps, having adequate strength to hold the piping system.
24. Adequate clamps or pipe supports on the piping system shall be provided such that the safety and integrity of PNG installation is maintained.
25. Pipe support or clamps should be firmly fixed on wall or structure. A safe gap of 1" should be maintained between pipe and wall.
26. Rubber sheet shall be provided between pipe and support so to protect pipe from corrosion. PVC coated "U" clamp shall be provided to support the pipe of size 2" and higher.
27. Entire pipe work should be flushed with nitrogen / air to remove spoils, dust, dirt, welding spatter etc. Meter and regulator should be removed before flushing to avoid any potential damage. Flushing should be done from each end point.
28. After flushing, the entire pipework should be pneumatically tested, after removing meter and regulators, as per T4S for CGD networks.
29. CS piping for Industrial/Commercial connections must adhere to PNGRB T4S standards, PNGRB (Gas supplies to Industrial, Commercial Customers) Guidelines, 2020 & other relevant regulations. Contractor to refer the table below for material Specifications:

Material Standards and Specifications

Sr. No.	Item	Material Type	Specification
---------	------	---------------	---------------

1	Steel Pipe or Galvanized Pipe	Mild steel (M.S.) or Carbon Steel (C.S)	ERW GI pipes (Class C) as per IS 1239 Part 1 standard or API 5L Gr. B or ASTM A106 or ASTM A333
2	PE pipes and fittings and valves (underground)	Polyethylene	PE100 or PE80 grade, as per following standards: Pipes: IS 14885 or ISO 4437-2 or EN 1555-2 Fittings: ISO 4437-3 or EN 1555-3 Valves: ISO 4437-4 or EN 1555-4 or ASME B16.40
2	Isolation Valve	Brass/Carbon Steel (C.S)	Up to and including 2": EN 331 More than 2": API 6D
3	Galvanized Fittings	GI Fittings, Mild steel (M.S.) or Carbon Steel (C.S)	IS 1239 (Part-2); IS 1879, ASME B16.9, ASME B16.11, ASTM A234
4	Galvanized Flanges (forged)	Carbon Steel	SORF, 150#, ASME B 16.5, Material as per ASTM A 105 hot dip galvanized
5	Socket weld end fittings	CS Forged, Socket Welding fitting,	ASTM A 234 WPB, Dimensions as per ANSI B16.11, hot dip galvanized
6	PE fittings	Electrofusion Fitting	ISO 4437-3
7	Flexible Hose	Stainless Steel (S.S.) 316L	SS braided bellow pipe with polyolefin sleeve (heat shrunk)
8	Gasket	CNAF- Spiral wound or non-metallic flat	ASME B16.20 or ASME B16.21
9	Galvanized Fasteners	steel	ASTM A193 or A 194 Grade B7 or 2 H
10	Galvanizing	Hot dip Zinc coating	IS 4736
11	"U" clamp	GI Coated and PVC sleeve	1" to 4"
12	Welding Electrodes		AWS E 6010 & E6013
13	Stud bolt, Nut	Galvanized	Stud - ASTM A 193 GrB7M Nut - ASTM A 194
14	Filter	Stainless steel	50 micron mesh and forged body. Internal SS 316 and External ASTM A 106.

30. Receipt of Regulators, Meters, and Isolation Valve as a free issue items from Owner's stores, loading, transportation, unloading at project site. Proper storing, stacking, identification, providing security and insurance during and before installation and commissioning of pipelines. Obtaining the approval for optimum route and permission for work from the concerned authority and EIC.

31. Contractor shall procure all material except free issue items for installation at the outlet of PE/ GI transition fitting up to the commercial customers "Appliance

/stove / oven for satisfactory completion to the owner/owner's representative.

32. Supply and Installation of ¾" to 2.0" Welded Riser, GI/MS, from Transition Fittings for installation of Meters and Regulators. Assessment of material requirement for installation of riser & header at site, Procurement of GI Pipes (heavy duty) as per IS-1239 Part-I duly powder coated & wrought steel fittings (forged fittings) conforming to IS-1239 Part-II from any of the approved vendors of CUGL.

Scheduling, Planning of material & forwarding inspection call, Getting Dispatch clearance from CUGL/PMC, Handling, loading, transportation and unloading of these materials at contractor's store / site.

Preparation and approval of sketches, schedules, execution procedures & WPS as per technical specification. All consumables e.g. electrodes, flux etc. for welding pipes and fittings are under contractor's scope. Finalizing optimum route in consent to CUGL representative from transition fitting with isolation valve is to be installed.

Erection, Fabrication, Socket Welding, Testing & Installation of welded GI Pipes & Fittings etc., including NPT threading as per technical specification.

Supply & fixing of MS angle clamps, Ceiling clamps & dowel plugs with screws, grout material, suitable thread sealant i.e. Teflon Tape / lock tight, Supply and fixing of studs & bolts of various sizes ranging from 1/2" to 1", Jointing of transition fittings to above ground GI pipes, purging, testing and commissioning of the complete installation.

Pneumatic testing shall be carried out for entire riser length after installation of riser as per technical specification. All the safety equipments, tools and tackles required for satisfactory execution of welding/installation work are under contractor's scope.

Any other material & activities not mentioned/covered above, but otherwise required for satisfactory completion/safety of work as defined in tender has to be supplied / done by contractor within specified schedule at no extra cost to owner.

1.0 Supply and Installation of Powder Coated GI pipes of ½" dia. from welded riser tapping TEE (Isolation Valve) to customer's kitchen appliances including NPT threading of GI pipes, supply of proper seal outs for threads to join fittings such as elbows, tees, connectors, regulators, meters, appliance & isolation valves etc., as per laid procedures and specification including clamping and sealing etc. The Powder Coated GI pipe shall be finally touched up (painted) where the powder coating vanished and fitting joints after the testing of the GI installation.

1.1 Supply & Installation of MS Pipe including supply of fittings such as elbows, tees, connectors, meters, valves etc., complete as per procedures and specifications including clamping and sealing etc.

1.2 Supply & Installation of Copper pipes including supply of solder wire and flux to join fittings such as elbows, tees, connectors, meters, valves etc., complete as per procedures and

specifications including clamping and sealing etc.

- 1.3** Supply of clamps for fixing pipes, Meters wherever required, painting of pipes and fittings. Providing consumables grout material, repair/restoration of walls/floors changes for the pipes including the materials required for conversions and tools and tackles etc. shall be completed as per specification.
- 1.4** Cleaning, flushing, pneumatic testing and commissioning to the GI/MS pipe & fittings, meters, valves etc as per specification and hand over the same to Owner/Customer to the entire satisfaction of EIC/CONSULTANT.
- 1.5** To demonstrate the Customer regarding use, safety and maintenance related aspects of NG based appliances and installations.
- 1.6** Dismantling of scaffolding/temporary structures and cleaning of site & restore the site as per its original condition.
- 1.7** Restoration of walls, flooring and other damages while executing the above ground installation.
- 1.8** Preparation and submission of above ground installation card for each commercial/industrial connection, indicating the laid GI/MS pipe including fittings.
- 1.9** Any other activities not mentioned/covered explicitly above, but otherwise required for satisfactory completion/operation/safety/statutory/maintenance of the works shall also be covered under the Scope of work and has to be completed by the Contractor within specified schedule at no extra cost to Owner.
- 1.10** Following activities are also in Contractor's Scope:
- Carry out joint technical feasibility survey for requests received.
 - Attend and resolve customer complaints.

- Maintain and update the request and complaint status in CUGL's.
- Maintain new connection list.

1.11 Providing adequate manpower for carrying out laying for PNG installation for emergency cases as and when required.

2.0 MATERIAL, MANPOWER, EQUIPMENT AND MACHINERY

2.1 Material to be supplied as a free issue material

Commercial Regulators, Meters and Isolation valves shall be supplied as a free issue material to the contractor. The contractor shall not use any other material from any other source of supply other than owner's supplied material without any written approval from EIC.

2.2 Material / Equipment & machinery to be supplied by contractor

Contractor shall procure / purchase GI/MS Pipe & fittings, Wrought Steel Fittings (Forged Fittings), Brass fittings, Cu pipe & fittings, with other material which is required for satisfactory completion / safety / statutory of the works as per tender at no extra cost to Owner. The contractor shall take approval from owner / owner representative on the material to be procured by contractor before placement of order.

The Contractor shall provide labour, tools (such as Hammer Drill, Piston Drill, Pipe Cutters, Dies for threading, Pipe wrenches, spanners, conversion kits, solder torch, copper tube Cutters, tube benders, lacquering, thinner etc.) in specified numbers, all types of clamps, Plant and equipment necessary for the proper execution of the work. This will include but not limited to list of specialised tools and tackles indicated in Annexure # 1.

Special tools shall be required at site for carrying out drilling work in walls other than Brick or RCC (Ex. Granite, Marble, Wooden, Glass Cutting etc.)

The contractor has to ensure the availability of DG sets for continuous power supply. In case the power supply is availed at the site from societies, individual residents, contractor shall settle the claims raised by the electricity providers without any cost implication to OWNER. In case contractor doesn't settle the claims for using the electricity from societies/individual residents, on demand by the providers, OWNER will settle the claims and the same will be deducted from the contractor's bills. The progress of work shall not hamper due to non-availability of power supply.

The contractor has to submit the valid calibration certificate for Pressure gauges.

Contractor shall submit the manufacturer test certificate / lab test certificate for all items procured by him for approval before commencing the execution.

No hiring of equipments, tools and tackles by the contractors is allowed at the site. In case, any contractor is found not in possession of enlisted required tools and tackles, penalty will be levied as per SCC which shall be deducted from the running bill.

2.2.1 Plant and Equipment

All vehicular type machinery shall be in good working condition and shall not cause spillage of oil or grease. To avoid damage to paved surfaces, the contractor will provide pads of timber or thick rubber under the hydraulic feet or outriggers of machinery.

2.2.2 Sealant, Grout

The contractor shall be responsible to arrange the supply of any consumable sealant or ready mix grout material required for restoration of holes. The sealant/grout supplied by the contractor shall be compatible with the area to be restored / rectified. No separate payment for the supply of sealant and grout shall be made to the contractor.

2.2.3 Clamps, Rawal Plugs, Screws and Nozzles etc.

The Clamps, Brackets for meter, Rawal Plugs, Screws, Nozzles, etc. shall be approved lot wise by EIC prior to installation. Re-drilling of existing appliance (burners) nozzles is strictly not permitted. The quality of materials procured will be approved by Owner/Owner's representative or as directed by EIC.

The indicative sketch of the Brackets for Meter, Regulator Boxes and GI/Copper Pipe Clamps is enclosed with the tender. No separate payment for the supply of Meter Brackets and GI/Copper clamps shall be made to the contractor.

2.2.4 Consumables Items

- Consumables such as Electrodes, Teflon Tapes, solder wire, flux, lacquer, thinner shall be supplied by the contractor and are included in installation rates.
- These consumables shall be of reputed make companies and required grades/class.
- Pressure Gauges/ Liquid field Pressure Gauge (As per instruction by Engineer In-charge) of Range 0 – 1 Bar / as per site requirement shall be provided by contractor.
- Metallic Cage to be provided by Contractor for safety of Installations i.e. Meters and Regulators.
- Tata Blue Sheet to safeguard the installations from rain.

2.2.5 Other Materials

The contractor shall supply the following items wherever required:

- All materials required for work, NPT threading, copper pipe jointing, testing etc.
- All signs, barricades, lights and protective equipment.
- All material required for working at height (i.e., scaffolding, Ladder, Safety Belts.
- Self-Locking Safety Harness Belts like PETZL or equivalent as mentioned in safety procedure are mandatory.).
- Special consumable, all paints for painting of GI Pipes, Regulator Boxes, Consumables such as Teflon Tapes, Solder-wire, Flux, Lacquer, Thinner, Petrol, Diesel, Fuels and Oils required are to be supplied by the contractor and are included within the rates.

All minor items not expressly mentioned in the contract but which are necessary for the satisfactory completion and performance of the work under this contract.

6.0 CONDITIONS FOR ISSUE OF MATERIALS

Whenever any material is issued by Owner, following conditions for issue of material in addition to other conditions specified in the contract shall be applicable.

1. Necessary indents will have to be raised by the Contractor as per procedure laid down by the Engineer-in-charge from time to time, when he requires the above material for incorporation in permanent works.
2. Materials will be issued only for permanent works and not for temporary works, enabling works etc. unless specifically approved by the Engineer-in-charge and the same shall not be taken into account for the purpose of materials reconciliation.
3. The contractor shall bear all other cost including lifting, carting from issue points to work site/ contractor's store, custody and handling etc. and return of surplus/ serviceable scrap materials to Owner's storage points to be designated by the Engineer in-charge etc. No separate payment for such expenditure will be made.
4. No material shall be allowed to be taken outside the plant without a gate pass.
5. The contractor shall be responsible for proper storage, preservation and watch & ward of the materials.

7.0 RECONCILIATION OF OWNER SUPPLIED MATERIALS

Every month, the contractor shall submit an account for all materials issued by Owner in the Performa prescribed by the Engineer-in-charge. On completion of the work the contractor shall submit "Material Appropriation Statement" for all materials issued by the Owner in the Performa prescribed by the Engineer-in-charge.

Waste materials like part lengths of pipes and other partly used items are the property of Client and must be returned to the store with the appreciate documentation so that they can be considered as part of the material reconciliation.

Item	Scrap	Unaccountable
Gas Meters	0%	0%
Regulators	0%	0%
PE Pipes	2% (Less than 2 Mtr.)	2%
GI&CU Pipes (UPTO size of ¾" Diameter)	1% (Less than 0.5 meter)	1%
Isolation & Appliance valves (UPTO size of ¾" Diameter)	0%	0%

* In case supplied by Owner

GI Pipes & Isolation Valve of 1" & above size shall be in the scope of contractor.

Unaccountable wastage/ scrap shall be at actual as per site assessment subject to maximum as stated above.

The percentage allowance shall be accounted on the basis of final measurement book.

1. All unused, scrap materials and salvageable materials shall be the property of the Owner and shall be returned by the Contractor category-wise at his cost to the Owner's designated store yard(s). In case the Contractor fails to do so/ or exceeds the limits of allowances specified above for scrap/ serviceable materials, then recovery for such quantities not returned as well as returned in excess of permitted limit by the Contractor will be done at the penal rate i.e. 125% of landed cost at the time of final bill/ closing of contract by Engineer-in-charge shall be effected from the Contractor's bill(s) or from any other dues of the Contractor to the Owner. Contractor shall be responsible for the adjustment/ weighment/ measurement of the surplus materials to be returned to the store. Contractor shall also be responsible for suitable segregation of returned materials into separate stacks of serviceable and scrap materials.
2. Scratched MDPE pipeline acceptable allowance should not more than 10 percent of the O.D.
3. Wherever certain material is covered under Contractor's scope of supply whether part or in full for any item of work covered under SOR, no allowance towards wastage / scrap etc. shall be accounted for during execution stage.
4. In every RA bill, the contractor shall submit an account for all materials issued by Owner in the proforma prescribed by the Engineer-in-charge. On completion of the work the contractor shall submit "Material Appropriation Statement" for all materials issued by the Owner in the proforma prescribed by the Engineer-incharge.
5. In case of any faulty Domestic/Commercial Diaphragm Meters and Regulators found within warranty period., it shall be returned to HOGPL store with proper reasons of fault/condition with AIC/EIC approval.

**HEALTH, SAFETY ENVIRONMENT [HSE]
SPECIFICATIONS**

HEALTH, SAFETY AND ENVIRONMENT [HSE] SPECIFICATIONS

1.0 SCOPE

These specifications establish the 'Health, Safety and Environment [HSE] Management' requirement to be complied with by the Contractors during executing their Job. Requirements stipulated in these specifications shall supplement the requirements of 'HSE Management' given in relevant act(s) / legislation(s).

2.0 REQUIREMENTS OF 'HEALTH, SAFETY AND ENVIRONMENT [HSE] MANAGEMENT SYSTEM' TO BE COMPLIED BY BIDDERS

- 2.1 Preferably, the Contractor should have a documented 'HSE Policy' to cover commitment of their organization to ensure health, safety and environment aspects in their line of operations or they must follow the 'HSE policy' of HOGPL for safe execution of work.
- 2.2 The Contractor shall ensure that the HOGPL's 'Health, Safety and Environment [HSE]' requirements are clearly understood and faithfully implemented at all level, at sites.
- 2.3 Contractor shall promote & develop consciousness for Health, Safety & Environment among all personnel working for the Contractor. Regular work-site meetings (Tool box talk) shall be arranged as 'HSE' activities to cover hazards involved in various operations during executing their jobs, location of First Aid Box, trained personnel to give First Aid, Assembly Points, and fire protection measures such as water and fire extinguishers etc.
- 2.4 Non-conformance of 'HSE' policy and directives as per HOGPL by Contractor [including their sub-Contractors] as brought out during review/audit by HOGPL / external agency authorized by HOGPL, shall be complied by Contractor and its report to be submitted to HOGPL.
- 2.5 Contractor shall adhere consistently to all provisions of 'HSE' requirements. In case of non-compliance of continuous failure in implementation of any of the 'HSE' provisions, HOGPL may impose penalty and subsequent stoppage of work for non-compliance. The decision of imposing monetary penalty & work-stoppage shall be taken by EIC with consultation with Safety Officer of HOGPL.
- 2.6 All fatal accidents and other personnel accidents shall be investigated for root cause by HOGPL and Contractor shall extend all necessary help and cooperation in this regard. Recommend corrective and preventive actions of findings will be communicated to Contractor for taking suitable actions should be taken by the Contractors to avoid recurrence of such incidences.

- 2.7 Contractor shall ensure that all their staffs and workers, including their sub-Contractor(s), shall wear 'Personal Protective Equipments [PPEs]' such as safety helmets, safety shoes, safety belts, dust mask, ear plug, protective goggles, gloves, etc., as per job requirements. All these gadgets shall conform to relevant IS specifications or equivalent.
- 2.8 Contractor shall assign competent & qualified personnel for carrying out various tasks/jobs as per requirement.
- 2.9 All equipments should be tested and certified for its capacity before use.

- 2.10 Contractor shall ensure storage and utilization methodology of materials that are not detrimental to the environment. Where required, Contractor shall ensure that only the environment-friendly materials are used.
- 2.11 All persons deployed at site shall be knowledgeable of and comply with the environmental laws, rules and regulations relating to the hazardous material substances and waste. Contractor shall not dump release or otherwise discharge or dispose-off any such materials without the express authorization of EIC of HOGPL.
- 2.12 Contractor should obtain all work permits before start of activities [as applicable] like hot work, cold work, confined space, electrical isolation, work at heights and its use & implement all precautions mentioned therein.
- 2.13 Contractor should display at site office and work locations caution boards, provide posters, banners for safe working to promote safety consciousness, etc.
- 2.14 Contractor should properly barricade the facility where work is in progress for safe working and reclaim the work zone after completion of work to promote safety consciousness.

3.0 RELEVANT CODES FOR 'PERSONAL PROTECTION EQUIPMENTS'

IS: 2925 - 1984	Industrial Safety Helmets
IS: 47701 - 1968	Rubber Gloves for Electrical Purpose
IS: 6994 - 1973 [Part-I]	Industrial Safety Gloves [Leather & Cotton Gloves]
IS: 1989 - 1986 [Part-II]	Leather Safety Boots & Shoes
IS: 5557 - 1969	Industrial & Safety Rubber Knee Boots
IS: 6519 - 1971	Code of Practice for Selections, Care & Repair of Safety Footwear
IS: 11226 - 1985	Leather Safety Footwear Having Direct Molding Sole
IS: 5983 - 1978	Eye Protectors
IS: 9167 - 1979	Ear Protectors
IS: 3521 - 1983	Industrial Safety Belts & Harnesses

Guidelines for imposition of punitive fines

- 4.0 Punitive fines on contractors are imposed for violation of safety rules & regulations during execution of jobs. Objective of punitive fines is to work as deterrent for contractors in violation of safety rules & regulation and to improve safety atmosphere in general at all site.

Proposed guidelines for imposition are described below:

- 4.1 In case of violation of safety rules & regulations by contractor, punitive fines will be imposed on contractor. Amount as fine will be decided as per severity of violation of safety. However, minimum fine would be Rs. 5,000/- and in multiple of Rs.5,000/-, thereafter for every instant.

**STANDARD SPECIFICATION FOR LAYING OF
POLYETHYLENE MAIN PIPELINES AND SERVICE
PIPELINE FOR INDUSTRIAL & COMMERCIAL PNG
CONNECTIONS**

CONTENTS

1.0	GENERAL INFORMATION	3
2.0	DEFINITIONS	3
3.0	SCOPE OF WORK	3
4.0	MATERIAL, MANPOWER, EQUIPMENT AND MACHINERY.....	6
5.0	PROGRESS OF WORK	8
6.0	APPROVALS & PERMISSIONS FOR PIPELINE LAYING	8
7.0	REFERENCE SPECIFICATION, CODES AND STANDARD	9
8.0	QUALITY OF WORK.....	9
9.0	SAFETY	9
10.0	ROUTE SURVEY.....	10
11.0	ORGANISATION STRUCTURE	10
12.0	STRUCTURES, SERVICES AND OTHER PROPERTY	11
13.0	TRENCHING	12
14.0	LAYING.....	15
15.0	JOINTING OF POLYETHYLENE PIPE	18
16.0	BACKFILLING	18
17.0	MOLING.....	20
18.0	HORIZONTAL DIRECTIONAL DRILLING (HDD).....	20
19.0	CASING PIPE	21
20.0	RESTORATION	21
21.0	TESTING.....	22
22.0	PURGING.....	23
24.0	CONSTRUCTION OF TRENCHES AND OTHER SCOPE OF WORK IN BUILDER SEGMENT	24
25.0	ROUTE MARKERS	24
26.0	GUIDELINES:	25
27.0	ASSISTANCE IN COMMISSIONING.....	25
28.0	STANDARD OF WORK.....	25
29.0	RECORDING (AS-BUILT DRAWINGS)	25
30.0	CIVIL WORKS	26
32.0	TESTING OF CONSTRUCTION MATERIALS.....	33
33.0	INSPECTION BY THIRD PARTY INSPECTION (TPI) AGENCIES NOMINATED BY LAND OWNING AGENCIES	34

1.0 GENERAL INFORMATION

HPOIL Gas Private limited (HOGPL) consortium of HPCL & OIL has received the authorization from PNGRB vide letter PNGRB vide letter PNGRB/CGD/BID/8/2018/GA/Ambala-Kurukshetra District dated 22/02/2018 and PNGRB/CGD/BID/8/2017/BEC/GA-Kolhapur dated 06/03/2018, to Lay, Build and Operate City Gas Distribution networks in Ambala-Kurukshetra and Kolhapur District. HOGPL (hereinafter referred as Owner), is supplying Piped Natural Gas (PNG) to domestic, commercial, and Industrial consumers and Compressed Natural Gas (CNG) to automobiles in Ambala-Kurukshetra and Kolhapur District.

VCS Quality Services Pvt. Ltd. (VCS has been appointed as Project Management Consultant for providing consultancy services for CGD Expansion Project for PNG in Ambala-Kurukshetra & Kolhapur (hereinafter referred as Consultant), by HOGPL.

2.0 DEFINITIONS

OWNER	HPOIL GAS PRIVATE LIMITED (HOGPL)
PMC	VCS QUALITY SERVICES PVT. LTD. (VCSQSPL)
SS	STANDARD SPECIFICATION
TPIA	THIRD PARTY INSPECTION AGENCY (TO BE APPOINTED BY HOGPL)
EIC	ENGINEER- IN - CHARGE

3.0 SCOPE OF WORK

The main scope of this Specification comprises of laying of underground Medium Density Polyethylene (MDPE) main pipelines and service pipeline. The scope covers all the activities associated with the purchasing (specified items only), laying, testing and commissioning of MDPE main pipelines and service pipelines in new & existing gas charged areas of sizes ranging from 20mm up to 32 mm OD, which includes PE/GI transition fitting above ground level and above ground laying and commissioning of powder coated GI pipeline, meter & regulator etc. including burner conversion and commissioning.

Generally, the following shall constitute the contractor's scope of work but not limited to:

- 3.1 Plan and prepare a schedule for execution and work implementation as per QA/QC plans to be issued by Owner/Owner's representative. Contractor has to submit the Construction/Execution procedures before commencement of work to Owner/Owner's representative for approval.
- 3.2 Prior to start of construction activity, contractor shall carry out the route survey and prepare the approval for construction (AFC) drawings marked for proposed gas pipe line laying and submit to HOGPL/PMC for approval.
- 3.3 Co-ordination /Liaison from respective land-owning agencies such as Municipal Corporation, CPWD, ADA/LDA, Nagar Nigam, PWD-NH, NHAI, Indian Railway, Forest & Environment Department, Irrigation department and other land owing agencies for road cutting for laying of the pipelines, Liaison with the concerned authorities during execution of the job, obtaining NOC from concerned authorities once the work is completed. Getting back/refund of bank guarantee / security deposits made to the agencies for laying of the pipelines.
- 3.4 Obtaining clearances and coordination with concerned RWA of the allotted area

for internal network laying and obtaining NOC from RWA after completion of work.

- 3.5 Transportation of Free Issue Material from HOGPL's stores to contractor stores, proper storing, and stacking, providing security, transit insurance cover during storage, laying, commissioning and handling over pipelines to owner.
- 3.6 Obtaining the approval for optimum route and ROU from the concerned authority.
- 3.7 Intimation to the parallel utilities (Electrical/Communication/Water) owners and making trial pits to determine the underground utilities/services such as existing pipelines, cables (electrical/communication), conduits, U/G drainage, Sewers, tunnels, subways foundations etc. for deciding optimum feasible route and depths for laying the pipelines based on the route plans indicated by owner.
- 3.8 Wherever required the grass/turfing, pavement, linings, drains, roads and other such 'pucca' area shall be locally removed to facilitate trenching and pipe laying works. The same is to be reinstated as original.
- 3.9 Installation of safety/warning signs and barricading of the entire route to be trenched. Pits to be similarly barricaded along with warning signs and caution boards.
- 3.10 To make trenches with stable slopes but restricting minimum disturbance to above ground/underground services/installation as per specifications and approved route plans keeping the trenches free from water and soil till placement of pipes.
- 3.11 Uncoiling/stringing the MDPE pipes of required sizes (i.e. 32 & 20 mm) pipes into trenches as per approved procedure.
- 3.12 Joining the pipe ends with fittings of valves by approved automated electro-fusion techniques only as per tender specification.
- 3.13 Installation of pipe fittings like elbow, tees, reducers, couplers, tapping saddles, transition fittings, valves etc as per specification & satisfaction of the EIC.
- 3.14 Laying pipelines by any methodology including trenchless technology methods with or without casing pipes (HDPE pipes) as per specifications and as directed by EIC.
- 3.15 Fabrication, supply and inspection of approved quality GI sleeve and half concrete sleeves and other materials, fittings to be supplied by the contractors as per the provisions of tender.
- 3.16 Back filling and compaction by jumping jack compactor wherever required, using approved 'good' soil or using excavated earth or borrow earth as per requirement and specifications and replacement of the tiles, slabs removed during the excavation. Cleaning all unserviceable materials, debris, excess earth trenches etc. to designated disposal area.
- 3.17 Carrying out pneumatic testing and purging as per specifications and approved procedures, providing all tools & tackles, instruments, manpower and other related accessories for carrying out the testing of pipes.
- 3.18 Supply, fabrication & installation of RCC route marker, Pole marker with foundations, Plate markers, valve chamber etc. as per the directions of the EIC/Owner's representative.
- 3.19 Nitrogen purging (including supply), commissioning and gas charging in the tested PE line shall be done as per the approved procedure.

- 3.20 Restoration of existing ground features such as grass/turfing, paving, roads, drains, concrete, floral beds, fencing, tiles, marbles, flooring masonry etc. to original condition and to match with adjoining conditions, functionally and aesthetically up to the entire satisfaction of Owner / Owner's representative /any other third-party agency designated by owner and local authorities, failing which, it will be done at the risk and cost of the contractor. Obtaining No Objection Certificates for the restoration work done from the concerned authorities.
- 3.21 Returning surplus material to Owner stores after obtaining clearance from TPIA/Consultant/ Owner, reconciliation of free issue material/consumables.
- 3.22 Handing over the completed works to owner for their operation/use purposes.
- 3.23 Rectification of defects arising due to poor workmanship during defect liability period of pipelines/installations handed over to Owner.
- 3.24 Preparation and submission of all documents like Pit wise As graph, As-built drawings, details of crossings, utility graphs, PE cards for service line and deviation statements on completion/commissioning of work by way of drawing, sketches and tables in soft & hard copy.
- 3.25 Providing adequate manpower for carrying out laying for PNG installation for emergency cases as and when required. Providing adequate manpower for material for carrying out laying for PNG installation for emergency cases as and when required, as per instruction of EIC.
- 3.26 Following activities are also in contractor's scope:
- Receive Customer's complaints logged during MDPE Laying.
 - Attend and Carry out joint technical feasibility survey for requests and resolve the complaint.
 - Maintain and update the complaint status.
- 3.27 Supply and installation of above ground GI pipeline, fittings, Valves and other materials except free issue material (Meter and regulator) for last mile connectivity of some of domestic, commercial and industrial customers. Technical Specification of GI pipe and fittings are attached.
- 3.28 Carrying out Ground penetrating Radar (GPR) survey from recognized agencies to determine the underground utilities/services such as existing pipelines, cables electrical/communication), conduits, U/G drainage, Sewers, tunnels, subways foundations etc. for deciding optimum feasible route and depths for laying the pipelines based on the route plans.
- 3.29 Repair and Maintenance of MDPE pipe line as excavation, leakage arrest, jointing and restoration of any size including supply and installation of all fittings required in case of third-party damage after commissioning. MDPE Pipe required shall be issued by Owner as free issue material.
- 3.30 Any other activities not mentioned/covered explicitly above, but otherwise required for satisfactory completion/operation/ safety/ statutory/ maintenance of the works shall also be covered under the Scope of work and has to be completed by the Contractor within specified schedule at no extra cost to Owner.

This technical specification defines the basic guidelines to develop an acceptable design and suitable construction methodology for carrying out different activities listed out in the schedule of rates of this tender.

Compliance with this specification and/ or approval of any of the Contractor's

documents shall in no case relieve the Contractor of his contractual obligations

Any other activities not mentioned/covered explicitly above, but otherwise required for satisfactory completion/operation/ safety/ statutory/ maintenance of the works shall also be covered under the Scope of work and has to be completed by the Contractor within specified schedule at no extra cost to Owner.

4.0 MATERIAL, MANPOWER, EQUIPMENT AND MACHINERY

Material to be supplied by Owner as Free Issue.

Unless otherwise specified, owner will only supply MDPE pipe and all materials & fittings other than mentioned above shall be supplied by contractor as per technical specification to complete the laying of service pipeline.

The free issue material shall not be procured from any other source by contractor. Material reconciliation statement of free issue material duly certified by Owner and PMC shall be submitted to HOGPL on monthly basis.

Material to be supplied by the contractor:

The supply of items as indicated in SOR but not limited to shall be strictly as per relevant technical specifications enclosed with the Tender and as per guidelines of various clauses of SCC and SOR.

All materials shall be handled safely and stored in a permanent, covered, lockable store/ ware house preferably near site in such a manner as to prevent any damage to the materials from scratching, gouging, indentation, excessive heat or by contact with any sharp objects or chemicals. The MDPE pipes and fittings shall be stored in covered storage to protect material from sunshine, rain etc. Pipe should be stacked with clearance from ground level.

4.1 Backfilling Material

The contractor shall be responsible to arrange the supply of approved coarse sand (size 0.6 - 2 mm as per IS 383) free from any impurities like clay, mica, and soft flaky pieces, as per the instructions of EIC /Owner's representative. For supply of sand in trench for rocky terrain, no separate charges are payable and is included in rates. Also supply of sand in valve chambers, Normal surface & built up surface, if required, as per the instructions of EIC is not separately payable.

In case specified trench, depths are not achieved or if directed by Engineer-In Charge Contractor has to provide concrete casing pipes/ slabs, extra rate of PCC may be payable with prior approval of EIC/PMC.

Other materials: The contractor shall supply the following items wherever required:

- All materials required for framework, trench support and temporary trench Crossings.
- All sign boards, barricades, tin sheets, lighting arrangement and protective equipment.
- All minor items not mentioned in the specification but necessary for the satisfactory completion and performance of the work.
- Material required for installation of valve chambers.
- GI, Half Round Concrete Sleeves.

- Permanent markers (Refer enclosed drawing no 14588-10-03-28, 29, 30, 31)
- Warning Mat

4.2 Manpower

The contractor shall provide the skilled labour, tools, material and equipment necessary for the proper execution of the work.

4.3 Equipment, Machinery & Tools

This will include but is not limited to the list of specialized items included in Annexure# I

All vehicular type machinery shall be in good working order and shall not cause spillage of oil or grease. To avoid damage to paved surfaces, the Contractor will provide pads of timber or thick rubber under the hydraulic feet or outriggers of machinery.

Contractor must also have to arrange his own equipment for restoration work like water tanker and jumping jack compactor for compaction of backfilled trenches and roller and other required equipment/ machinery for asphaltting/ road works.

In case there is non-availability of approved equipment's, tools and tackles during the work at site, suitable penalties, as per special terms and conditions of the contract, will be levied and deducted from the running bills.

4.4 Acquisition, Receipt & Storage Of Materials

The Contractor shall collect all materials from HOGPL during stores working hours following all documentation procedures laid down and as directed by the EIC. The Contractor shall carry pipe in such a manner as to preclude damage during transportation and handling. PE pipes supplied in straight lengths may be carried in straight pipe racks.

The contractor shall at the time of receipt of material physically examine all materials and notify the EIC immediately of any damage or defect noticed by the contractor. Any damage not so recorded will be deemed not to have existed at the time of receipt of material by the contractor and the cost of repair or replacement or rectification shall be borne by the contractor. Any material once issued from HOGPL store, if found in nonworking condition at site shall be brought to the notice of EIC with PO reference in written within 15 days and after subsequent approval shall return defective material in HOGPL stores within 30 days.

If delay is more than 30 days and material is under warranty, the material will be accepted with a penalty, else the material will not be reconciled and amount of the same will be deducted from bills. Penalty shall be levied as per SCC. The contractor shall ensure that no defective material shall be returned to store at the time of closure of contract. The format for defective materials returning to stores will be made available by EIC.

The contractor shall maintain locked store preferably near at site so that all the materials are stored in such a manner so as to prevent any damage to the materials from scratching, gouging, indentation, excessive heat or by contact with any sharp objects or chemicals. The PE pipes and fittings shall be stored in covered storage to protect material from sunshine, rain, water logging etc. The contractor shall make adequate security arrangements for the stacked material & any loss to the material on account of theft on improper storage is attributable to the contractor.

The Contractor shall maintain log book at their respective stores stating issue and availability of free issue material at a given day. Further, it is mandatory that the contractor is required to undertake and submit inventory details of free issue and purchased materials on monthly basis to Owner/ Owner's representative as per the approved format of the owner. The inventory details shall be in correlation with the Daily progress chart and material reconciliation sheet.

In case of non-submission of material reconciliation on first week of every month, applicable penalties shall be levied as per SCC from the running bills. In case if shortage in free issue material is observed at the time of quarterly physical verification by HOGPL, equivalent value of material found short shall be withheld from running bills, same shall be released after settlement of free issue material.

5.0 PROGRESS OF WORK

The contractor shall proceed with the work under the contract with due expedition and without delay. The EIC may direct in what order and at what time, the various stages or parts of the work under the contract shall be performed. Contractor has to regularly submit daily progress reports, weekly progress reports, graphs with utilities, testing reports, material consumption and inventory reports, deviation statements, completion schedule etc.

6.0 APPROVALS & PERMISSIONS FOR PIPELINE LAYING

Contractor has to obtain permissions from statutory bodies for laying of pipelines. Statutory bodies in this case are MCD, NDMC, PWD, NHAI, CPWD, AAI, Indian railways, DDA, GNN, GDA, Noida, G. Noida and any other government agencies who maintain the public lands and accord permissions for laying of the utilities. The contractor shall obtain demand note (road restoration charges) from these statutory bodies. Contractor shall ensure that the road restoration charges are to the minimum against the work to be carried out. HOGPL may return back the demand note, if the charges are not found reasonable and contractor shall not be liable for any liaison charges against the same.

However, HOGPL will pay the road restoration / Departmental charges / security deposit I Bank guarantees for getting the clearances from statutory bodies. It is the contractor's responsibility to inform and co-ordinate the concerned local authorities and also other utility agencies before and after the commencement of work at site. To ensure smooth execution of the work on a day-do-day basis, the contractor has to liaison with respective authorities. The contractor shall plan and ensure that work taken up under a single permission shall be completed within the stipulated time period and revalidation process is avoided. No separate liaison charges are liable to IGL for revalidation cases.

It is the responsibility of the contractor to obtain "No Objection Certificate" (NOC) from land owing agencies/Statutory bodies after completion of the restoration to their satisfaction and getting released the security deposit I bank guarantees submitted by IGL for obtaining permissions on production of documentary evidence. Separate payment in running meters will be made on account of approvals/permissions as per the SOR it based on total applied length except for GENERAL SOR where the rates are inclusive of liaison rates. In case of any deviation/change in the route/additional laying, HOGPL shall pay the additional Road Restoration Charges only after receiving of revised estimate and further to written confirmation from the concerned Owner site in-charge.

On behalf of the Owner, contractor shall prepare in advance and submit the proposed route plan complete in all respect and well ahead of time so that the actual construction work is not delayed because of approval/inspection/permission by concerned authorities. Further, the contractor shall also coordinate with the relevant authorities for necessary approvals of these proposed pipeline route drawings/certificates. The inspection of work by statutory authorities shall be the responsibility of the contractor without any extra cost to HOGPL.

In case contractor delays laying of pipeline work under a single permission, the work or part of work may be offloaded to some other contractor on his risk and cost. Any change / addition required to made to meet the requirements of the statutory authorities shall be carried out by the contractor without any extra cost to HOGPL. The inspection and acceptance of the work by statutory authorities shall however, not absolve the contract from any of his responsibilities under this contract.

7.0 REFERENCE SPECIFICATION, CODES AND STANDARD

The contractor shall carry out the work in accordance with the requirement of latest relevant applicable standards, this specification, Owner's Engineering Standards; relevant Oil Indian Safety Directorate (OISD) norms, PNGRB Regulations, ASME B31.8-Gas Transmission and Distribution Piping Systems; Australian Standard 3723-Installation and Maintenance of Plastics Pipe Systems for Gas; and the American Gas Association Document - Purging Principles and Practice. ISO-4437/JS: 14885 for underground polyethylene pipes and OWNER's approved procedures.

Should the contractor find any discrepancy, ambiguity or conflict in or between any of the standards and the contract documents, then this should be promptly referred to the Engineer-In-Charge (EIC) for his decision, which shall be considered binding on the contractor.

8.0 QUALITY OF WORK

All works carried out under this contract shall confirm to applicable standards, codes of practice, construction procedures and other technical requirements as defined in the technical specifications.

The manpower deployed on the respective activities shall be adequately trained & shall have necessary skills to execute / supervise the work. However, the assessment on the qualification of the personnel shall be at the discretion of EIC.

Fusion operators and other skilled personnel shall be approved by Owner/ Owner's representative and identification cards duly signed by EIC shall be issued to them. Only those personnel who are approved by shall be allowed to execute the critical activities like electro fusion jointing of MDPE pipes & fittings. HOGPL may provide training and certification on chargeable basis where the cost shall be borne by contractor.

9.0 SAFETY

The Contractor shall conform to the safety requirements outlined elsewhere in the tender document. In addition, the Contractor shall observe safe working practices in the storage and handling of cleaning fluids, flammable fluids, etc., and ensure smoking or naked flames are not permitted in the vicinity when these materials are being used.

Trench walls shall be battered with sufficient slope in order to minimize a trench collapse. Where there is a danger of an earth slide or collapse, the trench shall remain open for the minimum time possible with proper barricading. The Contractor is to ensure that no person enters a trench, which is of a depth of 1.5 meters or greater, unless the trench has adequate shoring or the sides are battered to such an extent as to prevent a trench collapse.

The Contractor shall also protect all work sites with warning signs, barricades and night lighting. The Contractor shall inspect all fenced excavations daily, and maintain them in good order.

The trenches/ pits shall not be kept open in night times. However, in case the same is essential the same shall be properly barricaded with proper lighting arrangements & manned.

The Contractor shall provide PPE's like helmets, safety shoes, etc. to the labour which are necessary for safe working practice.

Any accident causing injury to any person or damage to property or equipment shall be reported to the EIC and the cost of repair / replacement of the damage equipment shall be borne by the contractor. Where the EIC determines that the work is being performed

by the Contractor in an unsafe manner, he may suspend the Work until corrective action is taken by the Contractor.

PPE, Continuous Barricades and caution tapes along the trenches as per approved drawing in tender, Use of Safety Boots, Hand gloves, Reflective jackets, Hard hats(helmets), Safety shoes, eye and ear safety equipment, Fire extinguishers and as per the detailed scope of work in tender specifications. Contractor shall be paid as per SOR measurement sheet of laying should also include length of barricading. Refer drawing number 14588-10-03-26, 32. For further details Refer "Special Terms and conditions of Contract" & SOR.

10.0 ROUTE SURVEY

Planning, detailing the size, route survey drawings, identification of underground utilities, foreign pipelines, crossings, and location of valve chamber, FRS, DRS, MRS as well as service line location is in scope of contractor.

10.1 Mainlines

The final alignment of mainlines will be worked out at site in consultations with the Owner/Owner's representatives after route survey and trial pits, at contractor cost. Any change in routing from the issued drawings due to site constraint will be notified to EIC & his specific written approval shall be obtained before carrying out the job.

10.2 Service lines

Consultant/Third Party Inspection Agency and the contractor will conduct a joint survey at each probable premise/ housing colony/pockets/area to be supplied with gas. The survey record will note customer's detailed potential gas supply points, proposed regulator positions and estimates of material quantities. The contractor's representatives will make sketch of the agreed pipe routes.

The contractor will be responsible for contacting the customer and making the necessary arrangements for access and appointments to carry out the work. Contractor shall maintain job card and complaint books at site. Owner will not be responsible for time lost due to failed appointments or disputes with customers.

11.0 ORGANISATION STRUCTURE

Contractor shall designate Project Manager / Coordinator who will be responsible to interact with EIC/Consultant/TPIA and authorized to attend review meetings, receive material, authorized to sign documents, claims and receive payments etc. Contractor shall employ a Project Manager Coordinator on company roll. Project manager / coordinator & Site Engineers on company roll. The Project Manager/ Coordinator must have qualification of BE Mech. /Diploma in Mech. Engg. with min. 2-5 years & Site Engineer must have minimum Diploma in Mechanical Engineering with 3 years of work experience in gas pipe line job. He shall be single point of contact for all the works and must represent company in the review meetings.

All construction work will be carried out as per direction of EIC, and this will be the primary point of contact between the contractor and Owner on site. All work will be issued and sanctioned through the EIC and site control exercised by Site Engineers. The contractor shall ensure that technical quality standards are maintained, that construction is carried out cost effectively and that a good customer and public image is maintained for Owner.

The contractor will deploy his own supervisors as directed by site engineers/EIC. These personnel will be reporting to the Site Engineer for monitoring construction standards and for ensuring that all technical requirements are met for the job being carried out. The contractor's supervisor(s) will have day-to-day liaison with the Site Engineer, and will

provide the Site Engineer with technical reports and audits, and other management information as is required on work progress and construction quality standards.

The contractor's supervisor shall have mobile telephones to ensure that they can be contacted at all times. The contractor will also nominate one person who can be contacted if necessary, in odd hours, for the duration of the works. The contractor's supervisor will have access to transport at all times to allow them to visit sites and attend meetings with Owner. Supervisor shall attend to normal day-to-day issue of work instructions, communication between Owner and the contractor's supervisor and the Site Engineer.

Contractor shall maintain a Customer Care Centre, Project Site Office, and Material Store in their allotted site with following facilities:

- Telephone, Mobile Phones, Fax machines, Printers/Scanning/Xerox machines, Computers with internet facility.
- One Nos. -Four-wheeler with driver, he shall be well equipped with tools and tackles for attending any emergency complaints and ongoing execution work.
- On award of the contract, the contractor shall establish and submit documentary evidence for above, which will be verified by the owner before award of the work order.

12.0 STRUCTURES, SERVICES AND OTHER PROPERTY

12.1 Location of Underground Utilities

The contractor shall locate all buried utility pipes, underground cables, water mains and other obstructions intersecting or adjacent to the Works, and shall make available the necessary labour to expose and record the depth of cover over all obstructions in advance of excavation. This shall be done far enough in advance of excavation to facilitate gradual change in grade or position found necessary to clear any obstructions.

In addition, the contractor shall excavate trial pits as necessary to determine the pipe route. The number of trial pits will be agreed with the Site Engineer in advance of any excavation. In any event, trial pits shall be made at intervals of a maximum of 30 meters. Restoration of the abandoned trial pits and trenches shall be the contractor's responsibility. No payments shall be made for such type of jobs. The trial pits shall be excavated to minimum depth of 1.5 meters so as to locate any utilities present in the trench.

It is contractor's responsibility to interact with other utility agencies regarding their existing utilities and finalize the route along with these agencies and Owner/ Owner's representative.

There will be no additional payments in respect of abandoned trenches incurred because of insufficient or inadequate trial pits, or any associated loss of time or delays.

Contractor must ensure that before starting the execution of laying of pipeline, the intimation/information must cascade to all utilities agencies seeking the information about the existing utility in the proposed route.

12.2 Protection of Structures and Utilities

The Contractor shall at his own cost support and protect all buildings, walls, fences or other structures and all utilities e.g. Electrical cables, Telephone Cables, Water pipelines, Sewer pipelines etc., and property which may be damaged as a result of the execution of the works. He shall also comply with the requirements in the specification relating to protective measures applicable to particular operations or kind of work. Special care shall be taken while laying of pipelines near the trees.

12.3 Interference with Traffic, Street Drainage and General Public

The Work shall be executed in such a manner so as to cause a minimum inconvenience to persons using public or private roads, lanes, thoroughfares, walkways, rights-of use or passages through which the Works are to be executed. The trench shall be back filled; compacted, leveled and extra soil shall be removed immediately after laying of pipeline to avoid public inconvenience. Closure of roads, etc., shall not be permitted without the approval of the EIC.

The Contractor shall comply with all local Authorities requirements to traffic and keep roads open to traffic and maintain access to and within any private property.

Wherever the pipe route crosses driveways, access tracks or entrances to private properties the Contractor shall give the owner, occupier or relevant authority at least 24 hours prior notice of intended commencement of excavation and shall be restricted to pass through.

The Contractor shall not use a private driveway, access track or entrance without the prior approval of the EIC in any circumstance.

The Contractor shall provide suitable access wherever necessary in the form of temporary bridges, culverts, flumes, etc., of a size and type approved by the EIC.

The Contractor shall comply with all relevant road Laws. Where limits and/or speed limits have been placed in the vicinity of the Works, the Contractor shall provide for the necessary movement of plant and equipment in accordance with the requirements of the relevant authority.

The Contractor shall not obstruct any drainage pipes or channels in any road but shall divert them wherever necessary and use all proper measures to provide for the free passage of water.

The Contractor shall handover the completed works after proper cleaning of the site.

The contractor shall conduct his operation at all times, with a view to minimize as far as practicable noise and other objectionable nuisances (e.g. oil leakage, spillage, debris etc.)

13.0 TRENCHING

The schematic drawing with the details of trench is enclosed in the tender as per drawing No. 14588-10-03-27

The Contractor shall perform the excavation works so as to enable the pipe to be laid in conformity with the levels, depths, slopes, curves, dimensions and instructions shown in the Drawings, Specifications or as otherwise directed by the EIC.

Contractor shall excavate and maintain the pipeline trench on staked center line as per approved drawing taking into account the horizontal curves of the pipelines.

While trenching, care shall be taken to ensure that all underground structures and utilities are disturbed to the minimum. Suitable crossing shall be provided and maintained over the ROU wherever necessary to permit general public, property owners or his tenants to cross or move stock or equipment from side of the trench or another.

Trenching shall be made with sufficient slopes on sides in order to minimize collapsing of the trench. On slopes wherever there is danger of landslides, the pipeline trench shall be maintained open only for the time strictly necessary. Owner may require excavation by hand, local route and detouring and limiting the period of executing of the works. Before trench cuts through water table, proper drainage shall be ensured, both near the ditch and ROU in order to guarantee the soil stability.

The Contractor shall ensure that trench bottom is maintained in the square form as far as possible, with equipment, so as to avoid/minimize the hand grading at the bottom of the trench. The Contractor shall do all such handwork in the trench as required to free the bottom of trench from loose rock, pebbles and to trim protruding roots the bottom and sidewalls of the trench.

13.1 Depth of Trench

The minimum depth of cover shall be measured from top of pipe to the top of undisturbed surface of the soil or top of the graded working strip or top of road or top of rail, whichever is lower.

In case of crossing of water bodies, the minimum depth shall be measured from the top of the pipe to the bottom of Scour level.

The depth of the trench will be such as to provide minimum cover as stipulated below:

For Distribution and service lines

Minor Water Crossing/Canal	1.5 Meter
Uncased/Cased Road Crossing	1.2 Meter
Rail/Road Cased Crossing	1.7 Meter
Normal Areas	1.0 Meter

The minimum depth may be greater than as mentioned above as may be required by Government/Public authorities under jurisdictions. The Contractor shall perform such work without extra compensation, according to the requirement of concerned authorities.

Also, in case of Drains/Culverts/Utilities crossing through open cut where excavation cut is more than 1.5m, the extra excavation is inclusive in the laying rates. No separate payment is chargeable for extra excavation and includes backfilling as well.

In case, the depth could not be achieved due to practical problems and the same is demonstrated, EIC after examining thoroughly and considering the codes and standards may allow the contractor to provide suitable protection by way of concrete casing pipes or slabs.

13.2 Width of Trench

The width of the trench shall be wide enough to provide bedding around the pipe as specified and to prevent damage to the pipe inside the trench. Unless otherwise directed by the EIC and where ground conditions permit, the minimum distance from the inside edge of the trench wall to the outside of the pipe shall be as per the Drawing no 14588-10-03-27.

13.3 Trench Base

The trench bottom shall be cut or trimmed to provide a uniform bedding for the pipe and shall be free from stones, metal, wood, vegetation, clods of earth or other debris before placement of the pipe.

In case trenching is done in rocky terrain, a bedding of soft soil or sand shall be provided in the trench base at no extra cost to the satisfaction of EIC.

13.4 Hard Rock:

Hard rock is defined as trench material with a single piece of rock, dimension exceeding 1.0 m in any direction, which requires cutting only by use of chisel/pneumatic chisel/drill or sledge hammer or removal of the same by additional excavation technique approved by EIC. Additional rates shall be payable for hard rock excavation as per the SOR over and above the pipeline laying rates. Excavation through soil mixed with small boulders that have been used for a road base will not be considered as hard rock for the purpose of payment.

13.5 MORRUM

Morrums shall be defined as the type of soil, whose excavation is not possible manually, but it can be excavated by mechanical means such as sludge hammer, excavator, pneumatic breaker hammer etc. The SOR shall be applicable only after recommendation from PMC and prior approval from EIC. These rates will be over and above pipeline rates.

13.6 Boulder

It is a rock with grain size of usually not less than 300mm (12 inches) diameter. Additional rates shall be payable for Boulders excavation as per the SOR over and above the pipeline laying rates.

13.7 Clearances

Unless otherwise approved, the following clearances shall be maintained between the external wall of the gas pipe and the external surface of other underground assets/utilities in the vicinity of the Works.

- 150 - 300 mm where the gas pipe crosses other assets/utilities, etc., for electric cables, the clearance shall be 300mm minimum or special protection shall be provided as per approval of EIC.
- 300mm where the gas pipe is on a similar alignment to the other assets/utilities.

Where the above clearances cannot be achieved, or in other special circumstances, the EIC may approve/specify protection with concrete/MS coated pipe, etc. The protective material shall be supplied and installed by the Contractor at his cost subject to discretion of EIC.

13.8 Under Ground Interferences

The Contractor shall locate and expose manually all underground facilities if any during trenching. Safety barriers shall be erected along the trench to prevent any damages or accident. On locations where pipeline is laid under the existing facilities and near the approaches of the crossing, the trench shall be gradually deepened to avoid sharp bends.

All sewers, drains, ditches and other natural waterways encountered while trenching shall be maintained open and functional by providing proper temporary installations if required. Suitable dewatering pumps shall be deployed to dewater, if required.

Whenever it is permitted by Authorities and /or Owner to open cut paved road crossing, or where the line is routed within the road pavement, the Contractor shall remove the paving in accordance with the restrictions and requirements of the authorities having jurisdiction thereof as directed by Owner. After laying the pipeline, backfilling shall be immediately performed and all the areas affected connected with the excavation works shall be temporarily restored.

In case of damage to any of above referred structures/utilities the Contractor shall be responsible for repairs/replacement at his own cost, which shall be carried out to the satisfaction of concerned authorities, resident and Owner.

13.9 Others

Throughout the period of execution of such work, the Contractor shall provide and use warning signs, traffic lights or lanterns, barricades, fencing, watchman etc. As required by the local authorities' jurisdiction and/or Owner.

For all roads, paths, walkways etc. which are open-cut, the Contractor shall provide temporary diversions properly constructed to allow the passage of normal traffic with the minimum inconvenience and interruptions.

The paving shall be resorted to its original condition after the pipeline is installed.

The Contractor shall excavate to additional depth at all the points where the contour of the earth may require extra depth, or where deep trench is required at the approaches to crossings of roadways, railroads, rivers, streams, drainage and ditches without any extra cost implication to Owner.

The Contractor shall excavate all such aforesaid depths as may be required at no extra cost to Owner. The trench shall be cut to a grade that will provide a firm, uniform and continuous support for the pipe.

The Contractor shall take conducive measures to ensure the protection of underground utilities as per the instructions of Owner or relevant authorities.

Where the pipeline crosses underground utilities/structures, Contractor shall first manually excavate to a depth and in such a manner that the utilities/structures are located, then proceed with the conventional methods.

The locations, where the pipeline has to be laid more or less parallel to an existing pipeline cable and/or other utilities in the Right-of-way the Contractor shall perform the work to the satisfaction of the Owner of the existing pipeline/cable/utility. In such locations, the Contractor shall perform work in such a way that even under the worst weather and flooding conditions, the existing pipeline/utilities remain stable and shall neither become undermined nor have the tendency to slide towards the trench.

13.10 Bedding

The Contractor shall ensure that the pipe when placed in the trench is supported and surrounded by a bed of screened excavated soil, which shall be stone free and have a maximum grit size of 5mm, in order to ensure no damage occurs to the pipe. However, in case of rocky soil the bedding shall be done with approved good quality packing sand subject to the approval of the Site Engineer. The packing sand shall be placed to a minimum thickness of 150mm around the pipe in case of rocky terrain.

Unless directed by the EIC the quantity of bedding and surrounding sand shall confirm specifications. There shall be no void space in the packing sand around the pipe.

14.0 LAYING

14.1 Laying of MDPE

Laying of MDPE pipelines shall be commenced only after ensuring proper dimensions and clean surface of the trench. The trench bottom shall be free from the presence of cuts, stones, roots, debris, stakes, rock projections up to 150mm below underside of pipe and any other material, which could lead of perforation/tearing of the pipe wall. After ensuring above, the MDPE pipe coil shall be uncoiled smoothly through proper equipment's/care before laying pipe inside the trench ensuring no damage to pipe.

The contractor must ensure that Pipe caps are provided before lowering of Pipeline. The trench after this can be released for back filling leaving adequate lengths open at the ends for jointing.

Contractors shall ensure open ends of pipe placed in the trench shall be securely capped or plugged to prevent the ingress of water or other matter. The Contractor is to ensure that nothing enters inside the pipe during the laying process as this could cause a future blockage or regulator malfunction due to dust, etc.

In case of open cuts and moiling, where two pipes are to be laid parallel in same trench or same pits, 30% of the respective SOR of the lower size pipe for the laid length shall be paid extra.

Valves shall be installed at locations shown in the Design Plan or as directed by the EIC and joined with PE pipes by electro fusion techniques. The valves shall be placed on a concrete square block at the bottom to achieve equivalent support of the incoming and outgoing pipe.

Laying graphs/As-graphs with details of depth, length, offsets from minimum three (03) fixed different references, other utility crossings, fittings, sizes of the casing pipe used for the pipeline shall be prepared on daily basis and to be submitted to HOGPL representative/ EIC for approval. These details will further be incorporated in to As-Built Drawings.

Pipe may pass through an open drain or nallah with prior approval from EIC. Where this is permitted, the PE pipe shall be installed inside a concrete or steel sleeve for protection with no cost implications to the owner. The sleeve material shall be procured and laid by the Contractor with prior inspection and approval of the EIC for the quality of material. In general, the GI Sleeve material specification shall be confirming to IS 1239 (Heavy Duty) specification of reputed make; cost of GI sleeve shall be paid to contractor as extra item.

In case of service line laying, where the excavated pit for mainline is used for laying of service line, the length of service pipe laid in the same pit and vertical pipe which rises out of the ground with transition fittings shall be paid as per SOR. The contractor shall excavate a minimum pit of size 0.5 meter x 0.5 meter (L X W) on any kind of surface along the wall at the customer premises for the service pipe which rises out of the ground with transition fittings through GI pipe sleeve/Half Round Concrete sleeve. This excavation along with other work necessary to break through the walls of the obstruction, insertion of MDPE pipe, sealing of the annulus between the pipe and the sleeve, sleeve and the wall, installation of sleeve, making of pedestal as per Drawing No 14588-10-03-18 min. Size 300 x 150 x 150 mm for GI Sleeve, min. Size 550 x 230 x 150 mm for Half Round Concrete Sleeve Drawing 14588-10-03-33 and simultaneous restoration of these pits shall be deemed included in the laying rates of pipes respectively. No separate payment of GI Sleeve / Half round concrete sleeve shall be charged to the owner. The material shall be inspected by TPIA / Consultant before installation. Also, the material test certificates, inspection reports approved by TPI/Consultant shall be submitted at the time of submission of bill. Any installation without inspection & approval may lead to penalties as per Special Conditions of Contract.

In case of service lines, EIC shall decide either half round concrete sleeve or GI pipe sleeve shall be installed at any particular site depending upon site condition. The half round concrete sleeve shall be preferred over GI Sleeve, however in case where the installation of half round Concrete Sleeve is not possible due to technical feasibility and site conditions, GI sleeves shall be installed only after written approval from EIC. The rate of GI Sleeve / half round concrete sleeve shall be included in laying of 20/32 mm dia. As per SOR depending upon surface conditions. The details are mentioned below:

14.2 GI Sleeve

The contractor shall supply the minimum dia. Size of 2.5" & 3", 300 mm in length, GI sleeves (Heavy Duty reputed make) respectively for domestic & commercial / industrial installations. The material shall be inspected by TPIA / Consultant before installation. The

material test certificates/ inspection reports shall be submitted at the time of submission of bill.

The installation of GI sleeve for service lines shall be done by sealing the annulus between pipe and sleeve, firm fixing of the GI sleeves by concrete mix pedestal, clamping, sand filling, etc.

The vertical portion of the sleeves shall be fixed to the wall of the premises in a secure manner. The Service lines shall be installed in accordance with the drawing enclosed in the tender.

14.3 Half Round Concrete Sleeve

The installation of Half Round Concrete sleeve for service lines shall be done by sealing the annulus between pipe and sleeve, firm fixing of the Concrete sleeves by concrete mix pedestal, clamping, sand filling, etc. Half round concrete sleeve shall be made as per attached drawing no 14588-10-03-33 as per instruction of EIC. The dimensions shown are tentative and may vary depending upon the site conditions. The material shall be inspected by TPIA / Consultant at the fabrication stage & prior to final dispatch at site for installation. The material test certificates/ inspection reports shall be submitted at the time of submission of bill.

14.4 Crush Guard/ half Round Concrete Sleeve: - (For O&M and Project)

The installation of pre-cast RCC crush guard over Half Round Concrete Sleeve/ Pedestal shall be done by installing it resting on wall of building by fixing it with grouting nut and bolts in wall that may be detached during the event of leakage/testing. The material shall be inspected by TPIA / Consultant at the fabrication stage & prior to final dispatch at site for installation. The material test certificates/ inspection reports shall be submitted at the time of submission of bill.

The Crush Guard shall be installed in accordance with the drawing no. 14588-10-03-33 enclosed in the tender as per instruction of EIC.

14.5 LAYING OF SERVICE LINE IN PROJECT AND O&M AREA:

14.6 For Pipe length upto 5 mtrs

Includes laying of pipeline (for 20/32/63 mm) in all type of surface i.e Kutcha,metal,concrete (PCC/RCC),bituminous, tiles, brick, land etc after racking up of hard surface of any type by any methodology, connection of laid pipeline with existing charged line using Saddle/Tee. Roads,Pavement,Footpaths etc shall be restored to original state once the pipeline is laid. Supply & installation of GI Sleeve /Half round Concrete sleeve shall be included in laying rates. Supply & Installation of GI Sleeves 2.5inch NBx300 mm length Half Round Concrete Sleeves for domestic connection, 3inch NBx300mm length GI Sleeve for commercial and industrial installation, Supply & installation of TF. Excavation, breaking through any obstructions, insertion of pipe, sealing the annuls, fixing of the sleeves with concrete mix, preparation of pedestal & restoration of excavated pits within the size of pedestal & restoration of all pits with the laying of 20/32/63mm as defined and instruction of Owner/Client. Providing As-laid drawing. No additional cost for restoration shall be paid extra over and above laying rates. Liasioning with Landowning agencies/statutory authorities, preparation of detailed route plan, making trial pits to determine the underground utilities/services etc. Obtaining permission from Land owning agencies shall also be in contractors scope wherever service lines are to be laid after dismantling drain, No additional cost for dismantling and restoration/repairing shall be paid extra over and above laying rates.

15.0 JOINTING OF POLYETHYLENE PIPE

The procedure for jointing of PE pipe and fittings machines is attached as Annexure #2 and as per Specification for ELECTROFUSION FOR PE PIPES AND FITTINGS. Only Bar coded into

electro-fusion machine (Automatically Readable) that can read the bar code of the fittings automatically shall be used for joining of the MDPE pipes/fittings. Manual feeding Electro-fusion machines are not acceptable for jointing purpose. The contractor has to submit the certificate of calibration of Fusion machine at the time of start of work and at fixed intervals as per the instructions of Owner. Contractor shall ensure that the machines are always available at site. No stoppage of work due to the non-availability of machines shall be allowed.

The contractor shall flush the Pipeline with air to remove dust, water, mud etc. before fusing the joints. Before jointing, the Contractor shall place packing sand under the pipes on both sides of the joint to keep the pipes in line and at the correct alignment during the jointing process. The jointing process shall start only after Alignment clamps with the correct size are aligned with the pipe and coupler during the electro-fusion cycle.

The Contractor shall ensure that polyethylene pipe is only cut with an approved plastic pipe-cutting tool (Rotary Cutter up to 63mm/Guillotine Cutter for 63mm and above). Before fusion is attempted, the contractor shall remove the oxidized surface of the pipe using Universal Scrapper up to 63mm/Rotary Peeler for 63 mm and above before inserting into the electro-fusion coupler. The tool must remove a layer of 0.1mm to 0.4mm from the outer surface of the polyethylene pipe. No fusion will be allowed without clamping device and the approved cutting tools (Hack saw shall not be allowed for cutting the pipe).

The contractor has to supply all the consumables required for carrying fusion of the joints (like tissue paper, napkin, acetone etc.).

If, upon inspection, the EIC determines a joint is defective, Contractor shall remove the joint by an approved method. The cost of replacing joint shall be borne by the Contractor including the cost of pipe and fittings removed.

For electro-fusion joining, the contractor must bring own tools, tackles and equipment's. Only, approved Jointers shall carry out fusion of all joints. Contractors shall provide the list of jointers to be used on the job and make arrangements for Qualification Testing of the jointers in presence of Owner / Owner's representative as per the standard procedures. All approved Jointers shall bear identity cards signed by Owner / Owner's representative during fusion job and shall furnish the same on demand by Owner / Owner's representative. Applicable penalties shall be levied, in case; it is found that fusion is being carried by non-qualified jointers as per the provisions made in Special Conditions of the Contract.

Contractor shall arrange generator along with voltage stabilizer for power supply to fusion machine. Taking power connection from electric poles, connections without written permission from the concerned authorities or residential premises is strictly not permitted.

16.0 BACKFILLING

Backfilling shall be done after ensuring that appurtenance have been properly fitted and the pipe is following the trench profile at the required depth that will provide the required cover and has a bed which is free of extraneous material and which allows the pipe to rest

smoothly and evenly. Dewatering shall be carried out prior to backfilling. No backfilling shall be allowed if the trench is not completely dewatered.

Prior to backfilling it should be ensured that the post padding of compacted thickness 150 mm is put over and around the pipe immediately after lowering where required.

Backfilling shall be carried out immediately after the post padding where required has been completed in the trench, inspected and approved by Owner/ Owner's representative, so as to provide a natural anchorage for the pipe avoiding sliding down of trench sides and pipe moment in the trench. If immediate backfilling is not possible, a padding of at least 300mm of earth, free of rock and hard lumps shall be placed over and around the pipe and coating.

The backfill material shall contain no extraneous material and/or hard lumps of soil, which could damage the pipe and/or coating or leave voids in the backfilled trench. In case, it is

required and directed by EIC screening of the backfill material shall be carried out with specified equipment before backfilling the trench.

The surplus material shall be neatly crowned directly over the trench and the adjacent excavated areas on both sides of the trench to such a height which will, in Owner/Owner's representative opinion of provide adequately for future settlement of the trench backfill during the maintenance period and thereafter. The down shall be high enough to prevent the formation of the depression in the soil when backfill has settled into its permanent position should depression occur after backfill, Contractor shall be responsible for remedial work at no extra cost to Company. Surplus material, including rock left from this operation shall be disposed off to the satisfaction of landowner or authority having jurisdiction at no extra cost to Owner.

Where rock, gravel, lumps of hard soil or like materials are encountered at the time of trench excavation, sufficient earth, sand or select backfill materials shall be placed around and over the pipe to form a protective cushion extending at least to a height of 150 mm above the top of the pipe. Select backfill materials for padding that area acceptable shall be soil, sand, clay or other material containing no gravel, required selected backfill material has been placed, provided the rock or lumps of hard soil. The padding earth shall not contain any stones, i.e. the earth shall be screened for sand padding of the Pipeline in order to avoid damage to the pipeline. Contractor shall carry out all these works at no extra cost to Owner. Loose rock may be returned to the trench after the required selected backfill material has been placed, provided the rock placed in the ditch will not interfere with the use of the land by landowner, or tenant.

In case where hard rock is encountered or as desired by EIC / site engineer sand padding is to be provided up to height of 150 mm around the pipe.

When the trench has been dug through driveways or roads, all backfilling shall be executed with sand/suitable material in layers as approved by Owner /Owner's representative and shall be thoroughly compacted. Special compaction methods as specified may be adopted. All costs incurred there upon shall be borne by the Contractor. Trenches excavated in dikes which are the properties of railways or which are parts of main roads shall be graded and backfilled in their original profile and condition. If necessary, new and/or special backfill materials shall be supplied and worked-up to.

PE Warning Grid/Mat shall be placed on distribution main and service line inside premises, after backfill of the trench up to a height of 300mm on the top of the carrier pipes. The warning grid is to be unrolled centrally over the pipe section and thereafter further backfilling will commence.

Backfilling activity shall include proper compaction by jumping jack compactor, wherever required and as per instruction of EIC, and watering in layers of 150mm above the warning mat. Proper crowning of not more than 150mm shall be done. All the excavated

material that could be used during the Restoration process shall be stacked and kept separately and properly. Wherever Road cutting/Tiles removal/PCC cutting has been done during excavation for laying, the area shall be back filled and compacted immediately so that no inconvenience is caused to the general public.

Electro-fusion of joints is to be undertaken immediately after lowering and the activity shall not be kept pending for lack of Electro-fusion jointing. The backfilling shall be considered complete only after the jointing of pipes.

Debris and other surplus material shall be removed immediately after the back filling.

The contractor shall not be entitled for payment as defined in commercial on laying and backfilling till the above activities are completed.

17.0 MOLING

The Manual Moling shall be carried out as per the requirement specified by Owner / Owner's

representative and approved procedures. The contractor has to carry out survey of the underground utilities before going for the Molding to avoid any damage to other utilities. No extra payment will be made for any trial/abandoned pits made during the survey. The supply of all equipment required for carrying out molding work is in contractor's scope. The type of molding to be carried out i.e. with or without casing shall be at the discretion of Owner and prior approval is to be taken before starting the Molding.

For Molding the contractor shall ensure that the size of the hole shall not be more than 20% of the size of the casing/carrier pipes whichever is applicable. After completion of Molding the hole shall be properly compacted / filled with soil by watering and by approved procedures.

The molding rates are payable as per the SOR item no. 1 & 2 and the molding rates are common for MDPE pipe laying with or without casing pipe through the hole. The length of the Hole (excluding the sizes of the pits on both ends) shall be considered for the measurement of Molding length. However, the extra length of casing shall be considered for material consumption purpose only. Further, the payment for the pipeline laying in the excavated pits for Molding purpose will be made as per the SOR for normal laying.

Any damage occurred to other utilities during the molding operation shall be immediately, notified and rectified by the contractor without any cost implication to owner.

18.0 HORIZONTAL DIRECTIONAL DRILLING (HDD)

HDD is required to be carried out by the Contractor where conventional Trenching/Molding is not possible viz. Railways, major waterways, highways, roads, congested areas etc. The Contractor shall obtain details of such crossings and the Contractor in consultation with Owner shall prepare construction drawings. Execution of the work shall be based on the Owner / Owner's representative approved drawings. The contractor has to do the thorough survey of the underground utilities before commencement of HDD to avoid the damage to the other utilities. No other extra payment will be made for any trail/abandoned pits made during the survey. The supply of all equipment required for carrying out the HDD is in contractor's scope. The HDD operation shall be carried out in accordance with API-1102. The type and availability of machines is sole responsibility of the contractor and as per the site conditions & requirements to entire satisfaction of EIC.

Once the work is allotted, any delay in mobilizing / non-availability of HDD machines as per site requirement and conditions shall result in levying of penalties on daily basis as per SCC. However, in such cases, owner shall mobilize HDD machines and carry out execution of work on the contractor's risk and cost and as per SCC.

The type of HDD to be carried out with or without casing shall be at the discretion of Owner and prior approval is to be taken before starting the HDD.

As per the specification, HDD to be carried out with or without casing pipe depends on the type of crossing as per instruction of Owner/ Consultant.

Any damages occurred to other utilities during the HDD operation shall be immediately notified and rectified by the contractor without any cost implication to OWNER.

There are no separate rates for HDD, rates are payable only as per SOR 1,2.

19.0 CASING PIPE

The tentative sizes of the HDPE casing pipe for Moling/Horizontal Directional Drilling shall be as follows:

S. No.	MDPE Carrier Pipe Dia. size (mm)	Min. Dia. of HDPE Casing Pipe (mm)	Max. Dia. of HDPE Casing Pipe (mm)
1	32	50	90

However, the size of the casing pipe may vary according to the length of the carrier pipe and requirement of laying of HDPE duct & OFC cable, if required. Also, the higher size of HDPE casing pipe shall be preferred over lower size casing pipe without any extra cost to the Owner.

20.0 RESTORATION

Wherever the restoration to the original surface condition is in the scope of Owner or as directed by EIC, all roads, footpaths (including roads and footpaths inside colonies) shall be restored to its original condition and the same shall be done as per CPWD/IRC norms and to the satisfaction of the concerned local Authority/Third Party Agencies designated by Owner. To retard curing of the installed concrete, wet sackcloth is to be placed on the finished surface and kept damp for a period of 7 days.

Where slabs and blocks are to be restored, the level of the compacted sub-base is to be adjusted according to the slab/block thickness. The slabs or blocks should be laid on moist bedding material, which should be graded sand, mortar or mortar mix. The slabs or blocks should be tapped into position to ensure they do not rock after lying.

The restored slabs or blocks should match the surrounding surface levels. Joint widths should match the existing conditions and be filled with a dry or wet mix of mortar. The procedure for restoration of Road/Footpath is just indicative. However, the restoration shall be done in accordance with the norms of the concerned Land-owning agencies.

Turf shall be replaced in highly developed grassed area. In lesser-developed grassed areas top soil should be replaced during the restoration process.

Where permanent surface restoration cannot be completed immediately, the Contractor shall provide and maintain a suitable temporary running surface for vehicular traffic and pedestrians. The Contractor will be responsible for the maintenance of all restoration carried out, for the duration of the Contract guarantee period.

The Contractor is to ensure the restoration work is properly supervised and that the material used is suitable for the purpose and properly compacted. Where the required standards are not achieved, the Contractor will be required to restore the defective work.

Contractor has to obtain the No Objection Certificate (NOC) from the concerned local authorities/RWA after completion of the restoration work. The restoration specification specified in the tender is only a typical specification and the contractor has to carry out

restoration as per the latest version CPWD/IRC/MCD specification to its original condition and also to the entire satisfaction of landowner (Private/Public).

The expenditure incurred towards testing of the material used for restoration, as per the applicable standards, shall be borne by contractor.

There shall be no separate rates for restoration, SOR 1,2 is all inclusive of restoration charges.

21.0 TESTING

Pressure testing will be carried out with compressed air (free from oil and greases). Compressed air will be provided by Contractor for testing purposes and is to be included in the laying rates.

For main pipeline laying, the Contractor shall perform progressive pressure testing to ensure no leaks in long lengths of pipe. The test pressure shall be 6.0 bar (g), and there shall be no unaccountable pressure loss during the test period.

Overall scheme drawing for pressure testing shall be prepared by the contractor and get approval from Owner/Owner representative.

For main line the test duration shall be 24 Hrs. with these tests, the pressure should be allowed to stabilize for a period of 30 minutes after pressurization. The holding period may then commence and continue for 24 hours. Measuring instruments shall have been calibrated and their accuracy and sensitivity confirmed. For testing of Network, calibrated pressure gauges of suitable range shall be supplied by the contractor. The pressure gauges shall be calibrated from time to time as desired by EIC. All testing shall be witnessed and approved by the EIC or his delegated representative. Tie-in joints may be tested at working pressure following commissioning. In special cases, where the mainline length is less than 500 mtrs, holding period for testing may be reduced to 4 hrs.

For service lines up to a length of 15 mtrs testing will be carried out independently of the testing of the mains (if service line is laid separately after commissioning of mainline) for which the test duration may be reduced to 30 minutes at 6 bar (g) pressure. The service line testing in this case will be performed after the service line installation is complete but before the service line tee has been tapped. Also in some cases the tapping of the service tee will be delayed pending the completion and purging of the main pipelines.

22.0 PURGING

Purging shall be carried out in accordance with the principles defined in the American Gas Association publication "Purging Principles and Practice".

The Contractor shall also provide nitrogen required for purging as per the direction of Site In-charge. Nitrogen shall be supplied in labeled, tested and certified cylinders and completed with all necessary regulators, hoses and connections, which will be in good and working condition. No separate payment shall be paid for supplying Nitrogen cylinders for purging and is included in the laying rates. Before purging cylinder should be checked for containing Nitrogen only.

In addition, the Contractor shall submit purging plan and get approval from Owner / Owner representative before commencing any purging work. The Plan shall include, but not be limited to the provision of the following materials and equipment: Personal Safety Equipment, Fire Extinguisher, Purging Adaptor, Purge stack with flame trap and gas sampling point, Gas sampling equipment (may be gas leak detector), squash-off tool, Polyethylene connecting pipe.

The Plan shall also include the purging process along with detail on the sequence of events. The process is to also specifically mention the need to lay a wet cloth over the PE main and in contact with the ground, to disperse static electricity during the purging work.

A purge stack with flame trap shall be used when purging services. Care shall be taken to ensure that the purge outlet is so located that vent gas cannot drift into buildings.

24.0 CONSTRUCTION OF TRENCHES AND OTHER SCOPE OF WORK IN BUILDER SEGMENT-

24.1 Construction of dedicated trench (as per approved drawing)

Trench Dimension- 0.6m x 0.66m x 1.0m (d x w x l)

Scope includes excavation of trench in any type of surface, construction of brick wall, waterproofing of trench (If required), removal of surplus malba, plastering of walls, watering and curing including supply & installation of precast RCC slab covers Site cleaning and restoration of all damaged surfaces during construction activity. Contractor should submit NOC through concerned RWA/Builder/Authority. For other details please refer drawing no14588-10-03-34

24.2 Construction of dedicated trench (as per approved drawing)

Trench Dimension- 0.375m x 0.66m x 1.0m (d x w x l)

Scope includes excavation of trench in any type of surface, construction of brick wall, waterproofing of trench(If required), removal of surplus malba, plastering of walls, watering and curing including supply & installation of precast RCC slab covers Site cleaning and restoration of all damaged surfaces during construction activity. Contractor should submit NOC through concerned RWA/Builder/Authority. For other details please refer drawing no.- 14588-10-03-35

24.3 Excavation of trench and installation of casing pipe by any method (Open /Moling)

Scope includes excavation of trench/moling in any type of surface and installation of 6" GI Pipe C Class as casing pipe, restoration for road crossing up-to 7.0 m inside society and obtaining NOC through concerned RWA/Builder/Authority.

Note- In case of restoration SOR shall be applicable over and above this SOR.

24.4 Sand Filling in any type of trenches in builder segment only;

Scope includes supply and filling of coarse sand (Size 0.6 To 2.0mm) as per IS 383 free from impurity like clay, mica and soft flaky pieces in the trench as per instruction of EIC/Owners representatives.

Note- Actual qty. (Cu.M) of sand filling shall be claimed as per SOR

Note- In all of the above items 10% amount shall be withheld till availability of NOC from concerned authority.

25.0 ROUTE MARKERS

Route Markers shall be fabricated, supplied, and installed on the ROU at regular intervals as per the instructions of the EIC immediately after laying of the Pipeline. The installation of the type of the Permanent Marker shall be decided by the EIC depending on the site condition. The contractor shall also ensure that a sample of all type of markers shall be inspected and approved by Owner / Owner representative before shipment of the lot at site and prior to installation at the site. The inspection of all types of markers shall be carried out lot wise.

The Stone Markers shall be painted before installation as per the approved procedure.

Whereas the Pole marker (Markers with foundation) and plate marker are to be supplied with powder coated Golden Yellow paint The supply of the paint as per drawing no14588-10-03-29 and application. The supply of paint and application as per the specification is in contractor's scope. Payment shall be paid as per relevant SOR item no. 8a, b & c.

Contractor shall obtain the approval lot wise & before installation at site from the Consultant / TPIA.

26.0 GUIDELINES:

- The installation of these markers shall be such that in between two pole markers two Stone markers are installed with spacing of 50 mtrs on either side. However, Pole markers shall be installed at all the Tapping /Branching points in the mainline.
- Interval between any two Stone Route markers for mainline (180mm to 63mm) shall not be more than 50m.
- A Pole marker shall be installed near to valve chambers on Mainline & inside the pockets respectively for indication.
- Pole markers with foundations (As per the Drawings in Tender document) shall be installed after two Stone markers.
- The entry and exit pits for laying of pipeline by HDD / Moling for Road crossings shall be marked by Pole markers or Stone markers depending upon the site conditions.

In addition to above, Pole markers with foundation (As per drawings in Tender document) shall be installed outside of individual societies/areas as per the instructions of the Owner representative.

- For the distribution network 32mm & 20mm pipe, Stone / plate markers shall be installed as per the site conditions and directions of the Site-in-Charge.
- The artwork is typical for all the markers, with Owner's logo on it. The contractor must take prior approval for the artwork from EIC before installation of Markers. The lot wise approval shall be attached with bills.

27.0 ASSISTANCE IN COMMISSIONING

Contractor shall provide the required personnel, Vehicles, labour, supervision, tools, equipment, instruments and technical assistance for performance tests and commissioning activities as per requirement / satisfaction of Owner /Owner's representative.

28.0 STANDARD OF WORK

All work carried out under this contract shall be to standards, codes of practice construction procedures and other technical requirements as defined in the technical specifications. The manpower deployed on the respective work shall be adequately trained and shall have necessary skills to execute/supervise the work. However, the assessment on the qualification of the personal shall be at the discretion of EIC.

Fusion Operators and other skilled personnel like plumbers, conversion techniques shall be approved by Consultant/ Owner. Simultaneously Identification Cards duly signed by Consultant/ Owner shall be issued to them. The contractor shall maintain proper record for the identification cards issued to their workers.

29.0 RECORDING (AS-BUILT DRAWINGS)

- The following points shall be taken care to the preparation of as built drawings.
- The as built drawings should be in the scale of 1:200 and shall be submitted in an A-0 sheet. The drawings shall be in layers according the AUTOCAD features category.
- Pipeline feature shall be shown as a continuous line, breaks only at joints, fittings,

valves, tee point, etc. Diameter, Pipe material, length, and location of pipeline whether on the road or footpath, should be clearly indicated.

- Minimum three (03) offsets of every joint, from permanent structure shall be recorded on As Built.
- Distance of pipeline from permanent property/structure should be provided at least every 20 mtrs. If there is any change in alignment / orientation and offset distances etc. Of the pipeline in between the above said 20 mtrs, the same shall be clearly mentioned in the as laid. Gas objects (off valves, tees, elbows, couplers, transition fittings etc.,) shall be shown as block objects (which form a single node to connect) with respect to Owner symbols / legend. The As laid drawings shall be as per the approved legends provided by EIC.
- Details & offset distances from other utilities present (e.g. MTNL, NDPL, BSES, DJB etc.) should be given in as laid drawing. If there is any change in depth of the pipeline, the same shall be clearly marked with details in the as laid drawings. The details (material, size & Length) of additional protection provided to pipeline shall also be clearly indicated.
- Details of the PE stop off valves & Other fittings used (i.e. tees, elbows, couplers, transition fittings, etc.) should be shown with adequate information orientation & Offsets from permanent structures in the immediate vicinity.
- Technical deviations (if any) should be provided with reference to the buildings permanent structures around, and the same should be cited clearly with all the relevant details, including separate sketches/Blowups / sectioned drawings / exploded view.
- Total as laid-length (size wise), bill of materials should be mentioned in each sheet.
- Complete details of nallah crossings should be shown in a separate sketch.
- Names of roads, major landmarks and buildings should be mentioned appropriately for reference.
- Proper chainage shall be mentioned on all the drawings to be referred with continuation reference.
- Direction of gas flow shall be indicated in each of the drawings.
- Text on the as laid drawing should be clearly visible.
- Land base features shown on the drawing shall match the exact distance as they were on real ground with respect to scale (1:200).
- As built drawings shall be duly signed & stamped by area TPIA / Consultant.
- The details shall be prepared in standard format using MAP INFO/AUTOCAD MAP and submitted CD RAM. Contractor shall also make the item wise material consumption report for the respective areas in a soft copy and to be submitted along with the as-built drawings.

30.0 CIVIL WORKS

The contractor has to supply the adequate materials and skilled manpower for the completion of all the civil works. The contractor shall also ensure that the work is carried out as per the details mentioned in the Schedule of rates.

Special cares shall be taken at the time of labours working in depths/lifting of the skids by hydras/ cranes considering all the safety guidelines.

The contractor has to ensure that sample of the all the materials shall be inspected and approved by EIC before carrying out installation or erection work. The contractor has to submit the test certificates for all the materials to be used at the site. The construction shall be carried out strictly as per the drawings provided by the HOGPL/Consultant. The contractor shall ensure extra / surplus materials / malba shall be immediately removed from the site after completion of the job. Separate payments shall be made as per the SOR.

ANNEXURE # 1

TOOLS & EQUIPMENTS TO BE PROVIDED BY THE CONTRACTOR FOR PRE-LAYING

Sl. No.	Equipment Details	Minimum Requirement (In Nos.)
1	Electro Fusion Box (Automatically readable)	2
2	Voltage Stabilizer	1
3	Generator (5.5 KVA)	2
4	Moiling Equipment (for all sizes)	As and when required
5	HDD Machines & Equipment (for all types & sizes)	As and when required
6	Squeeze Tools (Manual) up to 63 mm	2
7	Squeeze Tools (Hydraulic) from 63 mm up to 180 mm	2
8	Rotary Peelers	2
9	Universal Scrapers	3
10	Tapping Tools/Allen Keys	Two sets of all sizes
11	Pipe Cutter (Round)	2
12	Pipe Cutter (Guillotine)	1
13	Pipe Cutter (ratchet type)	2
14	Gas Detection Unit	As and when required
15	Cable and Pipe Locator	As and when required
16	Test Ends	One set of all sizes
17	Pipe Alignment Clamps	As and when required
18	Joining Clamps for Coupler (All sizes)	2
19	Joining Clamps for Saddle (All sizes)	2
20	Pipe Straightness	As and when required
21	Re-rounding Tools (All sizes)	As and when required
22	Jumping Jack Compactor	As and when required
23	Roller for Asphaltting	As and when required
24	Calibrated Pressure Gauges (0-6 Bar)	6
25	Water Tankers	As and when required
26	Automatic Thread cutting machine	As and when required
27	GI Pipe cutter	As and when required
28	Heating Element for HDPE Butt joint along with clamping, roller and other accessories	As and when required

ANNEXURE # 2

FUSION COUPLERS FROM 20MM TO 180MM

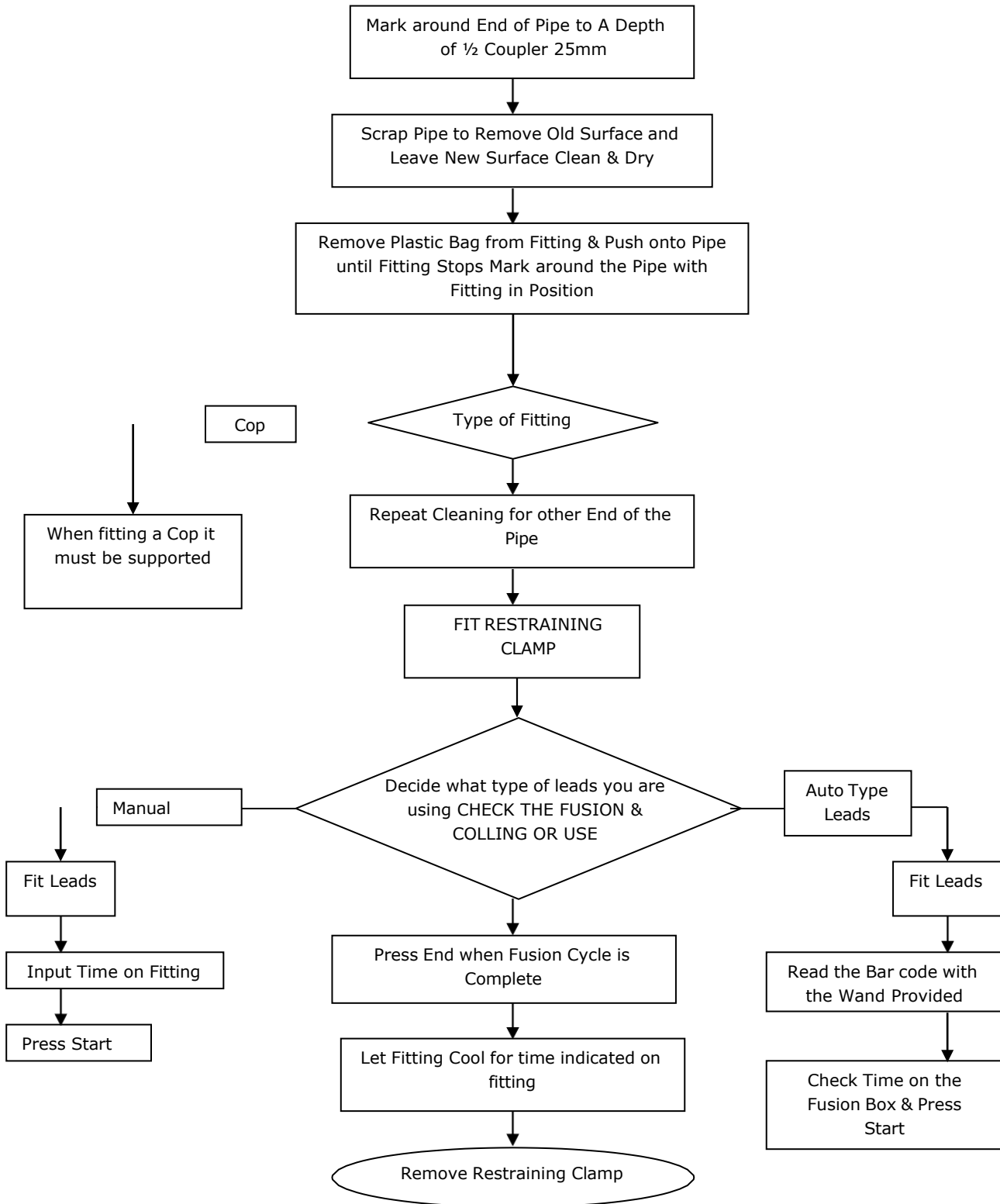

ANNEXURE # 3

RESTORATION PROCEDURE/GUIDELINES FOR ROAD CUTS OF MCD AND OTHER LANDOWNING AGENCIES

PURPOSE AND OBJECTIVE

The main purpose and objective of this document is to ensure that all the work are carried out with proper specifications and standards with high quality and timely accomplishment, and the restoration of infrastructure is according to standards Aimed at achieving the original condition of the road infrastructure.

DOCUMENTS/FILES TO BE MAINTAINED:

The following documents shall be maintained during execution of the job and shall be handed over to OWNER/Consultant/TPI after completion of the job;

- Copy of permission letter obtained from MCD.
- Drawing/Sketch showing the details of stretch to be cut, highlighting the type of surfaces and its chainage/length (area)
- Stage wise Photographs of the stretch.
- Test Certificates of the Construction materials to be used.
- Routine Test Certificates for construction materials during progress of job.

31.0 RESTORATION OF TRENCHES/PITS:

After laying pipeline, backfill material without containing extraneous material or hard lumps of soil or stones shall be filled and watered in layers of 150mm. Warning mats shall be placed as per specification. Earth shall be filled watered and compacted in layers with the help of earth compactor (Jumping jack compactor where ever space is available). After backfilling, the crown of the earth shall be between 50mm and 100mm above road surface and shall be free from sharp-edge stone and boulders.

After consolidation of backfill, the surplus earth shall be removed and disposed at place directed by OWNER (at suitable locations, as per direction of MCD)

Further, depending upon the Surface types of following specification shall be adopted:

Sl. No.	Surface Types	Specification Recommended
1	Cement Concrete Surface	Top Surface – PCC 1:2:4, 100 mm Thick Compacted with Plate Vibrator shall be laid over base course. Base Course – PCC 1:5:10, 75 mm Thick laid over compacted backfilled earth.
2	Brick Soiling	Top Surface – Brick Soiling (as per original type) shall be laid over base course. Base Course – PCC 1:5:10, 75 mm Thick laid over compacted backfilled earth.
3	Interlocking CC Paver Block	Top Surface – Interlocking CC Paver Blocks (as per original type) shall be laid over compacted fine sand 50 mm Thick over base course. Base Course – PCC 1:5:10, 75 mm Thick laid over compacted backfilled earth.
4	Chequered Cement Concrete Tiles/Pre-cast CC Tiles/Kota Stone Floor/Red Stone Floor	Top Surface – Tiles/Floor (as per original type) shall be laid over Cement Sand Mortar 1:6, 20mm Thick over base course, Joints shall be pointed/finished to match colour. Base Course – PCC 1:5:10, 75 mm Thick laid over compacted backfilled earth.
5	Bituminous Surface (for Category D Roads i.e.; Roads less than 13.70 M width)	Top Surface – 40mm Thick Bituminous Concrete (as per original type) shall be laid over PCC 1:2:4, 100 mm Thick over base course. Base Course – PCC 1:5:10, 75 mm Thick laid over compacted backfilled earth.
6	Bituminous Surface (for Category C Roads i.e.; Roads less than 18 M width but greater than 13.70 M width.)	Top Surface – 40mm Thick Bituminous Concrete (as per original type) shall be laid over PCC 1:2:4, 150mm Thick over base course. Base Course – PCC 1:5:10, 150 mm Thick laid over compacted backfilled earth.

The specification mentioned above may be modified in line with relevant MCD/CPWD/IRC specifications. Contractor has to follow the changes as informed to them time and again.

NOTE:

Wherever the Bituminous portion is cut in small patches or isolated location where area of Bituminous portion is very less due to constraints like other utilities, the

surface shall be restored, same as specified for the cement concrete surface, with prior approval of EIC/TPI.

32.0 TESTING OF CONSTRUCTION MATERIALS

For the different construction materials proposed to be used the following tests are required to be carried out for approval:

Sl.No.	Material	Test	Method of Testing	Frequency of Test
1	Cement	Setting time, soundness, compressive strength and fineness	As per IS: 4031	Once for each consignment or as and when required/directed
2	Bricks	Compressive strength, water absorption and efflorescence	As per IS: 3495	Minimum five samples or as per IS: 5454
3	Coarse Aggregates	Sieve analysis, flakiness index, estimation of deleterious materials, organic impurities, moisture contents and specific gravity	As per IS: 2386	One test per source of supply and routine test regularly as directed
4	Fine Aggregates	Sieve analysis, clay silt and moisture contents and specific gravity	As per IS: 2386	One test per source of supply and routine test regularly as directed

In addition to the above construction materials such as inter locking paver blocks, chequered cement concrete tiles, Pre-cast CC tiles, Kota/Red Stones Flooring samples shall be arranged for approval before use and if required testing shall be arranged.

For Cement concrete works the minimum frequency of sampling of concrete (CC cubes) shall be as follows:

Sl. No.	Quantity of concrete in Cu. M	No. of Samples
1	1 - 5	1
2	6 - 15	2
3	16 - 30	3
4	31 - 50	4
5	51 and above	4 + 1 additional sample for each additional 50 Cu. M and part thereof.

The cement concrete cubes shall be tested for 7 & 28 days as per relevant IS code.

33.0 INSPECTION BY THIRD PARTY INSPECTION (TPI) AGENCIES NOMINATED BY LAND OWNING AGENCIES

It is the responsibility of the contractor to give inspection call, at least one week in advance to OWNER, to arrange for inspection by TPI nominated by land owning agencies along with the file containing all documents mentioned in Clause No. 2 of this document. Before inspection by TPI nominated by land owning agencies, contractor has to arrange for the inspection of the restored area by OWNER/Consultant/TPI and get the work certified. Contractor has to arrange for all necessary equipment, tools & tackles, labour for carrying out the inspection of the restored area. It is the responsibility of the contractor to obtain "No Objection Certificate" (NOC) from the TPI nominated by the landowning agencies and further NOC from Land Owning Agencies and to get the securities/Bank Guarantees paid to them, for obtaining the permissions.

STANDARD SPECIFICATION -
INSTALLATION OF ABOVE GROUND GI
PIPING & FITTINGS IN LOW RISE
DOMESTIC CONNECTIONS

CONTENTS

1.0	GENERAL INFORMATION	3
2.0	DEFINITIONS	3
3.0	SCOPE OF WORK	4
4.0	MATERIAL, MANPOWER EQUIPMENT AND MACHINERY	6
5.0	ISSUE OF WORK INSTRUCTIONS	8
6.0	PROGRESS OF WORK.....	9
7.0	WORK SHEETS.....	9
8.0	PERMISSIONS / APPROVALS	9
9.0	REFERENCE SPECIFICATION, CODES AND STANDARDS.....	10
10.0	RIGHT-OF-USE SERVEY AND MARKING.....	10
11.0	PROTECTION OF STRUCTURES AND UTILITIES	11
12.0	POWDER COATED GI AND COPPER ABOVE GROUND SERVICE PIPE	11
14.0	INSPECTION.....	15
15.0	PURGING & COMMISSIONING	15
16.0	RESTORATION	15
17.0	SUBMISSION OF FINAL RECORDS	16
18.0	COMPLIANCE TO HEALTH, SAFETY & ENVIRONMENT (HSE) FOR LOW RISE GI.....	16

1.0 GENERAL INFORMATION

HPOIL Gas Private limited (HOGPL) consortium of HPCL & OIL has received the authorization from PNGRB vide letter PNGRB vide letter PNGRB/CGD/BID/8/2018/GA/Ambala-Kurukshetra District dated 22/02/2018 and PNGRB/CGD/BID/8/2017/BEC/GA-Kolhapur dated 06/03/2018, to Lay, Build and Operate City Gas Distribution networks in Ambala-Kurukshetra and Kolhapur District. HOGPL (hereinafter referred as Owner), is supplying Piped Natural Gas (PNG) to domestic, commercial and Industrial consumers and Compressed Natural Gas (CNG) to automobiles in Ambala-Kurukshetra and Kolhapur District.

VCS Quality Services Pvt. Ltd. (VCS has been appointed as Project Management Consultant for providing consultancy services for CGD Expansion Project for PNG in Ambala-Kurukshetra & Kolhapur (hereinafter referred as Consultant), by HOGPL

The main scope of this contract comprises the installation of above ground pipes from the outlet of 'PE/GI transition fitting' up to the domestic/commercial Customers 'Appliance/stove/oven valve' as per the Distribution schedule placed in enclosed drawing No:14588-20-05-01 in New as well as in Existing Gas charged areas.

The scope includes installation & procurement of above ground GI pipes and associated fittings for commercial/domestic consumers. However, the piping may have to be carried out up to isolation Valve, in case of some commercial/domestic customers required.

Except domestic meter, regulator, Isolation and appliance valve, Contractor shall procure each material (GI fittings, GI Pipes, Cu Pipes, Cu/Brass fittings, etc.) which is required from the out of PE/GI transition fitting up to the Domestic/Commercial Customers "Appliance/stove/oven valve".

This technical specification defines the basic guidelines to develop an acceptable design and suitable construction methodology for carrying out different activities listed out in the schedule of rates of this tender.

Compliance with these specifications and/or approval of any of the Contractor's documents shall in no case relive the contractor of his contractual obligations.

2.0 DEFINITIONS

OWNER	HPOIL Gas Private limited (HOGPL)
PMC	VCS Quality Services Pvt. Ltd. (VCSQSPL)
SS	Present <<Standard Specification>> and its entire appendix, if any
TPIA	Third Party Inspection Agency to be appointed by HOGPL
EIC	Engineer-in-charge
CUMULATIVE LENGTH	The riser length (excluding lateral tapping) shall be considered and averaged out among all the households, whereas the lateral piping shall be included only for one

	particular connection
RIV PIECE	The GI pipe from transition fittings to Riser Isolation Valve

3.0 SCOPE OF WORK

Generally, the following shall constitute the Contractor's scope of work but not limited to:

- Plan and prepare a schedule for execution and work implementation as per QA/QC plans to be issued by Owner/Owner's representative. Contractor has to submit the Construction/Execution procedures before commencement of work to Owner / Owner's representative for approval.
- Contractor shall submit the QCT/procedure/drawing etc. of all the material to be procured by him for approval before procuring the items. If, QCT/procedure/drawing etc. are not approved from client/consultant then owner has the authority to refuse /reject the same lot material.
- Receipt of meter regulators, domestic meters, as a free issue items from Owner's stores, loading, transportation, unloads at project site. Proper storing, stacking, identification, providing security and insurance during and before installation and commissioning of pipelines. Obtaining the approval for optimum route and permission for work from the concerned authority and EIC.
- Selection of route with the EIC/Consultant and marking the same on walls/floors between 'transition fitting' to 'cooking oven/stove/appliance', making openings and making provisions for fixing clamps. Making temporary but stable platforms/scaffolding /rope ladder etc., required for installation of pipes/fittings at all heights/multi storied flats and locations.
- Contractor shall procure all material except free issue items for installation at the outlet of PE/ GI transition fitting up to the Domestic customers "Appliance /stove / oven for satisfactory completion to the owner/owner's representative.
- Supply and Installation of powder coated GI pipes of ½" dia. between transition fittings to customers kitchen appliances including NPT threading of GI pipes, supply of proper seal outs for threads to join fittings such as elbows, tees, connectors, appliances & isolation valves etc., as per laid procedures and specifications including clamping and sealing etc. The powder coated GI pipe shall be painted after the testing of the GI installation wherever touching is required to eliminate any coating defects during installation. Where all GI fittings shall be fully painted after testing as per defined Specification.
- Supply of clamps for fixing pipes, Meters wherever required, painting of pipes and fittings. Providing consumables grout material, repair/restoration of walls/floors changes for the pipes including the materials required for conversions and tools and tackles etc. shall be completed as per specification.
- Submit certified copies of RFC card to Projects & O&M after uploading the details in

HOGPL ERP Vendor Portal as prescribed by Client.

- Cleaning, flushing, pneumatic testing and commissioning to the GI pipe & fittings, meters, valves etc. as per specification and hand over the same to Owner/Customer to the entire satisfaction of EIC/CONSULTANT.
- Dismantling of scaffolding/temporary structures and cleaning of site & restore the site as per its original condition.
- Restoration of walls, flooring and other damages while executing the above ground installation up to satisfaction of properly owner.
- Preparation and submission of above ground installation card for each house indicating the laid GI pipe including fittings, mentioned the reasons, if connecting, testing, etc. is not provided to the customers and deviation statements on completion /commissioning of work.
- Any other activities not mentioned/covered explicitly above, but otherwise required for satisfactory completion/operation/safety/statutory/maintenance of the works in new & existing gas charged areas shall also be covered under the Scope of work and has to be completed by the Contractor within specified schedule at no extra cost to Owner.
- Following activities are also in Contractor's Scope:
 - Receive Customer's request and complaints logged on HOGPL's portal/Offline.
 - Carry out joint technical feasibility survey for requests received.
 - Attend and resolve customer complaints within defined TAT.
 - Maintain and update the request and complaint status in HOGPL's portal.
 - Contractor should execute GI Installation works with following priority
 - Online Domestic connections: Gas Supply is available in the locality and pipeline is available just outside kitchen – 20 days from date of receipt of registration
 - Fresh Riser Installation in Domestic Connections: Gas available in an apartment/complex but pipeline installation pending in the concerned Tower (for building with less than G+14 floors) Or In case of Kothi /Bungalow, where gas pipeline is available outside the premises (where service line is already installed)– TAT-40 days
 - Underground gas pipeline available across road : i.e. Where service line has to be laid (Laying of service line up to 20m)–TAT-60 days
 - Connection rates in project areas; in High Rise segment (TAT-90 Days) & low-rise segment (TAT-75 Days)
- Maintain new connection tracking on HOGPL's portal. Providing adequate manpower, minimum 2 no's each such as data entry operator, customer care executive etc. for data logging like new connection request & GI tracking, attending complaints, day to day interaction with customers and residents so that work can be executed within defined time period (TAT) Turn Around Time.
- Providing adequate manpower for carrying out laying for PNG installation for emergency

cases as and when required. The TAT period for carrying out such emergency cases are defined in tender document.

- Printable material i.e. RFC book, sticker & safety Guidelines shall be provided by owner. All other printable materials like feasibility report etc. shall be in contractor's scope.
- All size of GI pipes shall be powder coated before installation and it is in the scope of contractors. Contractor shall submit powder coating procedure to EIC/ Consultants before powder coating of pipes.

4.0 MATERIAL, MANPOWER EQUIPMENT AND MACHINERY

4.1 Material to be supplied as a free issue material

Domestic meter & Meter Regulator shall be supplied as a free issue material to the contractor. The contractor shall not use any other material from any other source of supply other than owner's supplied material without any written approval from EIC.

4.2 Material/Equipment & machinery to be supplied by contractor

Contractor shall procure/ purchase GI fittings, isolation valve, appliance valves, Brass fittings, and Reinforced rubber hose with all other materials which is required to satisfactory completion/safety/statutory of the works as per tender at no extra cost to Owner. The HOGPL logo shall be marked on the material supplied by contractor. The contractor shall take approval from owner/owner representative for marking on the material to be procured by contractor before placement of order.

The Contractor shall provide labour, tools (such as Hammer Drill, Piston Drill, Pipe Cutters, Dies for threading, Pipe wrenches, spanners, conversion kits, solder torch, copper tube Cutters, tube benders, lacquering, thinner etc.) in specified numbers, all types of clamps, Plant and equipment necessary for the proper execution of the work. This will include but not limited to list of specialized tools and tackles indicated in Annexure #1.

Special tools shall be required at site for carrying out drilling work in walls other than Brick or RCC (Ex. Granite, Marble, Wooden, Glass Cutting etc.)

The contractor has to ensure the availability of DG sets for continuous power supply. In case the power supply is availed at the site from societies, individual residents, contractor shall settle the claims raised by the electricity providers without any cost implication to OWNER. In case contractor doesn't settle the claims for using the electricity from societies/individual residents, on demand by the providers, OWNER will settle the claims and the same will be deducted from the contractor's bills. The progress of work shall not hamper due to non-availability of power supply.

The contractor has to submit the valid calibration certificate for Pressure gauges.

Contractor shall submit the manufacturer test certificate slab test certificate for all items procured by him for approval before commencing the execution.

No hiring of equipment's, tools and tackles by the contractors is allowed at the site. In case any contractor is found not in possession of enlisted required tools and tackles, penalty will be levied as per the SCC which shall be deducted from the running bills.

4.3 Plant and Equipment

All vehicular type machinery shall be in good working condition and shall not cause spillage of oil or grease. To avoid damage to paved surfaces, the contractor will provide pads of timber or thick rubber under the hydraulic feet or outriggers of machinery.

4.4 Sealant, Grout

The contractor shall be responsible to arrange the supply of any consumable sealant or ready mix grout material required for restoration of holes. The sealant/grout supplied by the contractor shall be compatible with the area to be restored/ rectified. No separate payment for the supply of sealant and grout shall be made to the contractor.

4.5 Clamps, Rawal Plugs, Screws and etc.

The Clamps, Brackets for meter, Rawal Plugs, SS-304 Screws (2" length), Nozzles, etc. shall be approved lot wise by EIC prior to installation. Re-drilling of existing appliance (burners) nozzles is strictly not permitted. The quality of materials procured will be got approved and will be as directed by EIC.

The indicative sketch of the Brackets for Meter, and GI Pipe Clamps is enclosed with the tender. No separate payment for the supply of Meter Brackets and GI/Copper clamps shall be made to the contractor.

4.6 Consumable Items

- Special Consumables such as Teflon Tapes, solder wire, flux, lacquer, thinner shall be supplied by the contractor and are included in installation rates.
- These consumables shall be of reputed make companies and required grades/class

4.7 Other Materials

The contractor shall supply the following items where required:

- All materials required for work, NPT threading, copper pipe jointing, testing etc.
- All signs, barricades, lights and protective equipment.
- All material required for working at higher floor levels (i.e., scaffolding, Ladder, Safety Belts, Self-Locking Safety Harness Belts etc.).
- Special consumable such as grease for maintenance of domestic appliances, all paints for painting of GI Pipes, Consumables such as Teflon Tapes, Solder- wire, Flux, Lacquer, Thinner, Petrol, Diesel, Fuels and Oils required are to be supplied by the contractor and are included for within the rates.
- All minor items not expressly mentioned in the contract but which are necessary for the satisfactory completion and performance of the work under this contract.

4.8 Acquisition, Receipt and Storage of Materials

The Contractor shall collect Domestic meter, Regulators, Isolation and Appliance Valve from Owner's designated stores in between the hours to be advised by the EIC.

The contractor shall carry out assessment of material required for GI installation in allocated area. After approval from Owner, contractor shall place order for purchasing of GI

Pipes & fittings, Copper pipes & fittings, Brass Fittings, and Reinforced Rubber hose (Technical specifications attached in the tender document) to anyone of approved vendors as per the list attached in the tender document. The contractor shall also ensure that the QCT for these materials shall be approved before the start of production activity. Once QCT is approved, contractor shall forward inspection call to the Owner depending upon the material requirement at the site. The inspection of these materials shall be carried out by Owner appointed third party inspection agency. It is contractor's responsibility for document submission, arranging dispatch clearance, handling, loading, transportation and unloading of these materials at their own respective store.

Any other activity not mentioned/covered, explicitly, but otherwise required for satisfactory completion/operation/safety/statutory/maintenance of works shall also be covered under scope of work and has to be completed by contractor within specified schedule at no extra cost to Owner. The Contractor shall carry free issue material in such a manner as to preclude damage using transportation and handling.

The Contractor shall physically examine all materials at the time of acceptance the material in store and notify the EIC immediately of any damage or defect noticed by the Contractor. The HOGPL representative shall duly note any damage or defect in a site instruction book and both parties shall counter sign the entry.

Any damage not so recorded will be deemed not to have existed at the time of acceptance of material in store by the Contractor and the cost of repair or replacement or rectification shall be borne by the Contractor.

All materials shall be stored in contractor's stores near site in such a manner so as to prevent any damage to the materials from scratching, gouging, indentation, excessive heat or by contact with any sharp objects or chemicals.

The Contractor shall be required to submit inventory details of materials every month.

The Contractor shall maintain log book at their respective stores stating issue and availability of free issue material at a given day. Further, it is mandatory that the contractor is required to undertake and submit inventory details of free issue and purchased materials on monthly basis to Owner/ Owner's representative as per the approved format of the owner. The inventory details shall be in correlation with the Daily progress chart and material reconciliation sheet.

Material reconciliation indicating issue of material, consumptions and defective material shall be submitted on every three months basis.

5.0 ISSUE OF WORK INSTRUCTIONS

- The contractor will be required to carry out GI installation in the areas where MDPE laying is under progress. However, testing of GI installation shall be done in conjunction with laying of MDPE Service Lines to respective premises. A general scheme of distribution to domestic consumer is indicated in enclosed drawing No: 14588-20-05-09 for reference. It may vary in case of individual and multi storied flats.
- All skilled personnel like jointers, conversion technicians will be approved and certified by EIC. The technicians who will carry out joining of copper material and conversions will undergo a test by Owner. Those who clear the test will be issued identity cards duly signed by EIC. These technicians shall be only authorized to take

up respective jobs. In case it is found that contractor personnel other than authorized are carrying out these works, applicable penalty will be levied to the contractor as per contract.

- The rates to be quoted by contractor shall be inclusive of all preparatory/bye works, platform materials, labour, supervision, tools, taxes, duties, levies, salaries, wages, overheads, profits, escalations, fluctuations in exchange rates and no change in the rates shall be admissible during tenancy of the contract.
- The schedule of items of GI installations have been described in brief and shall be held to be completed in all respect including safety requirements as per Standard Specification of HSE, tests, inspection, QA/QC works, enabling and sundry works. The payment shall be made against completed and measured works only. No extra works whatsoever shall be considered in execution of these items.

6.0 PROGRESS OF WORK

The contractor shall proceed with the work under the contract with due expedition and without delay. Contractor shall assess the material requirement of the allotted area and submit the schedule plan for execution & purchasing before start of actual work.

The EIC may direct in what order and at what time the various stages or parts of the work under the contract shall be performed. Weekly progress reports shall be submitted in the formats approved by Owner, indicating broadly the laying, testing, RFC, conversions and extra piping.

7.0 WORK SHEETS

- The quantities of GI pipe and other details will be checked by Owner's site engineer and the same shall be incorporated in RFC cards, signed & dated as certified, on site. The cards will then be approved by the EIC.
- Measurement sheets shall be prepared based on the RFC cards and checked and certified by the site engineers for billing purpose.
- If measurement sheets submitted are illegible, incomplete or incorrectly booked they will be returned to the contractor.

8.0 PERMISSIONS / APPROVALS

- Contractor shall be responsible for obtaining permissions from society management, RWA, individual residents and any other concerned authority, if required, for completion of the work. Contractor must take the prior appointment from the residents for carrying out the work.
- The prospective bidder shall work in close consultation/coordination with the EIC.
- The prospective bidder shall not sign/execute any agreement and/or undertaking on any such documents which amounts to be under taken by Owner. The same shall only be signed and executed by Owner; however, the prospective bidder shall also liaison and coordinates for the same.
- The necessary coordination, liaison and arrangements for inspection and approval shall be the contractor's responsibility. Inspection and acceptance of the work by authority shall not relieve the contractor from any of these responsibilities under

this contract. The contractor shall plan the execution of work in such a manner so that all the registered customers are attended in phased manner. However, it is the contractor's responsibility to fix a firm appointment with the consumer for carrying out the work.

- A log book/job card for such appointments with Consumer/any other agencies shall be maintained and the schedule/appointment once taken shall be adhered to by the contractor. PMC/EIC shall review the records every week. The contractor shall submit the detailed list of RFC/Conversions and balance work on Registrations at least once a week as per approved format.
- The contractor is also required to obtain a "Labour License" from the Assistant Labour Commissioner of respective Administration/Central Govt.
- It will be the contractor's responsibility to familiarize himself and comply with, any other local rules, regulations or statutory requirements applicable to the work.
- The contractor has to take responsibility of the action of supervisors, plumbers and helpers provided by him.

9.0 REFERENCE SPECIFICATION, CODES AND STANDARDS

The contractor shall carry out the work in accordance with this specification, Owner's Engineering Standards: ASME B31.8 - Gas Transmission and Distribution Piping Systems; Oil Indian Safety Directorate Norms (OISD), the American Gas Association Document - Purging Principles and Practice and PNGRB Guidelines.

If the contractor find any discrepancy, ambiguity or conflict in between any of the Standards and the contract documents, then this should be promptly referred to the Engineer -in-Charge (EIC) for his decision, which shall be considered binding on the contractor.

10.0 RIGHT-OF-USE SERVEY AND MARKING

The route of the pipeline to be installed shall be decided with consent of the consumer and Site Engineer/EIC. Contractor must ensure that the persons/workers/supervisors/ working at site shall have proper identity cards prior to entering the premises of the consumer.

No temporary or permanent deposit of any kind of material resulting from the work shall be permitted in the approach or any other position, which might hinder the passage and/ or natural water drainage, or any area where there is objection from consumer.

The contractor shall obtain necessary permissions from land Owners and tenants and shall be responsible for all damages caused by the construction and use of such approaches, pavements, gardens, rooms, walls, roof etc., at no extra cost to Owner.

Owner/Consultant and the contractor at each premises or housing colony to be supplied with gas will conduct a joint survey. The survey record will note Customer details, the potential gas supply points and proposed meter positions and estimates of material quantities. The contractor's representatives will make as sketch of the agreed pipe routes, if necessary.

The contractor will be responsible for contacting the Customer and making the necessary arrangements for access and appointments to carry out the work. Owner will not be responsible for any time lost due to failed appointments or disputes with Customer.

The contractor shall confine its operations within limits of the Right in use. The contractor shall restore any damage to property outside ROU.

The contractor shall also carry-out all necessary preparatory work if needed to permit the passage of men and equipment. Lights, Curbs, signs shall be provided wherever and/or required by the Owner necessary to protect the public.

11.0 PROTECTION OF STRUCTURES AND UTILITIES

The contractor shall at his own cost, support and protect all buildings, walls, fences or other structures and all utilities and property which may, unless so protected, be damaged as a result of the execution of the works. He shall also comply with the requirements in the specification relating to protective measures applicable to particular operations or kind of work.

While painting, contractor must take care of the consumer premises while carrying out the job such as spillage on floor, walls, ceilings, sun shades etc. If the same does occur, the contractor has to immediately make things to original.

12.0 POWDER COATED GI ABOVE GROUND SERVICE PIPE

The powder coated GI service pipe installation work includes all work necessary to connect from the PE/GI transition fitting on the down-stream of the PE service, to the Customers appliance, including the installation of regulator, valves, fittings, meters, clamps etc. The contractor shall be required to provide all equipment, tools and materials necessary to execute the work in an efficient and effective manner. Along with ladders, scaffolding pipe, dies, tripods, vices, fittings and Teflon tape, drills for concrete and other masonry, drills for timber, Granite, Marble Stones and laminated surfaces inside Customers property, bending tools, clamps, sleeves to facilitate the pipe passing through floors and walls, paint for marking etc.

All powder coated GI risers at the outside of buildings shall be fully supported to carry the weight of piping. A flanged foot or similar device, capable of supporting the total weight of the riser, shall support risers. The riser shall be installed in a vertical line from its point of support to its highest point with a minimum of changes in direction. The threading of GI pipe shall be NPT and conforming to ANSI B I 20.1

Contractor has to supply different types/sizes of approved powder coated clamps (Mild Steel) for fixing GI pipes suiting to the site conditions. The contractor shall get approval from EIC for every fresh lot of the clamps, brackets, regulator boxes and other consumables, prior to start of installation. The detailed cross sectional of GI Pipe Clamps/Meter brackets are as per Drawing No. 14588-20-05-05;

All riser and lateral pipe shall be clamped to the building at intervals not exceeding 1.5 mtrs. Maximum distance between clamps shall be 1.0 - 1.5m when pipe goes to the straight, if any tee or fittings lies in between the pipe then clamp shall be placed 150 mm far away from center line of fittings at every sides. However, the same may be changed as per site conditions/as directed by EIC. Minimum gap between pipe & wall shall be 25 mm. The joints/ fittings of the GI installation shall be painted only after carrying out testing of the installation.

Where pipe passes through the balcony and the surface is slightly elevated around the service pipe or its surrounding sleeve to prevent the accumulation of water at that point. Where a

short piece of sleeve is used around the gas pipe, the sleeve should be embedded in the concrete with a mix of mortar and the void between the pipe and sleeve filled with a suitable sealant. The sealant should be beveled such as to prevent an accumulation of water. Supply of clamps for all sizes of the GI pipes is in contractor's scope. Contractor has to take prior approval for design/types of clamps, paintings etc. Pipe shall preferably be entered into building above ground and remain in a ventilated location. The location for entry shall be such that it can be easily routed to the usage points by the shortest practicable route.

12.1 NON LMC

Non LMC GI Pipe shall be defined as the GI pipe installed from transition fitting to lateral isolation valves.

- **Riser Isolation Valve (RIV) piece:** Powder coated GI pipe of 1/2" dia installed of length 1.5m from transition fitting up to riser isolation valve (RIV), Its length may vary as per site situation subject to prior approval from Site In-Charge or as per instruction of EIC. The Laying of GI Pipe from the transition fittings to RIV shall be payable in the numbers as per relevant SOR if applicable.
- **Riser for Bungalow /Apartments having floors up to G+3:** Powder coated GI riser pipe of 1/2" dia shall be installed from RIV piece to lateral isolation valve for G+3 Apt and Individual kothi /Bungalow. Refer Drawing No. 14588-20-05-02.
- **Riser for Bungalow/Apartments having floors more than G+3:** Powder coated GI riser pipe of 3/4" dia shall be installed from regular isolation valve to lateral isolation valve for Apt and Individual Kothi/Bungalow having floors more than G+3. Drawing No. 14588-20-05-03

12.2 LMC

LMC GI pipe shall be defined as the GI pipe installed from lateral isolation valve to appliance valve.

- **PNG CONNECTIONS IN PROJECT AREA**

Supply and installations from riser (lateral isolation valve) up to appliance valve, supply of steel reinforced rubber hose with clamps and conversion of each burner.

- **PNG CONNECTIONS IN O&M AREA (ON EXISTING RISER)**

Supply and installations from existing riser after lateral isolation valve up to appliance along with installation of meter , supply of steel reinforced rubber hose with clamps and conversion of burner.

The GI/brass fittings shall not be counted separately & shall be measured along with GI & Cu pipe.

Except Meter and Regulator, Contractor shall procure all other materials (i.e. Pipe, fittings, clamps, valves etc.) as per attached specification for installation and to the entire satisfaction of EIC/consultant.

The contractor shall also ensure that gas supply shall not be provided to the customer in any Concealed Piping.

The Copper service pipe installation work includes all work necessary to connect downstream of the meter to the Customers appliances. The contractor shall be required to provide all equipment, tools and materials necessary to execute the work in an efficient and effective manner. Along with these, he will be required to provide ladders, scaffolding pipe, drills for concrete and other masonry, special drills for timber, Granite, Marble Stones and laminated surfaces inside Customers property, bending tools, sleeves to facilitate the pipe passing through floors and walls, etc. Copper pipes & fittings shall be provided by Contractor.

During installation the Copper pipe is to be cut to proper length with tube Cutter, the burrs removed with a file, cleaning of outside surface of pipe & inside surface of fitting, applying flux to the tube and fitting around the outer/inner ends, inserting the tube in to the fitting, applying heat to the assembled joints using conventional blow torch to melt solder wire. Contractor shall submit the joining procedure of Cu pipe & Fitting to the approval or as per the instructions of EIC.

Contractor has to supply different types/sizes of approved clamps (PE 80/PVC) for fixing Copper pipes suiting to the site conditions Contractor has to take prior approval of EIC for quality of the clamps, solder, flux, lacquer, thinner etc. The approval shall be taken for every fresh lot of clamps from EIC before installation at site.

All copper piping shall be clamped to the walls at intervals not exceeding 500 mm. The solder wire shall be of reputed company of diameter size 3.25mm, Lead free as per BS 29453:1994 (Soft solder alloys) and supplied in coils. The detail specification is attached in tender for reference. Solders for use with copper tube & fittings generally melt within the temperature range 180°C- 250°C. The contractor has to furnish the certificate of confirmation of standards before start of work.

- **Installation of Meter**

Installation of domestic meters with associated inlet and outlet connections (GI/Brass fittings), on the wall with approved powder coated meter brackets and angles in new areas ensure a clear gap between meter and wall.

The contractor shall supply approved powder coated meter brackets and angle brackets. A sketch of the brackets is referred from the enclosed drawing for reference. It is required that one sample of each type of bracket is approved before the work is started.

Firmly secure the meters on the wall with good quality Rawal Plugs, screws etc. In case the Rawal Plugs are not holding then wooden blocks or other fixing arrangements like cement etc. to be used for proper grouting.

Note : Installation of meter should be done at height of approx. 04 to 06 feet.

The Meter installation will be preferred in open/ventilated space so as to prevent Gas accumulation and easy dispensation of gas to atmosphere in case of any smell/leakage of gas. The Meter installations will not be provided in any fixed enclosures, cabinets (below or above the slab) or confined space in the customer premises.

The Contractor shall ensure that GI installations and rubber hoses shall not be exposed to direct heat of Gas burners. The installation should have minimum

clearance of about 1 meter from electric point mains & switches. Minimum distance between Appliance Valve & Gas Burners shall be 0.3 Meters. The isolation valve shall be installed after entering the customer premises/kitchen but before the meter installation.

The above activities along with restoration of the area to original shall be carried out to the complete satisfaction of consumer and EIC.

Powder Coating /Painting of GI Pipes

The entire lengths of the pipeline along with fittings are to be painted / powder coated after proper surface preparation as follows:

(a) **Painted (for scratched powder coated pipes and fitting only):**

- One coat of Primer Application (Appropriate Zinc based primer)
- Two coats of synthetic enamel paint- canary yellow of minimum of 30 microns per coat of reputed make like Asian, Berger, and Nerolac. (No other make shall be used for painting).

All painting materials including primers and thinners brought to site by contractor for application shall be procured directly from manufacturers/dealers as per specifications and shall be accompanied by manufacturer's test certificates. The contractor shall ensure that smooth finish is attained after carrying out painting.

Engineer-in-Charge at his discretion may call for test for paint formulations. Contractor shall arrange to have such tests performed including batch wise test of wet paints for physical and chemical analysis. All costs there shall be borne by the contractor.

The painting work shall be subject to inspection and certification by Engineer-in-Charge at all times. Painting of GI pipe shall be paid with installation of GI pipes.

(b) **Powder coating (refer attached Specification for powder coating)**

Contractor will be required to install powder coated GI pipes shall submit detailed procedure of powder coating for approval to Consultant prior to supply of GI pipes. After installation of the entire piping system, final touching shall be done to the satisfaction of EIC.

13.0 TESTING OF GI / COPPER INSTALLATION

- The installation from PE/GI transition fitting up to regulator shall be tested at the pressure of 6.0bar (g).
- The testing of GI riser pipe up to regulator shall be done with the isolation valve in open condition and open end plugged.
- The GI/Copper installation from regulator outlet to appliance valve (except meter) shall be tested at a pressure of 2.0 bar (g) for a holding period of 2 hour with no pressure drop. All the joints in the installation shall be checked with soap solution.
- The meter shall be removed while carrying out the testing at 2 bar (g) and joints of

the meter shall be tested on line with soap solution after completion of the work. For testing proper test ends shall be made along with gauges and subsequently approved by EIC. For the installation to be tested by manometer or diaphragm gauge the meter shall not be dismantled/removed and testing shall be carried out at 100 m bar with holding period of 15 min with no pressure drop.

- The contractor shall supply the Calibrated Pressure Gauges/ Manometer/Diaphragm Gauges of suitable range for testing of GI/Copper Installations ranging from 0-4 bars/0-150 m bar/0-250 m bar respectively. The calibration certificate shall be submitted before the start of the execution work.
- The pressure gauges shall be calibrated from time-to-time as desired by EIC but positively once in every six months.
- The details of testing shall be properly recorded in the GI/Copper cards.
- The ends/joints shall be painted only after carrying out testing of the installation. Powder coating to GI pipes shall be carried out in factory/ shop, and repair/ touching shall be carried out at site.

14.0 INSPECTION

The contractor to the entire satisfaction of EIC before proceeding further shall rectify any defect noticed during the various stages of inspection. Irrespective of the inspection, repair and approval at intermediate stages of work, contractor shall be responsible for making good any defects found during final inspection/guarantee period/defect liability period as defined in general condition of contract.

15.0 PURGING & COMMISSIONING

The rate for purging & commissioning shall be included in the GI installations.

Care shall be taken to ensure that the outlet is so located that vent gas cannot drift into buildings.

The commissioning of the GI installation should be performed as follows:

- Ensure the method of purging is such that no pockets of air are left in any part of the Customer's piping.
- Ensure the area is well ventilated, and free from ignition sources.
- Continue to purge until gas is available at other appliances; Check availability of gas using Methane- detector
- Internal piping i.e. Meter Inlet, Diaphragm Meter & copper pipe shall be tested pneumatically & with soap solution from inside of each domestic connection

16.0 RESTORATION

Contractor has to restore the area wherever he has carried out drilling, clamping etc. to its original condition to the satisfaction of the consumer and to ensure no passage to the premises and seepage. If the work was carried out in Govt. Flats (CPWD/NDMC/Institutional areas), contractor has to restore the area according to CPWD specifications and obtain a NOC/Clearance certificate from the concerned

authorities maintaining the flats, after completion of the work.

The restored slabs or brickwork should match the surrounding surface levels. Joint widths should match the existing conditions and be filled with a dry or wet mix of mortar.

Wherever any items of the consumer is damaged/broken during working, the same will be made good or replace to the total satisfaction of the consumer.

The contractor will be responsible for the maintenance of all restoration carried out, for the duration of the contract guarantee period.

The contractor is to ensure the restoration work is properly supervised, and that the material used is suitable for the purpose. Wherever the required standards are not achieved the contractor will be required to replace the defective reinstatement work.

Note that Payment for GI/Copper installation will be released only after satisfactory restoration and clearing of the sites of all surplus materials etc.

16.0 SUBMISSION OF FINAL RECORDS

Contractor shall submit three sets each of the following documents in hard & soft copy:

- Total list of houses in the area allotted to him giving details of connections provided & reasons where connection could not be given completed.
- The details recorded in RFC cards of every domestic house.
- Details of houses where piping done along with materials used.
- Total material consumption report.
- Material reconciliation with respect to the materials issued.
- Test reports & calibration certificates of gauges etc.
- Any other documents/records required.
- Extra Piping details

17.0 COMPLIANCE TO HEALTH, SAFETY & ENVIRONMENT (HSE) FOR LOW RISE GI

Scope include use of Fall arrestor, Ascenders / descenders, PPE, Barricades/ Warning Boards (03 No's) connected with warning board & Caution tapes (Refer drawing no. 14588-20-05-32, 26) in areas where piping work is in progress, Use of Safety shoes, Walky talky, Hand gloves, Reflective jackets, Hard hats (helmets), eye and ear safety equipment, Fire extinguishers and as per the detailed scope of work in tender specifications. Contractor shall also prepare and submit duly certified Safety check list signed by TPIA/PMC. In case of non-compliance, penalty shall be applicable as per SCC clause.

This set-up is applicable up to 4th (G+4) floor and full body safety harness with accessories shall be of KARAM or equivalent make.

ANNEXURE 1

TOOLS & EQUIPMENT TO BE PROVIDED BY CONTRACTOR FOR GI/COPPER WORK

S. No.	Hand Tools Description	Per Technician	Per Team
1	Pipe Wrench 250 mm	1	4
2	Pipe Wrench 350 mm	1	4
3	Pipe Wrench 450 mm	-	2
4	Adjustable Spanner 50 mm	-	4
5	Adjustable Spanner 150 mm	1	2
6	Adjustable Spanner 250 mm	1	2
7	Set of combination spanner 3/16"- 1 1/4"AF	1	1
8	Set of combination spanners 5mm- 30mm	1	1
9	Large tool boxes	1	2
10	Set flat - headed screw drivers	1	2
11	Set Philips screw drivers	1	2
12	Small hammer	1	2
13	Combination pliers/mole grips	1	2
14	Set of files	1	2
15	Drill bits for 1" pipe	-	2
16	Stocks and dies for NPT threading 1/2", 3/4", GI pipe	-	3
17	Blowtorch	-	1
18	Hand drill 3/8" chuck	-	2
19	Portable electric drill 240v, heavy duty	-	2
20	Spare blades	4	4

21	Batter Powered torches	2	2
22	Measuring Tape 30m	1	2
23	Wire Brush	1	2
24	Portable Pipe vice & tripod	-	2
25	Set steel twist drills 0.5-2.0mm (for appliance conversion)	-	1
26	Set steel twist drill 1mm-10mm	-	2
27	Set masonry drills 1mm-10mm	1	2
28	Graphite based grease	As required	As required
29	Lubricating Oil	As required	As required
30	Hand Cleaner	As required	As required
31	GI Pipe Cutters ½" Gas Detection Equipment Power Generator 2.5 KVA Pressure Gauge (0-10 bar) Pressure Gauge (0-4 bar) Diaphragm Gauge (0-400m bar) Manometer (0-150m bar)	-	2
		As required	-
		As required	-
		2	4
		2	8
		1	2
32	Automatic Thread Cutting Machine	-	As required
33	GI Pipe Cutter	-	2

ELECTROFUSION FOR PE PIPES & FITTINGS
STANDARD SPECIFICATION

CONTENTS

1.0	ELECTRO FUSION FOR PE PIPE	3
1.1	ELECTRO FUSION FITTING JOINTING	3
1.2	ELECTRO FUSION JOINTING METHOD / PROCEDURE	4
1.3	RECORDS.....	5
1.4	TRAINING	5
1.5	ELECTRO FUSION SADDLE JOINTING	5
1.6	ELECTRO FUSION SADDLE JOINTING METHOD/ PROCEDURE	6
1.7	RECORDS.....	7
1.8	TRAINING	7
1.9	STOPPING THE GAS FLOW	7
1.10	SQUEEZE-OFF	7
1.11	BENDING-BACK.....	8

1.0 ELECTRO FUSION FOR PE PIPE

1.1 ELECTRO FUSION FITTING JOINTING

1.1.1 For electro fusion fitting jointing, an electrical resistance element is incorporated in the socket of the fitting which, when connected to an appropriate power supply, melts and fuses the materials of the pipe and fitting together.

1.1.2 The effectiveness of this technique depends on attention to the preparation of the jointing surfaces, in particular the removal of the oxidized surface of the pipe over the socket depth and ensuring the jointing surfaces area clean. Also, the pipe should be checked for ovality. If ovality causes a gap between concentrically located pipe and the fitting to exceed 1% of the pipe OD, the pipe must be re-rounded to ensure correct welding. If the gap still exceeds 1% of the pipe OD after re-rounding then a check should be made of the pipe OD dimensions to determine if it meets specification.

Max gap 1% of pipe OD

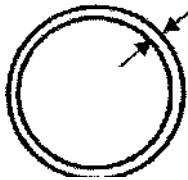

Concentrically Located

Max gap 2% of pipe OD

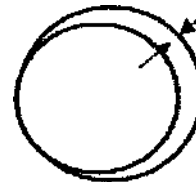

Eccentrically Located

1.1.3 The maximum gap between eccentrically located pipe and fitting i.e. Pipe touching fitting at one point, must not exceed 2% of the pipe OD.

1.1.4 Sometimes coiled pipes may be too oval to fit into couplers, or the end of the pipe may make the alignment of the ends impossible. In such circumstances the use of a mechanical pipe straightener or rounding tool is necessary.

1.1.5 The equipment and procedures following relate to fittings with center stops. If fittings without center stops are used, the maximum insertion depth must be clearly marked on the pipe ends prior to joining (felt tip pen).

Equipment

- The control box input supply to be from a nominal 240V generator, which is normally of approximately 5kVA capacity. The nominal output of the generator is to be 240V +15%, I 0% between no load and full load. Control boxes are to include safety devices to prevent excessive voltages being present at the control box output. The safety device shall operate in less than 0.5s.

Note that extension leads are not to be used on the control box outlet connections.

WARNING: Control boxes are not intrinsically safe and must therefore not be taken into the trench.

- A mechanical pipe surface preparation tool is to be used before fusion is attempted. The tool is to be capable of removing the oxidized surface of the pipe in excess of the insertion depth. The tool is to remove a layer of surface material 0.20.4 mm thick from the outer surface of the pipe preferably in a continuous strip of swarf

over that length and round of the pipe.

- Pipe clamps for restraining, aligning and re-rounding the pipes in the fusion process are to be used.
- Pipe cutters with saw and saw guide.
- Protection against adverse weather conditions.

1.2 ELECTRO FUSION JOINTING METHOD / PROCEDURE

Preparation

- Ensure there is sufficient space to permit access to the jointing area. In a trench, a minimum clearance of 150 mm is required.
- Check that the pipe ends to be jointed are cut square to the axis of the pipe and any burrs removed.
- Wipe pipe ends using clean lint-free material to remove traces of dirt or mud, etc...
- Mark the area over which the oxidized pipe surface is to be removed, i.e. In excess of the insertion depth, on each pipe to be joined by placing the socket of the bagged fitting alongside the pipe end. Trace a line round the circumference at the appropriate distance from the end of the pipe using a felt tip pen or similar.

Note that the fitting should not be removed from the packaging at this stage.

- Connect the electro fusion control box input leads to the generator.
- Check that the reset stop button, if fitted on the control box, is in the correct mode.
- Using the pipe end preparation tool, remove the entire surface of the pipe uniformly, preferably in continuous swarf over the area identified, i.e. In excess of the insertion depth.
- A mechanical scraper could be used however; there is a considerable risk that the end preparation will not be adequate with the use of such a tool.

Note that the prepared pipe surface should not be touched by hand.

- Remove the fitting from its packing and clean the scraped area of the pipe surface and the bore of the fitting with a disposable wipe impregnated with Iso-propanol I Acetone. Ensure the prepared surfaces are completely dry before proceeding.

Note that while Iso-propanol is a suitable cleaner, its use is subject to local Health and Safety Regulations.

- Check that the pipe clamps are of the correct size for the pipes to be jointed.
- Insert the pipe ends into the fitting so that they are in contact with the center stop.
- Using the pipe clamps, secure the pipes so that they cannot move during the fusion cycle. Check that the pipe ends and the fitting are correctly aligned.
- Check that there is sufficient fuel for the generator to finish the joint. Start the generator and check that it is functioning correctly.
- Switch on the control box.
- Connect the control box output leads to the fitting terminals and check that they have been fully inserted.

If required by the control box enter the fusion jointing time into the control box timer. The jointing time is indicated on the fitting. Check the correct time is shown on the control box display.

Note 1: Automatic control boxes are available which obviate the need to enter the fusion time.

Note 2: Gloves and goggles should be worn during the Fusion process.

- Press the start button on the control box and check that the heating cycle is proceeding as indicated on the display.
- On completion of the heating cycle, the melt indicators should have risen. If there is no apparent move in the melt indicators, the joint should be cut out and a fresh joint made (See note 3 below).
- If a satisfactory joint has been made, the joint is to be left in the clamps for the cooling time specified on the fitting or the automatic control box.

Note 3: If the fusion cycle terminates before completion of the countdown, check for faults as indicated by the control box warning lights and check that there is adequate fuel in the generator. DO NOT attempt a second fusion cycle within one hour of cooling of joint at Ambient Temperature of the first attempt.

1.3 RECORDS

Records of appropriate servicing and calibration shall be kept.

1.4 TRAINING

It is necessary that operators, inspection and supervisory personnel acquire the skills of electro fusion fitting fusion. The necessary training should be carried out by a qualified instructor with the objective of enabling participants to;

- Understand the principles of electro fusion fitting jointing.
- Identify pipe and appropriate fitting markings.
- Carry out pre-jointing machine and equipment checks.
- Make satisfactory electro fusion fitting joints from pipes and fittings of different sizes.
- Inspect for and identify joints of acceptable quality.

Note that some form of assessment and certification should be associated with the training. The certificate should detail the pipe and fitting size range. And the equipment used. A register of successful participants should be kept.

1.5 ELECTRO FUSION SADDLE JOINTING

- With electro fusion saddle jointing, an electrical resistance element is incorporated in the base of the saddle which, when connected to the appropriate power supply, melts and fuses the material of the fitting and the pipe together.
- The success of the technique depends on effective preparation of the jointing surfaces, in particular the removal of the oxidized surface of the pipe over the area equivalent to the area of the saddle base, and cleaning of the pipe surfaces.
- Methods of holding the tapping tee saddle during the fusion cycle are used namely, top loading and under clamping. The general parameters are similar. In some cases, if

the manufacturer's procedure for holding the fitting is provided, then the same should be followed during the fusion cycle.

1.6 ELECTRO FUSION SADDLE JOINTING METHOD/ PROCEDURE

- Expose the pipe onto which the tapping tee is to be assembled, ensuring there is sufficient clear space around the pipe. In a trench, a minimum clearance of 150 mm is required.
- Clean the pipe over the general area on which the saddle is to be assembled using clean, disposable lint-free material.
- Without removing the fitting from its packaging, place it over the required position on the main. Mark the pipe surface all around and clear of the saddle base area using a felt tip pen or similar.
- Remove the surface of the pipe to a depth of 0.2 to 0.4 mm over the full area marked using a suitable tool. Remove the swarf.
- Connect the electro fusion control box input leads to the generator.

Check that the reset stop button, if fitted on the control box, is in the correct mode.

- Remove the two halves of fitting from its packing and clean the scraped area of the pipe surface and the bore of the fitting with a disposable wipe impregnated with Iso-propanol / Acetone. Ensure the prepared surfaces are completely dry before proceeding.

Note again that while Iso-propanol is a suitable cleaner, its use is subject to local Health and Safety Regulations.

- Position the fitting base onto the prepared pipe surface, and bring the lower saddle into position then gradually and evenly tighten the nuts until the upper saddle makes firm contact with the scraped pipe.
- Check that there is sufficient fuel for the generator to complete the joint. Start the generator and check that it is functioning correctly.
- Switch on the control box if applicable.
- Connect the control box output leads to the fitting terminals and check that they have been fully inserted.
- If required by the control box, enter the fusion jointing time into the control box timer. The jointing time is indicated on the fitting. Check the correct time is shown on the control box display.

Note 1: Automatic control boxes are available which obviate the need to enter the fusion time.

Note 2: Gloves and goggles should be worn during the jointing process.

- Press the start button on the control box and check that the heating cycle is proceeding as indicated on the display.
- On completion of the heating cycle, the melt indicators, where incorporated should have risen. If there is no apparent move in the melt indicators, a new saddle joint should be made. Cut the tee of the faulty joint from its base.
- If a satisfactory joint has been made, the joint is to be left in the clamps for the cooling time specified on the fitting label or by the automatic control box.

Note 3: If the fusion cycle terminates before completion of the countdown, check for faults as indicated by the control box warning lights and check that there is adequate fuel in the generator. DO NOT attempt a second fusion cycle within one hour of the first attempt.

Note 4: The connection of the service pipe to the fitting outlet should be carried out in accordance with the procedure of the appropriate section of this Item.

Note 5: DO NOT attempt to tap the main with the integral cutter for at least 10 minutes after completion of the cooling cycle.

1.7 RECORDS

Records of appropriate servicing and calibration of Electro Fusion machines/ joints shall be kept.

1.8 TRAINING

AS PER 1.6

Note that some form of assessment and certification should be associated with the training. The certificate should detail the pipe and fitting size range and the equipment used. A register of successful participants should be kept.

1.9 STOPPING THE GAS FLOW

In the operation of a distribution system there is a periodic need to stop the gas flow for either routine or emergency maintenance. The flow may be stopped through the use of installed fittings such as valves. Where installed fittings are not available or the use of such would cause significant supply disruption, then one of the following methods may be employed.

1.10 SQUEEZE-OFF

- To control the gas flow a special tool may be used to squeeze the pipe walls together. Hydraulic jacks are used to supply the necessary force to compress the pipe walls for sizes 90 mm and above.
- It will be seen the squeeze-off equipment comprises two bars to apply pressure to the outside of the pipe. The bars are brought together, either manually or hydraulically, squeezing the pipe material together until a seal is formed where the upper and lower walls meet.
- The hydraulic machines should have a spring return for the jack and locking to prevent accidental release of pressure during operation. All squeeze-off machines should be fitted with check plate or stops to avoid over compression of the pipe.
- Where the pipe walls are compressed the polyethylene pipe will be severely deformed in the regions of maximum compression. The pipe will eventually regain its original shape after squeezing but there will be some reduction in the pressure bearing properties.
- A complete stop may not always be obtainable because of wrinkling of the inside of the pipe. If a complete stop is required then a second squeeze can be used, with an intermediate vent to remove the gas which passes the first squeeze from say the trench area. A second squeeze-off procedure should be a minimum of three pipe diameters and right angles to the initial squeeze.
- While not essential it would be good practice to fit a reinforcing stainless steel band do not squeeze again adhesive tape around the pipe upon the completion of a squeezing operation.

1.11 BENDING-BACK

Bending back of the pipe may be performed where the pipe has been severed damaged and stopping the gas flow is imperative. Its application is of a temporary nature, and will provide relief until a permanent repair can be affected. The section of pipe, which has been bent back, will have to be replaced because of the damage caused by the severe ness of the bend back operation. The need for any bend back operation is most likely to occur as a consequence of damage caused to a PE service pipe.

While it is not the prime function of a saddle tee, controlling the flow in a service may be achieved by opening up on an installed saddle tee and winding down the internal tapping tool to shut off the flow into the service pipe.

PTS- ELECTRO FUSION
FOR PE PIPES & FITTINGS

ANNEXURE # 1

FUSION COUPLERS FORM 20MM TO 180MM

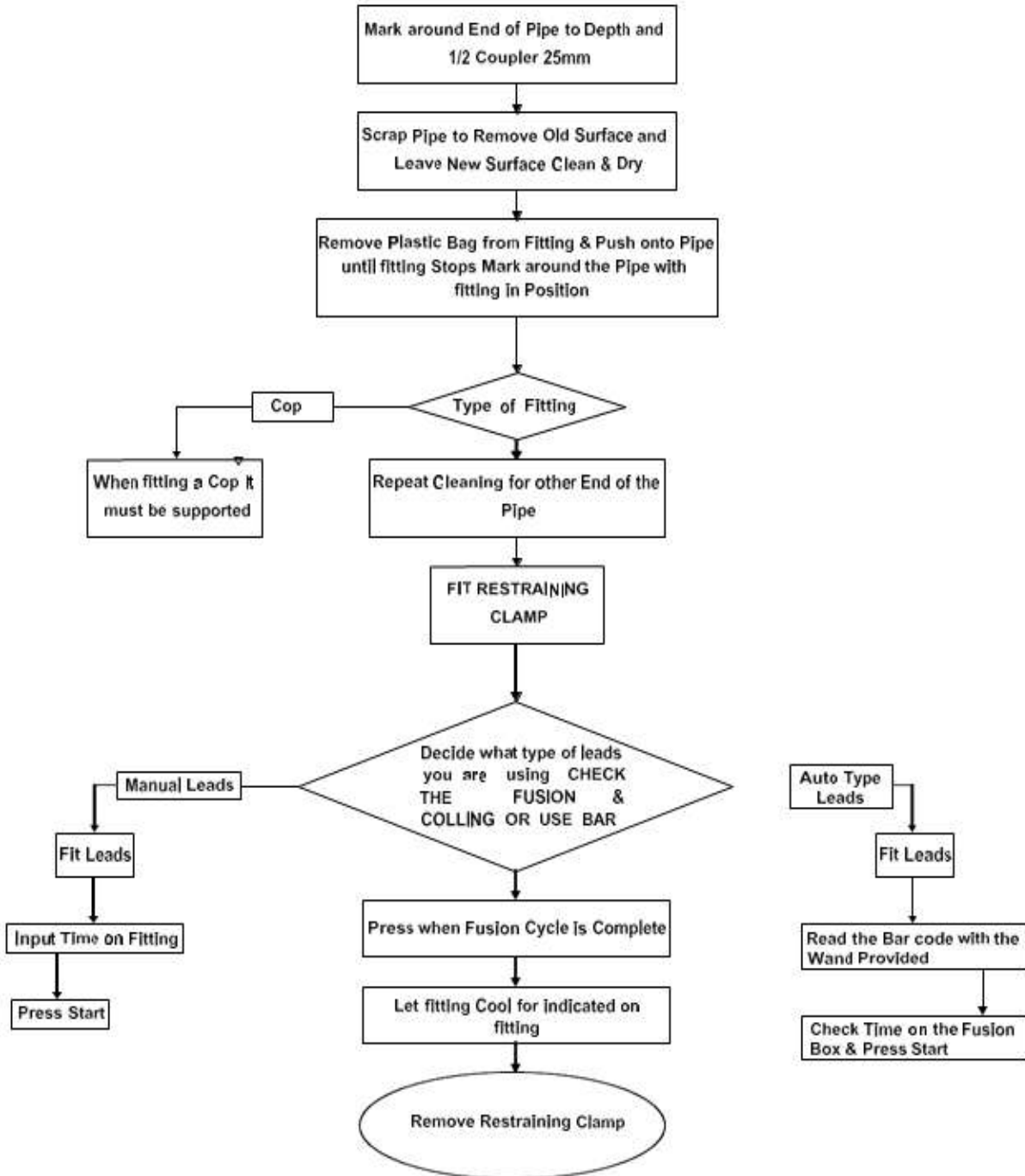

STANDARD SPECIFICATION OF

GI PIPES

CONTENTS

1.0	INTRODUCTION AND SCOPE	3
2.0	DEFINITIONS	3
3.0	MATERIAL	3
4.0	DIMENSIONS, THICKNESS & DIMENSIONALTOLERANCES.....	3
5.0	END CONNECTION OF PIPE.....	3
6.0	FREEDOM FROM DEFECTS	3
7.0	GALVANIZING	4
8.0	PRESSURE TEST.....	4
9.0	MARKING	4
10.0	INSPECTION / DOCUMENTS.....	5
11.0	PACKAGING	5

1.0 INTRODUCTION AND SCOPE

This present document covers the technical specification for the procurement of GI Pipes used in high pressure natural gas transportation and distribution systems. It describes the general requirements, controls, tests, QA/QC examination and final acceptance criteria which need to be fulfilled.

This specification covers the requirements for GI pipes of heavy steel tube. Unless modified by this specification, requirements of IS 1239 (Part-I): 2004 (Latest edition) shall be valid.

2.0 DEFINITIONS

Owner	Shall mean HPOIL Gas Private limited (HOGPL)
Manufacturer	Means the Manufacturer of the GI pipe.
SS	Means the present <<Standard Specification>> and all its appendix, if any.
TPIA	Means the Inspection Agency to be appointed by Owner.
GTS	Means the present <<General Technical Specification>> and its entire appendix, if any.

3.0 MATERIAL

The material used for the manufacturing of GI pipes confirming to IS 1239 (Part -1): 2004 (Latest edition).

4.0 DIMENSIONS, THICKNESS & DIMENSIONAL TOLERANCES

The dimensions & nominal mass of tubes shall be in accordance with Table 5 subject to the tolerances permitted in CL.8.1 & 9 of IS 1239 (Part-I) : 2004 (Latest edition). Length of each pipe shall be 6 mtrs with + 6, - 0 mm tolerance. However, pipe length shall be considered 6 m. only for measurement / payment purpose.

Nominal Diameter DN	15 mm	20 mm	25 mm	50 mm
Grade	Heavy	Heavy	Heavy	Heavy
Outer Dia. (Max. / Min.)	21.8 mm / 21.0 mm	27.3 mm / 26.5 mm	34.2 mm/33.3 mm	60.8 mm / 59.7 mm
Thickness (mm)	3.2	3.2	3.2	4.5
Nominal weight (Kg / m)	1.44	1.87	2.93	6.19

5.0 END CONNECTION OF PIPE

GI Pipes shall be supplied with plain end.

6.0 FREEDOM FROM DEFECTS

On visual examination the outside & inside surfaces of pipes shall be smooth & free from defects such as cracks etc.

7.0 GALVANIZING

- Pipes shall be galvanized to meet the requirement of IS: 4736 – 1986 with latest amendment.
- Zinc conforming to any grade specified in IS: 13229- 1991 with latest amendment shall be used for the purpose of galvanizing.
- Galvanizing bath: The molten metal in the galvanizing bath shall contain not less than 98.5% by mass of zinc.
- Mass of zinc coating: Minimum mass of zinc coating determined as per IS: 6745 shall be 360gms/m².
- Uniformity of galvanized coating: The galvanized coating when determined on a 100 mm long test piece in accordance with IS 2633: 1986 with latest amendment shall withstand 5 one – minute dips.
- Freedom from defect: The zinc coating on internal & external surfaces shall be uniform adhered, reasonably smooth & free from such imperfections as flux, ash & drop inclusions, bare patches, black spots, pimples, lumpiness runs, rust stains, bulky white deposits & blisters. Rejection & acceptance for these defects shall be as per Appendix - A of IS 2629: 1985 with latest amendments.
- **Samplings**
 - a) All materials of the same type in coating bath having uniform coating characteristics shall be grouped together to continue a lot. Each lot shall be tested separately for the various requirements of the specification. The number of units to be selected from each lot for this purpose shall be IS: 4711 1995 with latest amendment.
 - b) The sample selected according to Clause 6.1 & 6.2 of IS: 4736 – latest edition.
 - c) The sample found conforming to above requirements shall then be tested for mass of zinc coating in accordance with Clause 5.1 of IS: 4736 – 1986 with latest amendment.
 - d) Criteria for conformity: As per IS: 4736 – 1986 with latest amendments.

8.0 PRESSURE TEST

Hydrostatic pressure test shall be carried out at a pressure of 5 Mpa for the duration of at least 3 second and shall not show any leakage in the pipe. Vendor to submit the internal pressure test certificate for the same. Owner Representative or Third party Inspection Agency appointed by Owner shall witness finish goods testing as per the sample procedure specified in IS: 1239 (Part-1) – latest edition.

9.0 MARKING

Each pipe shall be embossed with Owner's logo, manufacturer's name or trademark, size designation, class of pipe at the interval of not more than 1 meters.

Each packing containing pipes shall carry the following embossed, stamped or written by indelible ink.

- Manufacturers name or trademark.
- Class of pipe –Heavy.
- Indian standard mark (ISI).
- Lot number / Batch no. of production.

Each pipe conforming to this standard shall also be marked with BIS standard mark.

10.0 INSPECTION / DOCUMENTS

Inspection shall be carried out as per Owner Technical Specification.

Owner Representative or Third Party Inspection Agency appointed by Owner shall carry out stage wise inspection during manufacturing / final inspection.

The manufacturer shall have a valid license to use ISI monogram for manufacturing of pipe in accordance with the requirement of IS: 1239.

Vendor shall furnish all the material test certificates, proof of approval / license from specified authority as per specified standard, if relevant, internal test / inspection reports as per Owner Tech. Spec. & specified code for 100% material, at the time of final inspection of each supply lot of material.

For any control, test or examination required under the supervision of TPIA/Owner/Owner's representative, latter shall be informed in writing one (1) week in advance by vendor about inspection date and place along with production schedule.

Even after third party inspection, Owner reserves the right to select a sample of pipes randomly from each manufacturing batch & have these independently tested. Should the results of these tests fall outside the limits specified in Owner technical specification, then Owner reserves the right to reject all production supplied from the batch.

11.0 PACKAGING

Packing size to be mentioned to ensure uniformity in delivery conditions of the material being procured. Bidder shall submit the packaging details during QAP and also complied with at the time of delivery.

STANDARD SPECIFICATION OF
GI FITTINGS

CONTENTS

1.0	SCOPE	3
2.0	DEFINATIONS	3
3.0	MATERIAL.....	3
4.0	DIMENSIONS THICKNESS & DIMENSIONAL TOLERANCES	3
5.0	WEIGHT.....	3
6.0	THREADS	3
7.0	FREEDOM FROM DEFECTS	4
8.0	GALVANIZING	4
9.0	PRESSURE TEST	4
10.0	COMPRESSION TEST	4
11.0	SAMPLING	4
12.0	MARKING	5
13.0	PACKAGING	5
14.0	INSPECTION / DOCUMENTS	5

1.0 SCOPE

This present document covers the technical specification for the procurement of GI fittings used in high pressure natural gas transportation and distribution systems. It describes the general requirements, controls, tests, QA/QC examination and final acceptance criteria which need to be fulfilled.

This specification covers the requirements for Malleable Cast Iron Fittings unless modified by this specification, requirements of IS 1879 – latest edition shall be valid.

2.0 DEFINITIONS

Owner	Shall mean HPOIL Gas Private limited (HOGPL)
Manufacturer	Means the Manufacturer of the GI fittings.
SS	Means the present <<Standard Specification>>and its appendix, if any.
TPIA	Means the Inspection Agency to be appointed by Owner.

3.0 MATERIAL

The material used for the manufacturing of GI fittings shall conform to ISI 14329 – 1995 with latest amendments Grade BM 300.

4.0 DIMENSIONS THICKNESS & DIMENSIONAL TOLERANCES

- Dimensions of various types of fittings shall be as specified in sections 2 to 10 of IS 1879 – 1987 with latest amendments, as applicable.
- Wall thickness of fittings and tolerances on them shall be as given in Table 1.2 of S 1879 – 1987 with latest amendments,
- In case of reducing fittings, the dimensions at each outlet shall be those appropriate to the nominal size of the outlet.
- Elbows, Tees, Sockets and caps shall be of reinforced type.

5.0 WEIGHT

Weights of various types of fittings shall be as specified in sections 2 to 10 of S 1879 – 1987 with latest amendments, as applicable.

6.0 THREADS

- Threads shall be NPT type and conforming to ASME B1.20.1.
- Outlets of fittings shall be threaded to dimensions & the tolerances as specified in ASME B1.20.1.
- All internal & external threads shall be tapered.
- For checking conformity of threads gauging practice in accordance with ASME B1.20.1 shall be followed.
- Chamfering: The outlet of fittings shall have chamfer.

7.0 FREEDOM FROM DEFECTS

On visual examination, the outside & inside surfaces of fittings shall be smooth & free from any defects such as cracks, injurious flaws, fine sand depth etc.

8.0 GALVANIZING

- Fittings shall be galvanized to meet the requirement of IS: 4759-1996 with latest amendments.
- Zinc conforming to any grade specified in IS: 13229-1991 with latest amendments shall be used for the purpose of galvanizing.
- Galvanizing bath: The molten metal in the galvanizing bath shall contain not less than 98.5% by mass of zinc.
- Coating requirements: Mass of coating shall be 610 - 700gms/m².
- Freedom from defect: The zinc coating shall be uniform adhered, reasonably smooth & free from such imperfections as flux, ash bare patches, black spots, pimples, lumpiness runs, rust stains, bulky white deposits & blisters.
- **Samplings**
 - a. All materials of the same type in coating bath having uniform coating characteristics shall be grouped together to continue a lot. Each lot shall be tested separately for the various requirements of the specification. The number of units to be selected from each lot for this purpose shall be given in Table 2 of IS 4759 –latest edition.
 - b. The sample selected according to Column 1 & 2 of Table 2, IS: 4759 – latest edition shall be tested for visual requirements as per Clause 6.2 of IS:4759 –latest edition
 - c. The sample found conforming to above requirements shall then be tested for mass of zinc coating in accordance with Clause 9.2 of IS: 4759 – latest edition.
 - d. Criteria for conformity: As per Clause 8.3 of IS: 4759-latest edition.
 - e. Test procedure shall be as per Clause 9 of IS: 4759-latest edition.

9.0 PRESSURE TEST

Vendor shall carry out pneumatic pressure test as per Clause 11.1b of 1879 – 1987 with latest amendments on each & every fittings. Vendor to submit the Internal Quality control certificate for the same. Owner shall witness pneumatic testing as per the sampling procedure specified in 1879 – 1987 with latest amendments.

10.0 COMPRESSION TEST

This test shall be conducted to judge the malleability of the pipe fittings & shall be carried out as per Clause 12 of 1879 – 1987 with latest amendments.

11.0 SAMPLING

Owner Representative of Third Party Inspection Agency appointed by Owner shall witness the tests as per clause 14 of 1879 – 1987 with latest amendments. However, vendor to perform 100% inspection of visual, dimensional & pressure test. Vendor shall furnish Internal test certificates at the time of final inspection to the Owner.

12.0 MARKING

Each fitting shall be embossed with OWNER's logo, manufacturer's name or trademark and the size designation.

Each packing containing fittings shall carry the following embossed, stamped or written by indelible ink.

- Manufacturer's name or trademark.
- Designation of fittings.
- Lot number.

Each fitting conforming to this standard shall also be marked with BIS standard mark.

13.0 PACKAGING

Packing size to be mentioned to ensure uniformity in delivery conditions of the material being procured. Packing size shall be approved by owner / owner's representative before packing the material. The vendor shall submit the packaging details during QAP and also complied with at the time of delivery.

14.0 INSPECTION / DOCUMENTS

- Inspection shall be carried out as per Owner Technical Specification.
- Owner Representative or Third-Party Inspection Agency appointed by Owner shall carry out stage wise inspection during manufacturing / final inspection.
- Vendor shall furnish all the material test certificates, proof of approval / license from specified authority as per specified standard, if relevant, internal test / Inspection reports as per Owner Tech Spec. & specified code for 100% material, at the time of final inspection of each supply lot of material.

STANDARD SPECIFICATION OF
BRASS FITTINGS

CONTENTS

1.0	SCOPE	3
2.0	MATERIAL	3
3.0	DIMENSIONAL TOLERANCES	3
4.0	END CONNECTION	3
5.0	CHEMICAL PROPERTIES	3
6.0	CARBON IN BORE	3
7.0	RESISTANCE TO DEZINCIFICATION	4
8.0	STRESS CORROSION RESISTANCE TEST	4
9.0	FREEDOM FROM DEFECT	4
10.0	HYDROSTATIC PRESSURE TEST	4
11.0	PNEUMATIC PRESSURE TEST	4
12.0	MARKING	4
13.0	PACKAGING	4
14.0	INSPECTION/ DOCUMENTS	4

1.0 SCOPE

This specification covers the requirements for Brass Capillary fittings (End feed fittings). Unless modified by this specification, requirement of BS 864 / EN 1254 Part 1 shall be valid.

2.0 MATERIAL

- The material used for the manufacturer of Brass Capillary Fittings shall conform to EN 1254-1 (latest), Half Hard.
- Material used for the solder should conform to BS EN 29453 and should be lead free. Solder material shall be generally melting within the temperature range 180 ° C to 250 °C.
- Threading on the Brass fittings shall be done as per BS21.

3.0 DIMENSIONAL TOLERANCES

Dimensions tolerances of various types of brass capillary fittings (End feed fittings). shall be as per EN 1254 Part 1.

The tolerances at the end shall be as per EN 1254 Part I in nominal diameter which is as follows (Ref. table below)

Diameter	Tolerance on the mean diameter with respect to the nominal diameter		Resulting Diametrical difference	
	Outside Dia of male end (mm)	Inside Dia of socket (mm)	Max (mm)	Min (mm)
12 mm	+0.04	+ 0.15	0.20	0.02

The minimum wall thickness of a fitting shall be in accordance as given below (Ref Table 3 of EN 1254 Part 1)

<u>Nominal Dia mm D</u>	<u>Minimum Wall thickness (mm) Brass</u>
12	1.1

4.0 END CONNECTION

End connection of the fitting must be capable of end feeding to the NPT x 12 mm. Internal solder ring type fitting is not acceptable.

5.0 CHEMICAL PROPERTIES

Chemical composition of Brass shall be as mentioned in EN 1254 PART I. Dezincification-resistant brass material CuZn36Pb2As or CW602N.

Cu	61.0-63.0 %
Pb	01.7-02.8 %
As	0.02 -0.15%

Remaining is zinc.

6.0 CARBON IN BORE

The internal surface of brass capillary fittings for soldering or brazing shall not contain any detrimental film nor present a carbon level high enough to allow the formation of such a film during installation. The maximum total carbon level on internal surfaces shall not

exceed 1.0 mg/dm^2 when tested in accordance with the specification. This test shall be carried out as per clause no. 5.4 of EN 1254 -1.

7.0 RESISTANCE TO DEZINCIFICATION

The fittings shall be manufactured from alloys containing more than 10% Zinc. So fittings shall be required to be resistant to dezincification. It shall be carried out as per Cl. 5.5 of EN 1254 -1.

8.0 STRESS CORROSION RESISTANCE TEST

A stress corrosion resistance is to be carried out as per method defined in ISO 6957 using test solution of pH9.5 but without pickling.

9.0 FREEDOM FROM DEFECT

The fittings shall be free from internal fins, blow holes, skin defects etc. or other irregularities which might restrict the free flow of fluid, and shall be designed that resistance to the flow of fluid through the fittings is minimized.

10.0 HYDROSTATIC PRESSURE TEST

All fittings shall be leak tightness tested at 1.5×25 bars for a period of 15 minutes and no leakage is permitted. This test shall be performed on each size of the fittings.

11.0 PNEUMATIC PRESSURE TEST

All fittings shall be leak tested at 6 bars for a period of 10 seconds and no leakage is permitted.

MARKING

Each fittings shall be embossed with OWNER' s logo, manufacturers name and trade mark BS 864 / EN 1254 Part- I and designation of fittings.

Each packing containing fittings shall carry the following stamped or written in indelible ink.

13.0 PACKAGING

Packing size to be mentioned to ensure uniformity in delivery conditions of the material being procured. Bidder shall submit the packaging details during QAP and also complied with at the time of delivery.

14.0 INSPECTION/ DOCUMENTS

- Inspection shall be carried out as per design codes/standards, OWNER Technical Specification and Inspection Plan/ Vendor's detailed QAP duly approved by owner/owner's consultant.
- OWNER's consultant or third-party inspection agency appointed by OWNER shall carry out random inspection during manufacturing/ final inspection.
- Vendor shall furnish all the material test certificates, proof of approval/ license from specified authority as per specified standard, if relevant, internal test/ inspection reports as per OWNER Technical Specification, at the time of final inspection of each supply lot of material.
- Even after third party inspection, OWNER reserves the right to select a sample of tube randomly from each manufacturing batch and have these independently tested. If the results of these tests fall outside the limits specified in OWNER Technical specification, then OWNER reserves the rights to reject all production supplied from the batch.

- Vendor shall prepare and submit the detail drawings of required brass fitting for approval by OWNER/VCSQSPL before starting production.
- For any control test or examination required under the supervision of TPIA/owner/owner's consultant, latter shall be informed in writing one (1) week in advance by vender about inspection date & place along with production schedule.

STANDARD SPECIFICATION FOR STEEL
REINFORCED RUBBER HOSE

CONTENTS

1.0	SCOPE	3
2.0	SPECIFICATION FOR POWDER COATING.....	3
3.0	MATERIAL.....	3
4.0	DIMENSIONS & TOLERANCES.....	3
5.0	FEATURES.....	3
6.0	MARKING.....	4
7.0	PACKAGING	4
8.0	INSPECTION/ DOCUMENTS.....	5

1.0 SCOPE

This present document covers the technical specification for the procurement of steel reinforced rubber hose, Type 4 used in distribution systems. It describes the general requirements, controls, tests, QA/QC examination and final acceptance criteria which need to be fulfilled.

This specification covers the requirements for steel reinforced rubber hose unless modified by this specification, requirements of IS: 9573 shall be valid.

2.0 SPECIFICATION FOR POWDER COATING

Owner	Shall mean HPOIL Gas Private limited (HOGPL)
Manufacturer	Means the Manufacturer of the Steel Reinforced Rubber Hose.
PTS	Means the present <<Particular Technical Specification>> and its appendix, if any.
TPIA	Means the Inspection Agency to be appointed by OWNER.
Type 4	Wire Reinforced hose for domestic / commercial installations

3.0 MATERIAL

- Lining: - It shall be nitrile – butadiene rubber (NBR) or chloroprene rubber (CR) compound. It shall be smooth in bore, uniform in thickness and free from air blisters, porosity and splits.
- Reinforcement material: - It shall have wire reinforcement in braided form in between the lining & cover.
- Cover: - It shall be manufactured out of synthetic rubber compound resistant to abrasion, weather and natural gas. The cover color shall be orange.
- The whole shall be consolidated by wrapping or any other suitable method and uniformly vulcanized to give good adhesion between reinforcement plies and the rubber lining of the cover.

4.0 DIMENSIONS & TOLERANCES

- Bore size

Nominal base (mm)	Minimum base diameter (mm)	Minimum bend radius (mm)
8mm	7.9	95

The Nominal bore size of the hose shall be accordance to table # 1 of IS 9573: 1998 shall be as given above table. It shall be tested/ checked as method defined in IS 4143.

- The Minimum thickness so lining & cover shall be 2 mm & 1 mm respectively.
- Length of hose shall be as defined in M.R. & the tolerances on length shall be permitted $\pm 1\%$.

5.0 FEATURES

- **Mechanical properties**

Tensile Strength (Lining & Cover) at break - 10 MPa (minimum)

Elongation (Lining & Cover) in at break (%) - 200 & 250 respectively (minimum)

- **Resistance of Lining to n-pentane**

The n-pentane absorbed and the n-pentane extractable matter as determined Clause no. 5.4.3.2 of IS 9573: 1998 shall not exceed 10% & 5% respectively to the initial mass of lining.

- **Adhesion**

The minimum adhesion between rubber lining & reinforcement, between layers of reinforcement and between reinforcement & cover shall be 2KN/m.

- **Low temperature flexibility**

Flexible hose is conditioned at - 40 ° C for at least 5 hrs. and then bent at 180° around a mandrel with a diameter 12 times the nominal bore diameter of the hose, no cracks or breaks shall be shown.

- **Flexibility of Hose**

The hose shall be capable of being bent empty to the radius 95 mm without flattening and suffering structural damages.

- **Ozone resistance**

It shall be carried out as per clause no. 5.5 of IS 9573: 1978

- **Hydro static test**

All hoses shall be leak tightness tested at 2 MPa for a period of 1 minutes and no leakage is permitted. This test shall be performed on each size of the hoses as per clause no. 5.5.5.1 of IS 9573: 1978.

- **Bursting pressure**

It shall be carried out as per Clause 5.5.2 of IS 9573. The minimum burst pressure shall be 5 Mpa.

- **Grip strength test**

The hose shall comply to the requirement of Clause no. 5.5.7 of IS 9573.

- **Burning behavior**

The burning test shall be carried out on hose as per clause no. 5.5.8 of IS9573. The hose at least shall not burn till 45second.

6.0 MARKING

Each hose shall be indelibly marked as follows:

- Manufacturer's name or trade mark., if any
- Nominal bore
- Batch no. / Lot no.
- Month and year of manufacturer
- Type of hose i.e. Type 4
- BIS marking

7.0 PACKAGING

Packing size to be mentioned to ensure uniformity in delivery conditions of the material

being procured. Bidder shall submit the packaging details during offer and also complied with at the time of delivery.

8.0 INSPECTION/ DOCUMENTS

- Inspection shall be carried out as per design codes/standards, OWNER Technical Specification and Inspection Plan/ Vendor's detailed QAP duly approved by owner/owner's consultant.
- For all test's purposes, the minimum time between vulcanization & testing shall be 16h.
- OWNER's consultant or third-party inspection agency appointed by OWNER shall carry out random inspection during manufacturing/ final inspection.
- Vendor shall furnish all the material test certificates, proof of approval/ license from specified authority as per specified standard, if relevant, internal test/ inspection reports as per OWNER Technical Specification, at the time of final inspection of each supply lot of material.
- Even after third party inspection, OWNER reserves the right to select a sample of hose randomly from each manufacturing batch and have these independently tested. If the results of these tests fall outside the limits specified in OWNER Technical specification, then OWNER reserves the rights to reject all production supplied from the batch.
- Vendor shall prepare and submit the detail drawings of required steel reinforced rubber hose for approval by OWNER /VCSQSPL before starting production.
- For any control test or examination required under the supervision of TPIA/owner/owner's consultant, latter shall be informed in writing one (1) week in advance by vender about inspection date & place along with production schedule.

**STANDARD SPECIFICATION FOR
PURE POLYESTER POWDER COATING**

CONTENTS

1.0	SCOPE	3
2.0	SPECIFICATION FOR POWDER COATING	3
3.0	TESTING	3
4.0	MARKING	3
5.0	INSPECTION/ DOCUMENTS	4

1.0 SCOPE

This Specification specifies the requirements for powder coating (Pure Polyester) of GI Pipes & fitting suitable to use for carrying Natural Gas directly expose to sunlight.

2.0 SPECIFICATION FOR POWDER COATING

Powder Material	:	Pure Polyester.
Application	:	Electrostatic Spraying (40 — 90 KV Manual/ Automatic)
Backing Schedule	:	180 ⁰ C to 200 ⁰ C for 10 mm (Metal Temperature) Coating
Thickness	:	50-60Microns

3.0 TESTING

Film Type	:	Glossy/Satin 86
Gloss600	:	95%
Cross Hatch Adhesion (ASTM D-5870)	:	GT = 0/100
Cylindrical bending Test (ASTM D -522) 5mm Rod dia	:	Passes
Enrichsen cupping (min)	:	8 Passes
Pencil Hardness(mm)	:	2H
Scratch Resistance (Kg. Mm)	:	3
Impact Resistance Kg. Min (ASTM D- 2794)	:	Direct 150 Indirect 150
Salt Spray Resistance (ASTM B-117)	:	1000 Hrs. (min)
Porosity (DIN 53161)	:	Passes
Humidity Resistance	:	1000 Hrs. (min)

4.0 MARKING

Each fitting shall be embossed with manufacture's name or trademark and the size

designation. Each packing containing fittings shall carry the following stamped or written by indelible ink.

- Manufacturers name or trademark.

- Designation of fitting.
- Lot number.

Each fitting conforming to this standard shall also be marked with BIS standard mark.

5.0 INSPECTION/ DOCUMENTS

- Inspection shall be carried out as per OWNER Technical Specification.
- OWNER representative or Third-Party Inspection Agency appointed by OWNER shall carry out stage wise inspection during manufacturing/final inspection.
- Vendor shall furnish all the material test certificates, proof of approval/ license from specified authority as per specified standard, if relevant, internal test inspection reports as per OWNER Tech Spec. &- specified code for 100% material, at the time of final inspection of each supply lot of material.
- Even after third party inspection, OWNER/ OWNER's Consultant reserves the rights to select a sample of fittings randomly from each manufacturing batch & have these independently tested. Should the results of these tests fall outside the limits specified in OWNER technical specification, then OWNER/ OWNER's Consultant Reserves the rights to reject all production supplied from the batch. **(ASTM D-2247)**

Weathering : 60-70% Gloss retention after 1000Hrs.

(sun test with water
immersion, Xenon
150K.lux)

Colour : Light colour as approved by OWNER/CONSULTANT

STANDARD SPECIFICATION – FORGED FITTINGS
(WROUGHT STEEL FITTINGS)
FOR USE AT

PRESSURE UP TO 100 MBAR (G)

CONTENTS

1.0	SCOPE	3
2.0	SPECIFICATION FOR POWDER COATING	3
3.0	MATERIAL	3
4.0	DIMENSIONS & TOLERANCES	3
5.0	THREADS	3
6.0	FREEDOM FROM DEFECTS	3
7.0	GALVANIZING	3
8.0	PRESSURE TEST	4
9.0	COMPRESSION TEST	4
10.0	SAMPLING	4
11.0	MARKING	4
12.0	PACKAGING	5
13.0	INSPECTION/ DOCUMENTS	5

1.0 SCOPE

This specification covers the requirements for Wrought Steel Fittings for Natural Gas for use at pressures up to 100 mbar (g). Unless modified by this specification, all the requirements of IS 1239 Part 2: 1992 and the latest editions of the standards mentioned herein this specification, including all revisions, shall apply.

2.0 SPECIFICATION FOR POWDER COATING

Owner	Shall mean HPOIL Gas Private Limited (HOGPL)
Manufacturer	Means the Manufacturer of the Steel Reinforced Rubber Hose.
SS	Means the present <<Standard Specification>> and its appendix, if any.
TPIA	Means the Inspection Agency to be appointed by Owner.

3.0 MATERIAL

The material used for the manufacturing of wrought steel fittings shall conform to IS 1387: 1967 generally, and IS 1239 Part 2: 1992

4.0 DIMENSIONS & TOLERANCES

- Dimensions of various types of fittings shall be as specified in the table 1 to 31 of IS 1239 Part 2: 1992.
- Wall thickness on fittings & tolerances on them shall be as given in table 1 to 31 of IS 1239 Part 2: 1992.
- In case of reducing fittings, the dimensions at each outlet shall be those appropriate to the nominal size of the outlet.

5.0 THREADS

- Outlet of fittings shall be threaded to dimensions & the tolerances as specified in IS 554: 1999.
- All internal & external threads shall be tapered.
- After threading, the pipe body may be hot dip galvanized as per normal practice followed by cold galvanizing (spraying) of the threaded portions. The threaded portions shall be protected using end caps, etc.
- For checking conformity of threads gauging practice in accordance with IS 8999: 2003 shall be followed.
- Chamfering: The outlet of fittings shall have chamfer. The chamfer shall have an included angle of $90^\circ \pm 50$ for internal threads & $70^\circ \pm 100$ for external threads.

6.0 FREEDOM FROM DEFECTS

On visual examination the outside & inside surfaces of fittings shall be smooth & free from defects such as cracks, injurious flows, fine sand depth, etc. Other workmanship shall be as per Clause 14 of IS 1239 Part 2: 1992.

7.0 GALVANIZING

- Fittings shall be galvanized to meet the requirements of IS 4759: 1996.
- Zinc conforming to any grade specified in IS 209: 1992 or IS 13229: 1991 shall be used for the purpose of galvanizing.

- **Galvanized Bath:** The molten metal in the galvanizing bath shall contain not less than 98.5% by mass of zinc.
- **Coating requirements:** Mass of coating shall be 610 gms/ m². In case of pipe nipples (manufactured in accordance with the requirements of IS 1239 Part 1: 2004), the mass of coating of 400 gms/m² shall also be acceptable.
- **Freedom from defects:** The zinc coating shall be uniformly adhered, reasonably smooth & free from such imperfections as flux, ash bare patches, black spots, pimples, lumpiness runs, rust strains, bulky white deposits & blisters; otherwise the pipes shall be liable for rejection.
- **Sampling Plan for galvanizing**
 - a) All materials of the same type in a coating bath having uniform coating characteristics shall be grouped together to constitute a lot. Each lot shall be tested separately for the various requirements of the specification. The number of units to be selected from each lot for this purpose shall be as given in Table 2 of IS 4759: 1996.
 - b) The sample selected according to Column 1 & 2 of Table 2, IS 4759: 1996 shall be tested for visual requirements as per Para 8 of IS 4759: 1996. Vendor shall have appropriate correspondence between galvanizing lot number and pipe manufacturing lot number for identification / traceability.
 - c) The sample found conforming to above requirements shall then be tested for mass of zinc coating in accordance with Clause 9.2 of IS 4759: 1996.
 - d) Criteria for conformity: As per Clause 8.3 of IS 4759: 1996.
 - e) Test procedure shall be as per Clause 9 of IS 4759: 1996. All galvanizing test results shall be included in the Manufacturer's Test Certificate.

8.0 PRESSURE TEST

Pneumatic pressure test shall be carried out on each & every fittings as per procedure given in IS 1239 Part 2: 1992.

9.0 COMPRESSION TEST

As per IS 1239 Part 2: 1992.

10.0 SAMPLING

Owner's consultant or Third-Party Inspection Agency appointed by Owner shall witness the tests as per procedure for sampling plan given in IS 4711: 1974. However, vendor to perform 100% inspection of visual, dimensional & pressure test. Vendor shall furnish Internal test certificates at the time of final inspection to the Owner.

11.0 MARKING

Each fitting shall be embossed with Owner's logo, manufacturer's name or trademark and the size designation.

Each packing containing fittings shall carry the following embossed, stamped or written by indelible ink.

- Manufacturer's name or trade mark.
- Designation of fittings.
- Lot number.

Each fitting conforming to this standard shall also be marked with BIS standard mark.

12.0 PACKAGING

Packing size to be mentioned to ensure uniformity in delivery conditions of the material being procured. Packing size shall be approved by owner / owner's representative before packing the material. The vendor shall submit the packaging details during QAP and also complied with at the time of delivery.

13.0 INSPECTION / DOCUMENTS

- Inspection shall be carried out as per Owner Technical Specification.
- Owner's Consultant or Third-Party Inspection Agency appointed by Owner shall carry out stage wise inspection during manufacturing / final inspection.
- Vendor shall furnish all the material test certificates, proof of approval / license from specified authority as per specified standard, if relevant, internal test / Inspection reports as per Owner Tech Spec. & specified code for 100% material, at the time of final inspection of each supply lot of material.
- Even after third party inspection, Owner reserves the rights to select a sample of fittings randomly from each manufacturing batch & have these independently tested. Should the results of these tests fall outside the limits specified in Owner technical specification, then Owner reserves the rights to reject all production supplied from the batch.

STANDARD SPECIFICATION FOR
WARNING MAT

CONTENTS

1.0	SCOPE	3
2.0	DEFINATIONS	3
3.0	REFERENCE CODE.....	3
4.0	FEATURES	3
5.0	QUALITY ASSURANCE (QA)	4
6.0	DEFECT LIABILITY.....	4
7.0	APPENDIX - I.....	4

1.0 SCOPE

The present document covers the technical specifications for the procurement of Warning Mat. Warning mats shall be laid in the ground above the gas main line in order to indicate their presence.

2.0 DEFINITIONS

Owner	Shall mean HPOIL Gas Private Limited
Manufacturer	Means the Manufacturer of the Warning Tap/Mat
SS	Means the present <<Standard Specification>>
TPIA	Means the Inspection Agency to be appointed by Owner.

3.0 REFERENCE CODE

IS 10889	High Density Polyethylene Films
ASTM D - 638	Standard test method for tensile properties of plastics.

4.0 FEATURES

- **Material**

Raw material of the warning mat shall be Virgin material.

The material grade of Warning Mat shall be HDPE with warning sticker / stamp.

- a. Mechanical properties
- b. Tensile strength at break (Machine direction) - 300 Kgf /cm²(minimum)
- c. Elongation in machine & Transverse direction (%) - 300 (minimum)

- **Colour**

The Mat shall be of bright golden yellow colour. This colour must not take any appreciable alteration in the course of time.

- **Dimensions**

Warning Mat shall have following dimensions:

Width 300 mm ± 5 mm

Thickness 1 mm (Minimum)

Negative tolerance on thickness is not allowed.

- **Marking**

- a. Marking on the Mat shall be approved by owner. The warning Mat shall be provided with Chainage marking and the warning mat must be engraved with "Caution: High pressure gas pipeline below" in both English and Hindi along with OWNER's Logo at a frequency of every meter.

- b. Vendor shall submit proposed Artwork to be marked on the Mat for the approval from Owner / Owner's Consultant.

- **Tests**

- a. Colour- Fast test

Test specimen 100 mm to 150 mm wide shall be immersed in a 20% solution of ammonium sulphide at 15 to 20 °C temperature for 15 days. The colour fastness shall be evaluated by comparing the test specimen with a sample specimen. The comparison shall be made by placing the two specimens on a white back ground in day light, but without exposing them directly to sun light. Test shall be accepted satisfactory, if the colour of the strip remains intact.

- b. Other tests shall be carried out as per relevant national / international standard enclosed in QAP.

- **Packing**

The warning mat shall be delivered in rolls of 50meters. Packing size to be mentioned to ensure uniformity in delivery conditions of the materials being procured. Bidder shall submit the packing details during offer and also compiled with at the time of delivery.

5.0 QUALITY ASSURANCE (QA)

Manufacturer shall prepare detailed QAP and submit for the approval from Owner / Owner's Consultant.

6.0 DEFECT LIABILITY

Defect liability period shall be as per the commercial volume I of II

7.0 APPENDIX - I

Vendor to submit the following Data along with BID.

SR.NO.	DESCRIPTION	UNIT	DATA	REMARKS
01.	Average gravimetric Thickness	mm		
02.	Tensile strength at Break (in machine direction)	Kg / cm2		
03.	Tensile strength at Break (in Transverse direction)	Kg / cm2		
04.	Elongation at Break (in Transverse direction)	%		
05.	Elongation at Break (in Transverse direction)	%		
06.	Color bleeding	-		
07.	Dimensional stability	% change		

STANDARD SPECIFICATION – MEDIUM DENSITY
POLYETHYLENE BALL VALVE

TABLE OF CONTENTS

1.0	SCOPE	3
2.0	APPLICABLE CODES, SPECIFICATIONS AND STANDARDS	3
3.0	ABBREVIATIONS & TERMINOLOGY	4
4.0	TECHNICAL REQUIREMENT	4
5.0	MATERIAL	5
6.0	DESIGN	6
7.0	DIMENSIONS & TOLERANCE	7
8.0	DOCUMENT REQUIREMENT	7
9.0	QUALITY ASSURANCE PLAN	8
10.0	MARKING	8
11.0	PACKAGING	9

1.0 SCOPE

This technical specification along with datasheet specifies the minimum requirements for design, selection, manufacture, inspection, testing and supply of MDPE Ball Valves and its component made from extruded or injected moulded polyethylene (PE).

This specification elaborates the requirement of MDPE Ball Valve for natural gas distribution systems at operating pressure and operating temperature 4 barg and 250C respectively.

This specification is limited to valves with a nominal diameter (de/do) up to and including 180 mm.

Material of grade shall be PE 100 & SDR 11.

2.0 APPLICABLE CODES, SPECIFICATIONS AND STANDARDS

EN 1555-1: Plastics piping systems for the supply of gaseous fuels- Polyethylene (PE) - part 1: General

EN 1555-2 / ISO 4437-2 / IS-14885: Plastics piping systems for the supply of gaseous fuels- Polyethylene (PE)

EN 1555-3: Plastics piping systems for the supply of gaseous fuels- Polyethylene (PE) - part 3: Fittings

EN 1555-4: Plastics piping systems for the supply of gaseous fuels- Polyethylene (PE) - part 4: Valves

EN 1555-5: Plastics piping systems for the supply of gaseous fuels- Polyethylene (PE) - part 5: Fitness for purpose of the system

EN 1555-7: Plastics piping systems for the supply of gaseous fuels- Polyethylene (PE) - part 7: Guidance for assessment of conformity

ISO TR 13950:1997 or latest edition: Plastics pipes and fittings - Automatic recognition systems for Electro fusions

ISO/IEC 16390:1999 or latest edition: Information technology – Automatic identification and data capture techniques – Bar code symbology specification-Interleaved 2 of 5

ISO 12176-4: Plastics pipes and fittings - Equipment for fusion jointing polyethylene system - part 4: Traceability coding

ISO 17778: Plastics piping systems- Fittings, valves and ancillaries - Determination of gaseous flow rate/pressure drop relationships.

EN ISO 1133, Plastics – Determination of the melt mass-flow rate (MFR) and the melt volume-flow rate (MVR) of thermoplastics

ISO 3126: Plastics piping systems -- Plastics piping systems — Plastics piping components — Measurement and determination of dimensions

PNGRB and other referrals in the above applicable codes.

3.0 ABBREVIATIONS & TERMINOLOGY

d_n / d_o	:	Nominal Outside Diameter
e_n	:	Nominal Wall Thickness
SDR	:	Standard Dimension Ratio = d_n / e_n
LTHS	:	Long Term Hydrostatic Strength (at 20°C for 50yrs)
LCL	:	Lower Confidence Limit – Stress value (MPa) of mean LTHS
MRS	:	Minimum Required Strength – min. value (in MPa) for LTHS of material
C	:	Design Co-efficient – As per ISO: 12162 Table-2
σ_s	:	Design Stress (= MRS/C)
MFR	:	Melt Mass Flow rate – Value related to viscosity of the molten material at a specified temp. and rate of shear. (expressed in g/10min.)
D_r	:	De-rating Co-efficient (Refer Table A.1, Annex A – EN 1555-5)
MOP	:	Maximum Operating Pressure = $(20 \times MRS) / \{(SDR-1) \times C \times D_r\}$
EF	:	Electrofusion

4.0 TECHNICAL REQUIREMENT

- 4.1 Design of valve shall be as per European Standards EN 1555-4 and the complementary particular requirement.
- 4.2 Valves shall be leak proof and it is intended to be use in gas distribution networks made of PE pipes and accessories.
- 4.3 The valves are laid and to be welded by means of electrofusion method.
- 4.4 The internal and external surfaces of valves shall be smooth, clean and free from scoring, cavities or other surface defects to an extent that would prevent conformity to EN 1555-4.
- 4.5 No component of valve shall show any damage, scratches, pitting, bubbles, blisters, inclusions or crack.

4.6 Mechanical characteristics of assembled valves:

- a) Valve shall have mechanical characteristics conforming to the requirements given in Table-1 of standard EN 1555-4.
- b) Unless otherwise specified by the applicable test method, the test pieces shall be conditioned at (23 ± 2) °C before testing.
- c) Testing of valve shall be in accordance with the test methods as specified in Table-1 of standard EN 1555-4 using the indicated parameters.
- d) Hydrostatic test pressure and minimum test period shall be as per Table-2 of EN 1555-4.

4.7 Physical characteristics of assembled valves:

- a) Valve shall have physical characteristics conforming to the requirements given in Table-3 of standard EN 1555-4.
- b) Thermal stability test shall be done at 200 deg. C by means of differential scanning calorimetry (DSC), considering oxygen induction time (OIT) ≥ 20 min.
- c) Melt mass flow rate shall be calculated at 190 deg. C by applying 5 Kg of load on test specimen. It shall be expressed in g/ 10min.
- d) Unless otherwise specified by the applicable test method, the test pieces shall be conditioned at (23 ± 2) °C before testing.
- e) Testing of valve shall be in accordance with the test methods as specified in Table-3 of standard EN 1555-4 using the indicated parameters.

4.8 Performance requirements:

When valves are assembled to each other or to components conforming to other parts of EN 1555, the joints shall conform to EN 1555-5.

4.9 Allowable pressure drop shall be as per the standard ISO 17778.

4.10 Color of valve shall be black.

5.0 MATERIAL

5.1 The PE compound from which the valve body with electrofusion socket is made shall conform to EN 1555-1.

5.2 The PE compound of the valve shall be made only from virgin material conforming to EN 1555-1. PE compound shall be cadmium free pigment compound.

5.3 All parts of the valve in contact with the gas stream shall be resistant to the gas, its condensates and other occurring substances such as dust.

5.4 The PE valves bodies made from below listed material are forbidden:

- a) Use of recycled materials

- b) Mixture of different materials
- c) Addition of complementary materials

5.5 The material and constituent elements used in marking of valve (including elastomers, greases and any metallic part, if used) shall be resistant to the external and internal corrosion and shall have life expectancy under following conditions at least equal to the PE pipes with which they are intended to be used.

- a) During storage
- b) Under the effect of the gas conveyed
- c) With respect to the services environment and operating conditions

5.6 The seals shall be homogeneous without any inner cracks, inclusion or impurities. It can not contain any component that can alter the properties of the materials they are in contact with.

- a) The nitrile rubber ring shall comply with standard EN 682.
- b) Other seals shall comply with the relevant standard and be suitable for gas service.

5.7 Operating key or extension spindle shall be made of PVC and non-corrosive.

6.0 DESIGN

6.1 Valve will be designed for a maximum operating pressure (MOP) equal to 10 barg.

6.2 The wall thickness of the PE valve body shall be equal or greater than the minimum wall thickness of the corresponding SDR 11 series pipes.

6.3 Valve shall be bi-directional.

6.4 Specified End to End dimension in the Data-Sheet is minimum requirement.

6.5 The design of valve shall be such that, when assembling the valve into the pipe or other components, the electrical coil and/ or seals or any other ancillary parts are not displaced.

6.6 Valve ends shall have extended pipes at both plain ends. Pressure rating and thickness of extended pipes shall be compatible with the pipe in the network.

6.7 Valve ends shall be welded to pipes or fittings by means of electrofusion jointing using coupler.

6.8 Electrofusion socket shall have sufficient fusion compatibility to the pipe to which it is fused to meet the requirement of standard EN 1555-4 and EN1555-5.

6.9 PE valves bodies and their PE electrofusion socket / ends shall have a pressure rating of at least that of the pipe to which they are assembled.

- 6.10 Valve body and valve ends shall not be bolted and screwed and shall also designed that it cannot be dismantled.
- 6.11 Operating Cap/ Head of valve shall be "non-blow out" type. Size of operating cap shall be 50 mm square socket and 40 mm height as per EN 1555-4.
- 6.12 The running torque of valve shall be as per standard EN 1555-4. Valve shall be designed in such a way that it cannot be easily operated by hand.
- 6.13 Operating Key or Extension spindle shall be provided for valve operation as per client requirement. Operating key or extended spindle shall be compatible with operating cap.
- 6.14 The valve should be equipped with a base plate. In order to achieve this, the valve body will be designed with a flat base or with an attached base plate or an integrated one.
- 6.15 The operating mechanism and the stop wedges will be protected against water intrusion.
- 6.16 The valve body is completely sealed except a passage for the spindle mechanism.

7.0 DIMENSIONS & TOLERANCE

- 7.1 The dimensions will be in conformity with the standard EN 1555-3 and EN 1555-4.
- 7.2 Dimensions shall be measured in accordance with ISO 3126 at (23 ± 2) OC, after being conditioned for at least 4 hrs. The measurement shall not be made less than 24 hrs after manufacture.
- 7.3 Each valve shall be characterized by its dimensions and associated end connections.
- 7.4 Technical data given by the manufacture shall include at least following information:
- a) the dimensional characteristics, by working drawings
 - b) the assembly instruction
- 7.5 The dimensions of electrofusion socket shall conform to EN 1555-3, Table-1.
- 7.6 Pressure rating or thickness of ends shall confirm to interconnecting pipes specification.
- 7.7 Tolerance for operating cap of valve shall be $(50+0.5)$ mm square for socket and (40 ± 2) mm for height.

8.0 DOCUMENT REQUIREMENT

8.1 TO BE SUBMITTED ALONG WITH BID

All relevant documents like detailed technical catalogue, technical deviations list (if any) along with quoted price.

8.2 TECHNICAL FILE

The manufactures of the valves-shall deliver for each type of valve a technical file which includes:

- a) Raw material used.
- b) Drawings, dimensions and tolerances, including for the accessories.
- c) Application range (temperature and pressure limits).
- d) Running torque and initiating torque.
- e) Pressure drop and flow diagram.
- f) Test results and Data proving the conformity of the valve in accordance with ENI555-4 and ENI555-7.
- g) The pipe elements used during valves testing.
- h) The assembly pipes/valves realized during testing shall be in conformity with the manufactures instructions and the extreme installation conditions.
- i) For the test assembly due consideration should be taken regarding the fabrication tolerances and the variation of the outside ambient temperature.

9.0 QUALITY ASSURANCE PLAN

The Quality Assurance Plan (QAP). Inspection shall be carried out as per **Annexure –II** and the vendor is to submit the plan accordingly. Vendor to submit their own QAP along with offer based on indicative QAP enclosed in this tender for approval to the Owner / Owner's representative.

10.0 MARKING

Following information shall be embossed upto height of 0.15 mm onto the valve and also in the form of bar code:

- a) Owner's name as HOGPL.
- b) Manufacturer's name and/or trademark
- c) Material and Designation
- d) Design application series
- e) Nominal diameter
- f) Internal fluid gas
- g) Direction of flow
- h) Traceability code (valve and component) as per standard ISO 12176-4.
- i) Number of the system standard. This information can be printed/formed directly on the valve or on a label associated with the valve or on an individual bag

j) Production period, year and month

The marking shall stay legible during normal manipulation, storage and installation.

The marking shall not adversely influence the performance of the valve and prevent the nonconformity of the valve.

11.0 PACKAGING

The valve and its accessories shall be packaged individually in plastic bags in order to prevent them from deterioration. The valves ends shall be protected with external caps.

The cartons and/or individual bags shall bear at least one label with the manufacturer's name, type and dimensions of the part number, number of units in the box and, any special storage conditions and storage time limits.

SS - ISOLATION
VALVE FOR
SUPPLY OF ISOLATION AND APPLIANCE
VALVES

TABLE OF CONTENTS

1.0	INTENT OF SPECIFICATION	3
2.0	SCOPE OF WORKS	3
3.0	DEFINITIONS	3
4.0	MATERIAL SPECIFICATION FOR ISOLATION VALVES.....	3
5.0	DATA SHEET OF ISOLATION VALVE.....	5

1.0 INTENT OF SPECIFICATION

The intent of this specification is to establish minimum requirements to manufacture and supply of Isolation Ball Valves used for supply of natural gas to domestic & commercial connections.

2.0 SCOPE OF WORKS

The scope of the tenderer will include manufacture/ supply, inspection/ testing/ marking/ packaging/ handling and despatch of Isolation Ball Valves, as indicated in the Material Requisition & Schedule of Rates, meeting all the requirements as laid down in manufacturing standard EN331 (latest edition).

All codes and standard for manufacture, testing, inspection etc. shall be of latest edition.

Owner/ Owner's Representative reserves the right to delete or order additional quantities during execution of order, based on unit rates and other terms & conditions in the original order.

3.0 DEFINITIONS

Owner	Shall mean HPOIL Gas Private Limited (HOGPL)
Manufacturer	Means the Manufacturer of the isolation ball valves
SS	Means the present <<Standard Specification>> and all its appendix, if any.
Third Party Inspection Agency	Means the Inspection Agency to be appointed by OWNER

4.0 MATERIAL SPECIFICATION FOR ISOLATION VALVES

Please Refer Data Sheet

4.1 Markings

Markings shall be provided & shall include:

- i) Manufacturer's name or trade mark, Model designation.
- ii) Rate working pressure in Barg.
- iii) Embossing on valves shall be "**EN 331**" only.

4.2 Packaging

Packing size to be mentioned to ensure uniformity in delivery conditions of the material being procured. Packing size shall be approved by owner / owner's representative before packing the material. Bidder shall submit the packaging details during offer and also complied with at the time of delivery.

4.3 Gas Tightness

Valves shall be leak tightness tested in closed position and shall not leak to atmosphere in open and closed position when subjected progressively to internal air pressure of first 0.006 barg and then to at least 1.5 times the maximum operating pressure (MOP) of the valve. This test shall be performed as per EN331 (latest edition).

4.4 Temperature resistance test

This test shall be carried out as per EN331 (latest edition).

4.5 Mechanical Strength

- i) The body of the valves shall be capable of withstanding, without deformation or leakage, a min. torque as per EN331 (latest edition) as applied to a pipe being connected to the valve.
- ii) Valve shall be capable of withstanding, without deformation or leakage, a min. bending moment as per EN331 (latest edition) as applied to a pipe being connected to the valve.
- iii) The valves shall be capable of withstanding impact without breakage or leakage as per EN331 (latest edition).
- iv) Vendor shall submit Model Number along with catalogues in English language along with un-priced bids.
- v) Maximum turning torque to operate the valve as per EN331 (latest edition).

DATA SHEET OF ISOLATION VALVE

S.NO	DESCRIPTION	DATA	
1.00	PROCESS DATA		
1.01	Fluid	Natural Gas	
2.00	Operating condition		
2.01	Pressure	4 bar (g)	
2.02	Temperature (°C)	0 - 45	
3.00	Design condition		
3.01	Pressure	6 bar (g)	
3.02	Temperature (°C)	-5 to 60	
4.00	VALVE DATA		
4.01	Size	½" , ¾" & 1"	1 ½" & 2"
4.02	Type	Isolation Ball Valve, Full Bore with NPT (Confirming to ANSI B1.20.1) Female Threaded Ends (both inlet & outlet) for natural gas application with operating knob and locking arrangement, sealing wire and lead seal (without Key). Valve full open/close position shall be at 90°. The material is required for Domestic Natural Gas Service.	
4.03	Pressure Rating	*	
4.04	End connection	End connection should be NPT Female (conforming to ANSI B1.20.1).	
4.05	Body material	Total body shall be of Forged Brass (ASTM B 283, Alloy UNSC37700) with hard Nickel / Chrome Plated. UTS – Min. 345 Mpa & Elongation 25 %	
4.06	Ball material	Hard Chrome / Nickel Plated (*), Forged Brass (ASTM B 283, Alloy UNSC37700) with Teflon Seat. UTS – Min. 345 Mpa & Elongation 25 %	
4.07	Stem	*	
4.08	Seat & seal	*	
4.09	Fire safe	*	
4.10	Anti blow out	*	
4.11	Antistatic	*	
4.12	Extension stem	NA	
4.13	Operator	Knob and locking arrangement with Butterfly type Handle	Knob and locking arrangement with Lever type Handle
5.00	PAINTING		
5.01	Surface preparation	*	

5.02	Primer	*
5.03	Finish	*
5.04	Insulation	*
6.00	TEST	
6.01	Hydrostatic Shell Test	
	Test Pressure	7.8 bar(g)
	Test Medium	*
6.02	Hydrostatic Seat Test	
	Test Pressure	*
	Test medium	*
6.03	Functional / Pneumatic Test	
	Test Pressure	7.8 bar(g)
	Test medium	Air
6.04	Tensile Strength Test	As per EN331 (latest edition)
6.05	Bending Test	As per EN331 (latest edition)
6.06	Torque Test	As per EN331 (latest edition)
6.07	Turning Torque Test	As per EN331 (latest edition)
6.08	Antistatic Test	*
6.09	Fire Test	*
6.10	Visual and dimensional examination	As per QAP
Note	Unless otherwise stated all tests will be witnessed by the purchaser	
7.00	QUALITY CONTROL	
7.01	Material certificates	EN-10204, 3.2 Certificate
7.02	All testing certificates	*
8.00	NICKEL-CHROME PLATING	
8.01	Body, Ball etc.	* (Note-3)

NOTE:

1. All Tests shall be carried out as per EN-331 (Latest Edition).
2. Data / Information as marked " * " shall be provided by Vendor / Manufacturer for review and approval by Client / PMC.

-
-
3. Nickel-Chrome Plating thickness shall be 10 micron \pm 2 micron on valve body and ball.

SS - APPLIANCE
VALVE FOR
SUPPLY OF ISOLATION AND APPLIANCE
VALVES

TABLE OF CONTENTS

1.0	INTENT OF SPECIFICATION	3
2.0	SCOPE OF WORKS	3
3.0	DEFINITIONS	3
4.0	MATERIAL SPECIFICATION.....	3

1.0 INTENT OF SPECIFICATION

The intent of this specification is to establish minimum requirements to manufacture and supply of Appliance Ball Valves used for supply of domestic natural gas.

2.0 SCOPE OF WORKS

- 2.1. The scope of the tenderer will include manufacture/ supply, inspection/ testing/ marking/ packaging/ handling and despatch of Appliance Ball Valves, as indicated in the Material Requisition & Schedule of Rates, meeting all the requirements as laid down in manufacturing standard EN331 (latest edition).
- 2.2. All codes and standard for manufacture, testing, inspection etc. shall be of latest edition.
- 2.3. Owner/ Owner's Representative reserves the right to delete or order additional quantities during execution of order, based on unit rates and other terms & conditions in the original order.

3.0 DEFINITIONS

Owner	Shall mean HPOIL Gas Private Limited (HOGPL)
Manufacturer	Means the Manufacturer of the Appliance Ball Valves
PTS	Means the present <<Standard Specification>> and all its appendix, if any.
Third Party Inspection Agency	Means the Inspection Agency to be appointed by Owner

4.0 MATERIAL SPECIFICATION

Please refer Data sheet.

4.1 Markings

Markings shall be provided & shall include:

- i) Manufacturer's name or trade mark Model designation
- ii) Rate working pressure in Bar.
- iii) Embossing on valves shall be "EN 331" only.

4.2 Packaging

Packing size to be mentioned to ensure uniformity in delivery conditions of the material being procured. Packing size shall be approved by owner / owner's representative before packing the material. Bidder shall submit the packaging details during offer and also complied with at the time of delivery.

4.3 Gas Tightness

Valves shall be leak tightness tested in closed position and shall not leak to atmosphere in open and closed position when subjected progressively to internal air pressure of first 0.006 barg and then to at least 1.5 times the maximum operating pressure (MOP) of the valve. This test shall be performed as per EN331 (latest edition).

4.4 Temperature resistance test

This test shall be carried out as per EN331 (latest edition).

4.5 Mechanical Strength

- i. The body of the valves shall be capable of withstanding, without deformation or leakage, a min. torque as per EN331 (latest edition) as applied to a pipe being connected to the valve.
- ii. Valve shall be capable of withstanding, without deformation or leakage, a min. bending moment as per EN331 (latest edition) as applied to a pipe being connected to the valve.
- iii. The valves shall be capable of withstanding impact without breakage or leakage as per EN331 (latest edition).
- iv. Vendor shall submit Model Number along with catalogues in English language along with un-priced bids.
- v. Maximum turning torque to operate the valve as per EN331 (latest edition).

DATA SHEET OF APPLIANCE VALVE

S.NO	DESCRIPTION	DATA
1.00	PROCESS DATA	
1.01	Fluid	Natural Gas
2.00	Operating condition	
2.01	pressure	4 bar (g)
2.02	Temperature (°C)	0 - 45
3.00	Design condition	
3.01	pressure	6 bar (g)
3.02	Temperature (°C)	-5 to 60
4.00	VALVE DATA	
4.01	Size	1/4"
4.02	Type	Appliance Ball Valve, Full Bore with NPT (Confirming to ANSI B1.20.1) Female Threaded End as an inlet and the outlet shall be having Ni/Cr plated brass or stainless steel nozzle (Serrated to suit 1/4" rubber tubing / hose connection and with a metallic operating knob for full open/close at 90° position. The material is required for Domestic Natural Gas Service.
4.03	Pressure Rating	*
4.04	End connection	End connection at the inlet should be NPT Female (conforming to ANSI B1.20.1) and the outlet shall be having Ni/Cr plated brass or stainless steel nozzle
4.05	Body material	Total body including the nozzle shall be of Forged Brass (ASTM B 283, Alloy UNSC37700) with hard Nickel / Chrome Plated. UTS – Min. 345 Mpa & Elongation 25 %
4.06	Ball material	Hard Chrome / Nickel Plated (*), Forged Brass (ASTM B 283, Alloy UNSC37700) with Teflon Seat. UTS – Min. 345 Mpa & Elongation 25 %
4.07	Stem	*
4.08	Seat & seal	*
4.09	Fire safe	*
4.10	Anti blow out	*
4.11	Antistatic	*
4.12	Extension stem	NA
4.13	Operator	Knob with Butterfly type Handle and without locking arrangement
5.00	PAINTING	

5.01	Surface preparation	*
5.02	Primer	*
5.03	Finish	*
5.04	Insulation	*
6.00	TEST	
6.01	Hydrostatic Shell Test	
	Test Pressure	7.8 bar(g)
	Test Medium	*
6.02	Hydrostatic Seat Test	*
	Test Pressure	*
	Test medium	*
6.03	Functional / Pneumatic Test	
	Test Pressure	7.8 bar(g)
	Test Medium	Air
6.04	Tensile Strength Test	As per EN331 (latest edition)
6.05	Bending Test	As per EN331 (latest edition)
6.06	Torque Test	As per EN331 (latest edition)
6.07	Turning Torque Test	As per EN331 (latest edition)
6.08	Antistatic Test	*
6.09	Fire Test	*
6.10	Visual and dimensional examination	As per QAP
Note	Unless otherwise stated all tests will be witnessed by the purchaser	
7.00	QUALITY CONTROL	
7.01	Material certificates	EN-10204, 3.2 Certificate
7.02	All testing certificates	*
8.00	NICKEL-CHROME PLATING	
8.01	Body, Ball etc.	* (Note-3)

NOTE:

1. All Tests shall be carried out as per EN-331 as per EN331 (latest edition).
2. Data / Information as marked " * " shall be provided by Vendor / Manufacturer for review and approval by Client / PMC.
3. Nickel-Chrome Plating thickness shall be 10 micron \pm 2 micron on valve body and ball.

STANDARD SPECIFICATION
FOR
MEDIUM DENSITY POLYETHYLENE PIPES (MDPE)

TABLE OF CONTENTS

1.0 INTRODUCTION & SCOPE	3
2.0 DEFINITIONS	3
3.0 TERMINOLOGY.....	3
4.0 DESIGN CODES/STANDARDS REFERENCES	4
5.0 RAW MATERIAL GRADE AND PROPERTIES	4
6.0 APPROVED MANUFACTURER FOR RAW MATERIAL (PE-100)	5
7.0 PIPE SIZE/ DIMENSION	5
8.0 TOLERANCE	6
9.0 COLOUR.....	6
10.0 MARKING	6
11.0 QUALITY ASSURANCE PLAN (QAP)	7
12.0 TYPE TEST CERTIFICATE	7
13.0 FINISH / DEFECT LIABILITY	7
14.0 FIRST LOT / FIRST CONSIGNMENT LIABILITY	7
15.0 SUPPLY, PACKAGING, HANDLING TRANSPORTATION AND STORAGE OF PE-100 PIPES	7
16.0 DOCUMENTS TO BE SUBMITTED ALONG WITH BID.....	7

1.0 INTRODUCTION & SCOPE

HPOIL Gas Private limited (HOGPL) consortium of HPCL & OIL has received the authorization from PNGRB vide letter PNGRB vide letter PNGRB/CGD/BID/8/2018/GA/Ambala-Kurukshetra District dated 22/02/2018 and PNGRB/CGD/BID/8/2017/BEC/GA-Kolhapur dated 06/03/2018, to Lay, Build and Operate City Gas Distribution networks in Ambala-Kurukshetra and Kolhapur District. HOGPL (hereinafter referred as Owner), is supplying Piped Natural Gas (PNG) to domestic, commercial and Industrial consumers and Compressed Natural Gas (CNG) to automobiles in Ambala-Kurukshetra and Kolhapur District.

VCS Quality Services Pvt. Ltd. (VCS has been appointed as Project Management Consultant for providing consultancy services for CGD Expansion Project for PNG in Ambala-Kurukshetra & Kolhapur (hereinafter referred as Consultant), by HOGPL

The present document covers the technical specifications for the procurement of medium density "Polyethylene Pipes" The Polyethylene Pipes shall be manufactured, supplied in accordance with IS 14885:2001 Polyethylene Pipes for Supply of Gaseous Fuels or ISO-4437 Buried Polyethylene (PE) for the supply of gaseous fuels metric series specifications.

2.0 DEFINITIONS

Owner	Means HPOIL GAS PRIVATE LIMITED (HOGPL)
Manufacturer	Means the Manufacturer of the PE pipe.
TPIA	Means Third Party Inspection Agency to be appointed by HOGPL

3.0 TERMINOLOGY

- **Maximum Allowable Operating Pressure (MAOP):** The maximum effective pressure of gas in a piping system, expressed in bars, which is allowed in continuous use. It takes in account physical & mechanical characteristics of the components of piping system.

The equation for MAOP = $20 \times \text{MRS}/C \times (S D R - 1)$

- **Minimum Required Strength (MRS) —** Minimum value in MPa, for long-term hydrostatic strength (LTHS) of the material.
- **Nominal Outside Diameter (d_n):** A convenient round number (in millimetres) for reference purposes which is common to all components in all thermoplastic systems ,except for flanges and components which are designated by thread size.
- **Out of roundness (Ovality):** The absolute out of roundness is the difference between the measured maximum outside diameter and the measured minimum outside diameter in the cross - section of pipe.
- **Nominal Wall Thickness(e_n):** The wall thickness in millimetre
Corresponding to minimum wall thickness at any point around circumference of the pipe
- **Resin:** A material (solid or semi-solid) which has a high molecular weight and is a product of polymerization.
- **Melt Flow Rate (MFR):** is a value relating to the viscosity of the molten material at a specified temperature and a rate of shear.

- **Standard Dimension Ratio (SDR).** The ratio of nominal outside diameter of a pipe to its nominal thickness.

For any other terminology, IS-14885-2001 (latest) and/ or other applicable National International codes/Standard can be referred.

4.0 DESIGN CODES/STANDARDS REFERENCES

The following National & international codes/ standards/ references (Latest edition) shall be applicable for PE-100 material as well as Polyethylene pipe.

ISO-14885	Polyethylene pipes for supply of Gaseous Fuels
ISO-4437	Buried Polyethylene pipe for supply of Gaseous fuels – metric Series-Specification
IS-2530	Methods of test for PE moulding materials and PE compound
ISO-11830	Plastic: Methods for determining the density of non-cellular plastic
ISO-1872- 28	Plastic: polyethylene (PE) moulding and extrusion material.
ISO- 527	Plastics: Determination of tensile properties.
ISO-1133	Plastics - determination of the melt-mass flow rate (MFR) and melt volume flow rate (MVR) of thermoplastic.
EN 1555-7	Gaseous fuels supply polyethylene (PE)

5.0 RAW MATERIAL GRADE AND PROPERTIES

- Raw material grade classification shall conform to Cl.4.2.1 of IS-14885: 2001.
- The raw material of polyethylene pipes shall be PE 100. The properties of PE-100 shall conform to the table 2 of IS-14885: 2001.
- Other materials /additives such as, anti oxidant, UV stabilizer, pigment dispersion etc. shall conform to IS-14885: 2001.
- Raw material of polyethylene pipes shall be of virgin quality. PE compound shall be Cadmium free pigment compound.
- Anti oxidant & UV stabilised used in PE resin shall not exceed 0.3 and 0.5 % by mass of Finished resin respectively.
- Raw material supplier to supply the certificate for percentage use of U.V. stabilizer in the raw materials (PE compound).
- **Properties of PE-100**

Property	Unit	Test Method	PE100
Conventional Density	Kg/m ³	IS-14885 : 2001 I IS 7328	>= 928.4 at 23°C >= 930.0 at 27°C
Tensile yield strength	MPa	IS-14885: 2001	15, minimum.
Elongation at	%	IS-14885: 2001	350 , minimum

Melt-mass Flow Rate	g /10 min.	IS-2530 I IS-14885: 2001	+/- 20% of value nominated by compound producer@ 190°C I 5.0 kg. (load)
Thermal stability	Minute	Annexure-D of IS-14885-2001	>= 20@ 200°C
Oxidation Induction time	Minute	IS-14885: 2001	>20
Volatile Matter Content	(mg/kg)	IS-14885: 2001	<= 350
Pigment Dispersion		IS-14885 : 2001	<3
Resistance to gas	h	IS-14885: 2001	>=20@ 100°C

The above requirements are also same for the final product.

- PE compound quality evaluation
- PE compound quality evaluation shall be as per IS-14885: 2001.

6.0 APPROVED MANUFACTURER FOR RAW MATERIAL (PE-100)

1. INEOS
2. BOREALIS
3. TOTAL PETROCHEMICALS
4. DOW
5. BASSELL
6. BOROUGE

7.0 PIPE SIZE/ DIMENSION

- Wall Thickness

SI NO	NOMINAL DIA.	MINIMUM WALL THICKNESS, (e)mm	SDR	OVALITY
1	20	3.0	11	IS-14885: 2001

- Length of Pipes

The required minimum length of straight pipes and coils I reels shall be as Follows:

Nominal Diameter(mm)	Packing Length (m)	Straight Length (m)
----------------------	--------------------	---------------------

20	200, Roll	
----	-----------	--

- Method of Measurement

The method of measurement of outside diameter, wall thickness, length, ovality etc. of pipe shall conform to IS-14885: 2001 or equivalent code/standards.

8.0 TOLERANCE

- ❖ Tolerances for Random Length of Pipes
 - Tolerances for each rolled pipes - 0/+0.5m
 - Tolerances for each straight pipes - 0/+0.05m
- ❖ Tolerances on Nominal wall thickness at any points of pipe shall be in accordance with IS-14885: 2001 or equivalent codes / standards.

9.0 COLOUR

The pipe shall be of ORANGE colour, when the pipe shall be manufactured from PE-100 grade of raw material.

10.0 MARKING

- ❖ Owner's name as HOGPL to be marked on each pipe.
 - All pipes shall be permanently and legibly marked along their length with a legend, which shall be impressed to a depth of not more than 0.15 mm.
 - Marking details shall be formed in such a way that marking does not initiate cracks or other type of failure and in such a way that with normal storage weathering and processing and permissible method of installation use legibility shall be maintained for the pipe
- ❖ The embossing for yellow pipe shall have black base. Height of character shall be uniform and at least as given below:
 - a) 3 mm for pipe less than 90 mm nominal size.
 - b) 5 mm for pipe greater than 90 mm nominal size.
- ❖ Legend shall be repeated at intervals of 1 m and shall consist of following Information's:
 - a) Manufacturer's identity name or trade name,
 - b) Material and designation
 - c) Batch no. or lot no
 - d) Internal fluid
 - e) SDR
 - f) Reference of standard

11.0 QUALITY ASSURANCE PLAN (QAP)

Vendor to submit their own QAP along with offer based on indicative QAP enclosed in this tender. However, the same QAP shall be submitted for approval to the Owner I Owner's representative.

12.0 TYPE TEST CERTIFICATE

Vendor to submit Type Test Certificates as per IS-14885: 2001 along with the offer.

13.0 FINISH / DEFECT LIABILITY

The internal and external surfaces of the pipes shall generally be smooth, clean and free from cavities and other surface defects, which may affect pipe performance. The pipe ends shall be cut cleanly and square to the axis of the pipe and shall be within the tolerances of ends. Defect liability period shall be 24 months from last date of delivery of pipes.

14.0 FIRST LOT / FIRST CONSIGNMENT LIABILITY

Vendor shall supply 1st Lot / 1st Consignment from their Warehouse / Store subject to following tests of at least one sample from that lot / consignment duly witnessed by Client / PMC's Representative:

- Hydrostatic Strength at 100°C for at least 165 hr. as per Cl. 8.1, IS-14885.
- Elongation at break 350 percent (Min.), as per Cl. 8.7, IS-14885.

15.0 SUPPLY, PACKAGING, HANDLING TRANSPORTATION AND STORAGE OF PE-100 PIPES

Packaging shall be done in Hessian cloth (Jute) with polyethylene sheet wrapped around the pipe to avoid direct sunlight and facilitate out-door storage. Packing size to be mentioned to ensure uniformity in delivery conditions of the pipe being procured Bidder shall submit the packaging details during offer and also complied with at the time of delivery. Manufacturer shall make an arrangement for unloading of pipes at Owner's premises.

16.0 DOCUMENTS TO BE SUBMITTED ALONG WITH BID

All Relevant Documents like BIS Certification, Catalogue Etc. to be Submitted Along With the Bid.

STANDARD SPECIFICATION FOR MEDIUM DENSITY
POLYETHYLENE FITTINGS

TABLE OF CONTENTS

1.0 SCOPE.....	3
2.0 APPLICABLE CODES, SPECIFICATIONS AND STANDARDS	3
3.0 ABBREVIATIONS & TERMINOLOGY	4
4.0 TECHNICAL REQUIREMENTS	4
5.0 MATERIALS.....	7
6.0 DESIGN.....	8
7.0 DIMENSIONS AND TOLERANCES	11
8.0 DOCUMENT REQUIREMENT	15
9.0 QUALITY ASSURANCE PLAN	15
10.0 MARKING	16
11.0 PACKAGING	16

1.0 SCOPE

This specification along with applicable codes and standards describes the minimum requirements for design, selection, manufacture, inspection/ testing and supply of "MDPE FITTINGS".

This specification elaborates the requirements for Electrofusion fittings in the nominal size range 16 mm to 180 mm made from PE compound used with PE pipes for supply of natural gas and to be used at operating pressure 4.0 bar(g) & operating temperature 25°C.

The material grades shall be PE100 and SDR 11.

2.0 APPLICABLE CODES, SPECIFICATIONS AND STANDARDS

EN 1555-1: Plastics piping systems for the supply of gaseous fuels- Polyethylene (PE) - part 1: General

EN 1555-2 / ISO 4437-2 / IS-14885: Plastics piping systems for the supply of gaseous fuels- Polyethylene (PE)

EN 1555-3: Plastics piping systems for the supply of gaseous fuels- Polyethylene (PE) - part 3: Fittings

EN 1555-5, Plastics piping systems for the supply of gaseous fuels -Polyethylene (PE)- Part 5: Fitness for purpose of the system

EN 1555-7: Plastics piping systems for the supply of gaseous fuels- Polyethylene (PE) - part 7: Guidance for assessment of conformity

EN 1716, Plastics piping systems — Polyethylene (PE) tapping tees — Test method for impact resistance of an assembled tapping tee

ISO TR 13950:1997 or latest edition: Plastics pipes and fittings - Automatic recognition systems for Electro fusions

ISO/IEC 16390:1999 or latest edition: Information technology – Automatic identification and data capture techniques – Bar code symbology specification-Interleaved 2 of 5

EN ISO 17778, Plastics piping systems — Fittings, valves and ancillaries' — Determination of gaseous flow rate/pressure drop relationships

EN ISO 1133, Plastics — Determination of the melt mass-flow rate (MFR) and the melt volume-flow rate (MVR) of thermoplastics

EN ISO 3126, Plastics piping systems — Plastics piping components — Measurement and determination of dimensions

ISO 228-1, Pipe threads where pressure-tight joints are not made on the threads – Part 1: Dimensions, tolerances and designation

PNGRB and other referrals in the above applicable codes.

3.0 ABBREVIATIONS & TERMINOLOGY d_n

d_o : Nominal Outside Diameter

e_n : Nominal Wall Thickness

SDR : Standard Dimension Ratio = d_n / e_n

LTHS : Long Term Hydrostatic Strength (at 20°C for 50yrs)

LCL : Lower Confidence Limit – Stress value (MPa) of mean LTHS

MRS : Minimum Required Strength – min. value (in MPa) for LTHS of material

C : Design Co-efficient – As per ISO: 12162 Table-2

σ_s : Design Stress (= MRS/C)

MFR : Melt Mass Flow rate – Value related to viscosity of the molten material at a specified temp. and rate of shear. (expressed in g/10min.)

D_f : De-rating Co-efficient (Refer Table A.1, Annex A – EN 1555-5)

MOP : Maximum Operating Pressure = $(20 \times MRS) / \{(SDR-1) \times C \times D_f\}$

EF : Electrofusion

4.0 TECHNICAL REQUIREMENTS

The design of fittings shall be as per European Standards EN 1555-3 and the complementary particular requirement.

The fittings are intended to be use in gas distribution networks made of PE and Steel/GI pipes.

No component of the fitting shall show any signs of damage, scratches, pitting, bubbles, blisters, inclusions or cracks to an extent that would prevent conformity of the fittings to the requirements of this standard.

Color of the PE parts of fittings shall be black as per PNGRB.

Allowable pressure drop shall be as per the standard ISO 17778.

Any melt exudation shall not cause wire movement in electrofusion fittings such that it leads to short-circuiting, when jointed in accordance with the manufacturer's instructions. There shall be no excessive creasing of the internal surfaces of the adjoining pipes.

Fittings joints shall conform to EN 1555-5 and shall be leak proof.

Electrical characteristics

- a. For voltages greater than 25 V, direct human contact with energized parts shall not be possible when the fitting is in the fusion cycle during assembly in accordance with the instructions of the manufacturers of the fittings and of the assembly equipment, as applicable.
- b. The manufacturer shall state the tolerance on the electrical resistance of the fitting at 23 °C. The resistance shall not exceed the following value: [nom. value \pm 10 %] + 0.1 Ω .
- c. Note: 0.1 Ω is the assumed value of the contact resistance.
- d. The operating voltage of the fittings shall remain 40 +_ 0.5 V.
- e. The surface finish of the terminal pins shall allow a minimum contact resistance in order to satisfy the resistance tolerance requirements. Electrofusion terminal connections shall be as per Annex A of EN 1555-3.

Mechanical characteristics

- a. Fittings shall have mechanical characteristics conforming to the requirements given in Table 4 of standard EN 1555-3.
- b. The technical descriptions of the manufacturer shall include the following information:
 - a) field of application:
 - pipe and fitting temperature limits;
 - pipe series or SDRs;
 - ovality;
 - b) assembly instructions;
 - c) fusion instructions:
 - fusion parameters with limits;

d) data for saddles and tapping tees:

- the means of attachment (tools and/or under clamp);
 - Need to maintain the under clamp in position in order to ensure the performances of the assembly.
- c. Unless otherwise specified by the applicable test method, the test pieces shall be conditioned at (23 ± 2) °C before testing.
- d. Testing of fitting shall be in accordance with the test methods as specified in Table 4 of standard EN 1555-3 using the indicated parameters.
- e. Hydrostatic test pressure and minimum test period shall be as per Table-5 of EN 1555-3.

Physical characteristics

- a. Fittings shall have physical characteristics conforming to the requirements given in Table 7 of standard EN 1555-3.
- b. Thermal stability test shall be done at 200 deg. C by means of differential scanning calorimetry (DSC), considering oxygen induction time (OIT) ≥ 20 min.
- c. Melt mass flow rate shall be calculated at 190 deg. C by applying 5 Kg of load on test specimen. It shall be expressed in g/ 10min.
- d. Unless otherwise specified by the applicable test method, the test pieces shall be conditioned at (23 ± 2) °C before testing.
- e. Testing of fitting shall be in accordance with the test methods as specified in Table 7 of standard EN 1555-3 using the indicated parameters.

Performance requirements

When fittings are assembled to each other or to components conforming to other parts of EN 1555, the joints shall conform to EN 1555-5.

In case of wall thickness design different from that according to Table-2 of EN 1555-3, fittings and associated joints shall additionally meet the performance requirement listed in Table-6, EN 1555-3.

Electro Fusion Fitting Jointing

- a) For Electro Fusion fitting jointing an electrical resistance element is incorporated in the socket of fitting which when connected to an appropriate power supply, melts and fuses the materials of the pipe and fitting together.

- b) The effectiveness of this technique depends on attention to the preparation of the jointing surfaces, in particular the removal of the oxidized surface of the pipe over the socket depth and ensuring the jointing surface are clean. If ovality causes gap between concentrically located pipe and the fitting to exceed 1% of the pipe OD after re-rounding to ensure correct welding. If the gap still exceeds 1% of the pipe OD after re-rounding then a check should be made of the pipe OD dimensions to determine if it meets specification.
- c) The maximum gap between eccentrically located pipe and fitting i.e. pipe touching fitting at one point must not exceed 2% of the pipe OD.
- d) Sometimes coiled pipes may be too oval to fit into couplers, or the end of the pipe may make the alignment of the ends impossible. In such circumstances the use of a mechanical pipe straightener or rounding tool is necessary.

Electro-Fusion Saddle Jointing

- a) For Electro Fusion fitting jointing an electrical resistance element is incorporated in the socket of fitting which when connected to an appropriate power supply, melts and fuses the materials of the pipe and fitting together.
- b) The effectiveness of this technique depends on attention to the preparation of the jointing surfaces, in particular the removal of the oxidized surface of the pipe over the socket depth and ensuring the jointing surface are clean.
- c) Method of holding the tapping tee saddle during the fusion cycle are used namely top loading and under clamping space around the pipe. In a trench a minimum clearance of 150 mm is required.

Conditioning Period

Refer below table (Table-1 of ISO 11413) for minimum conditioning required for joints.

Nominal wall thickness, <i>en</i> Mm	Minimum conditioning period H
$en < 3$	1
$3 \leq en < 8$	3
$8 \leq en < 16$	6
$16 \leq en < 32$	10
$32 \leq en$	16

5.0 MATERIALS

- 5.1 The PE compound from which the fittings with electrofusion socket are made shall conform to EN 1555-1.

- 5.2 The PE compound of the fittings shall be made only from virgin material conforming to EN 1555-1. PE compound shall be cadmium free pigment compound.
- 5.3 All parts of the fittings in contact with the gas stream shall be resistant to the gas, its condensates and other occurring substances such as dust.
- 5.4 The PE fittings made from below listed material are forbidden:
- Use of recycled materials
 - Mixture of different materials
 - Addition of complementary materials
- 5.5 The material and constituent elements used in marking of fittings (including elastomers, greases and any metallic part, if used) shall be resistant to the external and internal corrosion and shall have life expectancy under following conditions at least equal to the PE pipes with which they are intended to be used.
- During storage
 - Under the effect of the gas conveyed
 - With respect to the services environment and operating conditions
 - Fittings material in contact with the PE pipe shall not adversely affect pipe performance or initiate stress cracking.
- 5.6 All metal parts susceptible to corrosion shall be adequately protected.
- 5.7 When dissimilar metallic materials are used which can be in contact with moisture, steps shall be taken to avoid the possibility of galvanic corrosion.
- 5.8 Greases or lubricants shall not exude onto fusion areas, and shall not affect the longterm performance of fitting materials. Other materials conforming to 4.2.1 of EN 1555-3 may be used provided that it is proven that the fittings conform to this standard.

6.0 DESIGN

Fittings shall be designed for system operation at the pressures given in below table.

Material	M.R.S. MPa	LCL (20°C, 50Yrs 97.5%) MPa	Maximum Allowable Operating Pressure	Operating Voltage
PE 100	10.0	$10.00 \leq \text{LCL} \leq 11.19$	7.0 bar	40 \pm 0.5V

Fittings shall be free from cracks, voids, blisters, distortion, dent or other defects.

Fittings shall be capable of being fusion jointed to pipes using control boxes. The fittings shall exhibit the strengths and fusion compatibility with pipes of respective sizes.

Each fitting shall be bar coded which shall conform to ISO/TR 13950:1997 & ISO/IEC 16390:1999 or latest edition's and shall have a permanent fusion indicator.

Heating coil design shall be such that it should not be damaged during assembly leading to short circuit of heating coil.

6.1 Electrofusion Jointing:

PE pipes, fittings and valves intended to be used for jointing by electrofusion shall be prepared and assembled in accordance with ISO 11413. The conditions for the preparation of the joints are given in clause 4.2.3 of EN 1555-5 for the assessment of fitness for purpose of electrofusion joints.

For joints with electrofusion saddle fittings, the electrofusion saddle fitting shall be fused to the pipe, while it is pneumatically pressurized to the allowable maximum operating pressure. The pipe shall be cut immediately after the manufacturer prescribed cooling time has elapsed.

These joints with electrofusion saddle fitting should be prepared taking into consideration national safety regulations.

For straight equal electrofusion socket fittings (couplers) test joints on selected diameters out of the product range shall be prepared with a gap of $0.05d_n$ between the pipe end and the maximum theoretical depth of penetration of the fitting, where for diameters greater than 225 mm the adjoining pipes shall be arranged to provide the maximum angular deflection possible for the fitting, limited to 1.5° .

6.2 Electrofusion Socket Fittings

Electrofusion Socket Fittings shall incorporate a method of controlling pipe penetration within each socket. The inner cold zone of each socket shall not be less than $(0.1 d + 5)$ mm for sizes upto 125 mm & $0.1 d$ for sizes greater than 125 mm.

Depth of penetration (L1) and Fusion zone length (L2) shall be as per figure-1 & Table-1 (Clause 7.1) of SS.

- a) Elbow/Bends: Both ends of Elbow/Bends shall be electrofusion type with integral stop.
- b) Coupler: Both ends of coupler shall be electrofusion type with integral stop.
- c) Reducer: Reducer ends shall be electrofusion type with integral stop.
- d) Cap: Caps shall be electrofusion end type for leak proof termination of line.
- e) Equal Tee: Main/Header ends of tee shall be electrofusion type. Branch end shall be plain.

6.3 Tapping Tees & Saddles

Tapping Tees and Saddle shall be Wrap Around type for branch connection for ensuring proper alignment and better fusion process.

The tapping tees shall provide a means of cutting through the pressurized main pipe and allowing the gas flow into the outlet pipe. Internal cutter shall be of SS material.

Branch End shall be plain.

Dimensions H, H1, H2 and L shown in figure 2 of SS shall be as per manufacturer standard.

6.4 Transition Fittings

Transition fitting shall be seal tight, pull out resistant and have greater tensile value than that of PE part.

Ends for transition fittings other than electrofusion shall be as per below requirement:

Table – A1

Transition	Size	PE End	Steel / GI End Connection	Min. Length (mm) End to End	Min. Req'd. Steel Length for BE
PE to SS	20mm x 1/2"	EF	Threaded End	80	-
PE to GI	32mm x 3/4"	EF	Threaded End	80	-
PE to CS	32mm x 1"	EF	Threaded End	80	-
PE to CS	63mm x 2"	Plain End	Bevel End	470	400
PE to CS	125mm x 4"	Plain End	Bevel End	570	480
PE to CS	180mm x 6"	Plain End	Bevel End	590	485

6.5 PE Pipes to Bevel Ends

To make connection between steel pipe and MDPE pipe, specially fabricated transition pieces consisting of Steel and MDPE pipes should conform to the following requirements:

- a) MDPE pipe with one end plain should conform to the specification (EN 1555-2 / ISO 4437-2 / IS-14885/ SDR 11).
- b) MDPE end shall be compatible (thickness/ nominal size) to the interconnecting PE pipes of the network.
- c) Steel end (CS/SS) shall be compatible (grade of material/ thickness/ nominal size) to the interconnecting steel pipes of the network.
- d) Steel end of the fitting should be beveled for welding. Angle of bevel should be 30° + 5°.
- e) Steel and MDPE pipes should be so jointed in the factory so as to have a monolithic joint which is leak free and should be mechanically as strong as or stronger than the PE Pipe.

- f) Minimum required length of steel for transition fitting is specified in Table A1. Vendor to provide adequate length so that the PE part of the fitting / pipe will not get effected during welding at site.
- g) Joint between metallic and non-metallic part of transition fitting shall be leak-proof.

6.6 PE Pipes to Threaded Ends

- a) Transition fitting for jointing of MDPE Pipes conforming to specification SDR 11, IS: 14855/ ISO: 4437/ EN1555-2.
- b) The transition fittings shall be electrofusion type for PE connection, NPT Female threading conforming to ANSI B 1.20.1.
- c) Steel end (CS/SS) / GI shall be compatible (grade of material/ thickness/ nominal size) to the interconnecting pipes of the network.
- d) Joint between metallic and non-metallic part of transition fitting shall be leak-proof.

7.0 DIMENSIONS AND TOLERANCES

Dimensions shall be measured in accordance with EN ISO 3126 at (23 ± 2) °C, after being conditioned for atleast 4 h. The measurement shall not be made less than 24 h after manufacture.

7.1 For Electro Fusion Socket Fittings

For electrofusion sockets (see Figure 1) having a nominal diameter given in Table-1, the socket diameter and lengths shall be given by the manufacturer and shall conform to Table 1 with the following conditions:

- a) $L_3 \geq 5 \text{ mm}$;
- b) $D_2 \geq d_n - 2e_{\text{min}}$

Where,

e_{min} is the minimum wall thickness specified for the corresponding pipe conforming to EN 1555-2;

D_1 is the mean inside diameter in the fusion zone measured in a plane parallel to the plane of the mouth at a distance of $L_3 + 0.5L_2$ from that face;

D2 is the bore, which is the minimum diameter of the flow channel through the body of the fitting;

L1 is the depth of penetration of the pipe or male end of a spigot fitting. In case of a coupling without stop, it is not greater than half the total length of the fitting;

L2 is the heated length within a socket as declared by the manufacturer to be the nominal length of the fusion zone;

L3 is the distance between the mouth of the fitting and the start of the fusion zone as declared by the manufacturer to be the nominal unheated entrance length of the fitting.

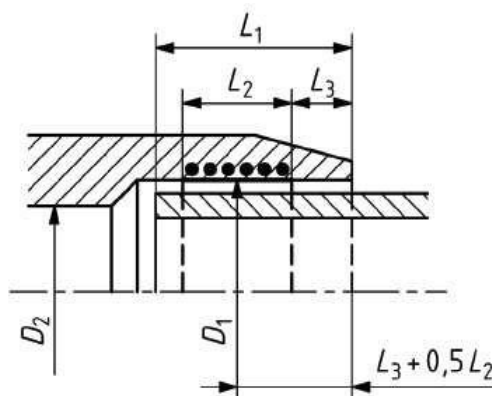

Figure 1 — Dimensions of electrofusion socket fittings

The mean inside diameter of the fitting in the middle of the fusion zone (see L1 in Figure 1) shall be not less than d_n .

Table - 1

Nominal Diameter r d_n (mm)	Depth of Penetration L_1 , min.			Fusion Zone L_2 , min.
	Intensity Regulation L_1 , max.	Voltage Regulation		
16	20	25	41	10
20	20	25	41	10
25	20	25	41	10
32	20	25	44	10
40	20	25	49	10
50	20	28	55	10
63	23	31	63	11
75	25	35	70	12
90	20	25	41	10
110	32	53	82	15

125	35	58	87	16
140	38	62	92	18
160	42	68	98	20
180	46	74	105	21

The manufacturer shall declare the actual minimum and maximum values of D1 to allow the end-user to determine their suitability for clamping and joint assembly and fitness for purpose testing in accordance with EN 1555-5.

In the case of a fitting having sockets of differing nominal diameters, each one shall conform to the requirements for the nominal diameter of the corresponding component.

7.2 Wall Thicknesses

In order to prevent stress concentrations, any changes in wall thickness of the fitting body shall be gradual.

- a) The wall thickness of the body of the fitting at any point, E , shall be greater than or equal to e_{min} for the corresponding pipe at any part of the fitting located at a distance beyond a maximum of $2L_1/3$ from all entrance faces if the fitting and the corresponding pipe are made from a polyethylene having the same MRS.

If the fitting is produced from a polyethylene having an MRS that is different from that of the corresponding pipe, the relationship between the wall thickness of the fitting, E , and the pipe, e_{min} , shall be in accordance with Table 2.

Table 2 — Relation between fitting and pipe wall thicknesses

Pipe and fitting material		Relation between fitting wall thickness, E , and pipe wall thickness, e_n
Pipe	Fitting	
PE 80	PE 100	$E \geq 0,8e_n$
PE 100	PE 80	$E \geq e_n/0,8$

- b) In the case of a wall thickness design different from that according to a), fittings and associated fusion joints shall additionally meet the performance requirement given in Table 6 of EN 1555-3.
- c) When a fitting leaves the site of the manufacturer, the out-of-roundness of the bore of a fitting at any point shall not exceed $0.015dn$.
- d) The dimensional characteristics appropriate to each manufacturer such as the overall dimensions or mounting dimensions shall be specified in a technical file.

7.3 For Electro Fusion Saddle Tapping Fittings

Outlets from tapping tees and branch saddles shall have an electrofusion socket conforming to Clause 7.1 of SS.

The manufacturer shall specify the overall dimensions of the fitting in a technical file. These dimensions shall include the maximum height of the saddle, H , and for tapping tees the height of the service pipe, H_1 or H_2 (see Figure 2).

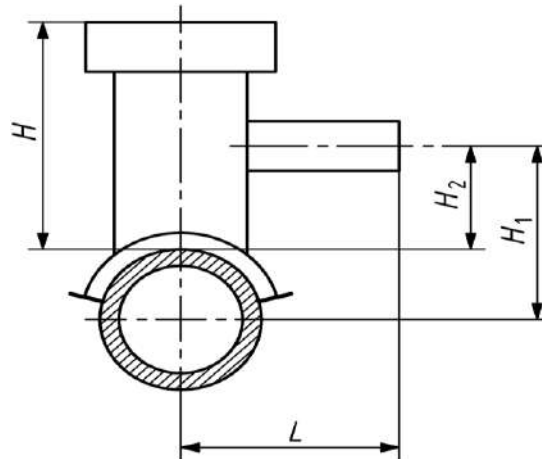

Figure 2 — Dimensions of electrofusion saddle fittings

Where,

- H height of the saddle, which comprises the distance from the top of the main pipe to the top of the tapping tee or saddle
- H_1 height of service pipe, which comprises the distance from the axis of the main pipe to the axis of the service pipe
- H_2 height of service pipe, which comprises the distance from the top of the main pipe to the axis of the service pipe
- L width of the tapping tee, which comprises the distance between the axis of the pipe and the plane of the mouth of the service tee

7.4 Dimensional Stability:

Couplers (including all forms of socket fittings):

All coupler dimensions shall conform to their specified value when the fitting has been stored for a period of 12 months at a temperature of $30 \pm 2^\circ\text{C}$.

Tapping Tees and Branch Saddle:

All tapping tee and branch saddle dimensions shall conform to their specified agreed

values when the fitting has been stored for a period of 12 months at a temperature of 30 + 2°C.

8.0 DOCUMENT REQUIREMENT:

8.1 To Be Submitted Along with Bid

All relevant documents like detailed technical catalogue, technical deviations list (if any) along with quoted price.

8.2 Technical File:

The manufacturer of the fittings shall make availability of a technical file (generally confidential) with all relevant data to prove the conformity of the fittings to this specification. It shall include all results of the type testing and shall conform to the specification relevant technical brochure (e.g. ISO 12093 for electro fusion fittings).

The technical description of the manufacturer shall include the following information:

- a) Field of appliance (pipe and fitting temperature limits SDR's and out of roundness).
- b) Assembly instructions.
- c) Fusion instruction (fusion parameters with limits).
- d) For saddles and tapping tee

The means of attachment (tools and/ or under clamp).

The need to maintain the under clamp in position in order to ensure the performances of the assembly.

For electrofusion fitting, the format of the technical brochure shall conform to ISO DIS 12093.

In the event of modification of the fusion parameters, the manufacturer shall ensure that the joint conforms to this standard.

9.0 QUALITY ASSURANCE PLAN

The Quality Assurance Plan (QAP). Inspection shall be carried out as per **Annexure – I** and the vendor is to submit the plan accordingly. Vendor to submit their own QAP along with offer based on indicative QAP enclosed in this tender for approval to the Owner / Owner's representative

10.0 MARKING:

Following information shall be embossed upto height of 0.15 mm onto the fitting and also in the form of bar code:

- a) Owner name as HOGPL.
- b) Manufacturer's name and/or trademark
- c) Material and Designation
- d) Design application series
- e) The size of the fitting in mm
- f) Fusion time in seconds
- g) Cooling time in minutes
- h) Fusion parameters in BAR code
- i) Traceability code (fittings) as per standard ISO 12176-4.
- j) Number of the system standard. This information can be printed/formed directly on the fitting or on a label associated with the fitting or on an individual bag
- k) Production period, year and month

The marking shall stay legible during normal manipulation, storage and installation.

The marking shall not adversely influence the performance of the fitting and prevent the nonconformity of the fitting.

11.0 PACKAGING:

The fittings shall be packaged in bulk or individually protected where necessary in order to prevent deterioration. Whenever possible, they shall be placed in airtight plastic bags in card board boxes or cartons.

The cartons and/or individual bags shall bear at least one label with the manufacturer's name, date of manufacturer, type and dimensions of the part, number of units in the box, and any special storage conditions and storage.

STANDARD SPECIFICATION
FOR
HEALTH, SAFETY & ENVIRONMENT

Contents

1.	SCOPE	3
2.	APPLICABLE SYSTEMS AND PROCEDURES	3
3.	REFERENCES	4
4.	RESPONSIBILITY & ORGANISATION	4
5.	GENERAL REQUIREMENT	4
6.	TRAINING	5
7.	TOOL BOX TALKS	5
8.	INCIDENT/ACCIDENT AND NEAR-MISS REPORTING, INVESTIGATION AND FOLLOW UP	5
9.	HAZARD IDENTIFICATION AND RISK ASSESSMENT SYSTEM (HIRA)	6
10.	SITE HSE INSPECTION/AUDIT	6
11.	FIRST AID FACILITY	7
12.	FITNESS TO WORK	8
13.	PERSONNEL PROTECTIVE EQUIPMENTS	9
14.	EQUIPMENT LIST AND INSPECTION CERTIFICATE	11
15.	HSE REQUIREMENTS AT SITE	11

1. SCOPE

This specification establishes the Health, safety and Environment (HSE) aspects to be complied with by the contractor during construction at site.

2. APPLICABLE SYSTEMS AND PROCEDURES

The reference standard for setting Quality, Health, Safety and Environment Systems and procedures will be as linked below –

- Guidelines issued by PNGRB.
- ISO 9001 – 2008 - For Quality System.
- ISO 14001 – 2004 - For Environmental Management System
- (OSHAS) 18001-2007 -For occupational health and safety management Systems.

The Occupational Health & Safety Assurance Standard (OHSAS) 18001-2007 gives requirements for an occupational health and safety (OH&S) management system. It enables an organization to control its OH&S risks and improve its performance. It provides a basis for an organization to specify its OH&S performance criteria and design the management system.

OHSAS 18001 is compatible with the ISO 9001 (Quality) and ISO 14001 (Environmental) management systems standards. This facilitates integration of quality, environmental and occupational health and safety management systems by an organization.

Organization structure of the proposed CGD project includes a position for developing, installing and maintaining (with assistance by a specialist entity) Quality Assurance (QA) and Health, Safety and Environment (HSE) systems in line with ISO 9001-2008, OHSAS 18001-2007 and ISO 14001- 2004 Standards.

Documented Standard Operating Procedures (SOP) will be prepared by the Owner/Owner's representative for CGD entity for QA and HSE, for application across the organization. Development of the SOPs and implementation of the same at construction sites, control rooms, regional and corporate offices will be followed by an internal audit to verify conformance.

The CGD Network operating entity will thereafter regularly monitor, through periodic internal and mandatory external audits, effective implementation of the SOPs at the construction sites, control rooms regional and corporate offices as per systems and procedures.

3. REFERENCES

This document should be read in conjunction with following.

- General Condition of Contract (GCC)
- Special Condition of Contract (SCC)
- Job Specifications
- Relevant IS codes, OSHAS standard
- Reporting Formats

4. RESPONSIBILITY & ORGANISATION

Health, Safety and Environment activities at site shall be under Contractor's scope. Contractor shall be responsible for implementation of HSE provisions. The nominated or designated safety engineer/ officer shall assist and perform day to day HSE work as per his advice.

5. GENERAL REQUIREMENT

- 5.1.** The contractor should follow HSE policy of owner as applicable to construction site.
- 5.2.** The contractor shall ensure that HSE requirements are clearly understood & faithfully implemented at all level, at each site.
- 5.3.** The contractor shall organize safety awareness programs regularly.
- 5.4.** The contractor shall ensure his participation in every HSE meeting called by owner/owner representative.
- 5.5.** The contractor shall conduct daily tool box talk.
- 5.6.** Contractor shall ensure that their safety supervisor must always be present at site.
- 5.7.** Contractor shall take sufficient care in moving his plants, equipment's and materials from one place to another place so that they do not cause any damage to any person or the property of the owner or any third party.
- 5.8.** Working after sunset is strictly prohibited.
- 5.9.** Hygiene requirement must be met on site by providing fresh drinking water at each site
- 5.10.** The contractor shall submit Monthly HSE reports (Form attached in ANNEXURES).

5.11. The contractor shall provide one four wheeler at site during working hour to meet any contingency.

5.12. The contractor shall adhere consistently to all provisions of HSE .In case of non- compliance or continuous failure the owner/ owner representative may impose stoppage of work for the serious HSE violation. All works shall be carried out in presence of Owner/Owner's Representative only.

6. TRAINING

The Contractor duties shall include conducting HSE training for all activities and personnel involved.

The Contractor shall ensure that their Personnel have been given the necessary HSE and work-related skills training in compliance with regulatory requirements prior to engaging the personnel for the work.

7. TOOL BOX TALKS

Contractor's Site Supervisor for specific work location shall conduct a tool box at the commencement of work on daily basis. If different team is working in different area, separate tool box talk covering location and hazard involved shall be carried out.

Each toolbox meeting shall cover the following agenda:

- Discuss safety issues of previous day
- Brief description of activities planned for the day & associated hazard
- Information & resources required to put controls in place
- Location specific hazard and instructions.
- Requirements Open

It is the responsibility of supervisor to convey PPE requirement to all workers and ensure compliance of the same and shall be checked during tool box talk before embarking on work.

Tool box talk report shall be prepared and kept at site within one hour of talk and it must be signed by all attendee to ensure participation of all in the talk. Tool box report shall be submitted to CONSULTANT/ OWNER

8. INCIDENT/ACCIDENT AND NEAR-MISS REPORTING, INVESTIGATION AND FOLLOW UP

8.1. Incident/Accident and Near-Misreporting

All incidents/accidents must be reported immediately. A report should be prepared by the Supervisor and submitted to the Site Manager within 12 hours of the occurrence and shall serve as a source for education of employee to prevent reoccurrence of similar

incident/accident.

Contractor shall submit the Initial report of all Accidents/Incidents within 12 hrs.to Owner / Consultant and detail report within 24 hrs. For serious incidents and near misses, with the potential for fatality, serious injury or significant environmental or material damage, Contractor shall notify Owner/Consultant without delay and within twenty four (24) hours.

8.2. Incident/Accident Investigation

All incidents/accidents must be reviewed and analyzed to establish root causes and type of injury, trends and practices.

Investigation shall begin promptly after the occurrence of the incidents/accidents. The completed incidents/accidents investigation report shall be submitted to the Contractor Site Manager within 7 days of the occurrence. A copy shall be submitted to Owner/Consultant.

8.3. Follow-up

All incidents/accidents, including investigation results and recommendations, shall be discussed in the Site HSE meeting and shall be brought to the notice of employees in toolbox meetings.

Key Risks Identification and Management Risks

Working at height is a critical activity. Following hazards are associated with Working at height:

- Person Fall from height
- Material falling From height
- Slips, trips and falls
- Concealed utilities (i.e. electric cable Telephone cable, water line, Drainage line}
- Electric shock

9. HAZARD IDENTIFICATION AND RISK ASSESSMENT SYSTEM (HIRA)

The Contractor shall prepare and implement comprehensive HIRA as part of the HSE Management Plan prior to Commencement of the work or services and during the execution of the work also.

10. SITE HSE INSPECTION/AUDIT

All Site HSE checklists/Inspection reports shall incorporate a follow-up procedure to ensure that any recorded HSE violations have been promptly attended to in a satisfactory manner.

The Site HSE Inspections/Audit shall be planned by the Contractor.

11. FIRST AID FACILITY

The contractor shall provide the first aid box at all the sites. The content of the first aid box shall include the following items:

- Twenty-four small sterilized dressings.
- Twelve medium size sterilized dressings.
- Twelve large size sterilized dressings.
- Twelve large size sterilized burn dressings.
- Twelve (15 gin) packets of sterilized cottonwood.
- One (200 ml) bottle of certified solution (1 per cent) or a suitable antiseptic solution.
- One (200 ml) bottle of mercurochrome (2 per cent) solution in water. (viii) One (200 ml) bottle of salt-volatile having the dose and mode of administration indicated on the label.
- One pair of scissors
- One roll of adhesive plaster (6 cm x 1in).
- Two rolls of adhesive plaster (2 cm. x 1in).
- Twelve pieces of sterilized eye pads in separate sealed packets.
- One polythene wash bottle (500 cc) for washing eyes.
- Twelve roller bandages 10 cm wide.
- Twelve roller bandages 5 cowhide.
- Six triangular bandages.
- One tourniquet.
- A supply of suitable splints.
- Two packets of safety pins.
- Kidney tray.
- One copy of first-aid leaflet issued by the Directorate General of Factory Advice Service and Labor Institutes, Government of India, Bombay.

All the content shall be kept in clearly marked and easy to remove cartons stored in such a manner that there is no rattling or spilling over even when the container is being moved Whenever applicable the cartons shall bear instructions for use, dosage etc.

12. FITNESS TO WORK

The objective of Medical Assessment for Fitness to Work (FTW) is to assess health of employees in relation to their specific jobs such as working at height, to ensure they could perform required task without risk to health and safety.

The Contractors workers (as per the above category) shall under go through FTW prior to start work at site. It will be the responsibility of the Contractor to ensure compliance to this requirement.

12.1. Medical Examination requirement for working at height

Below specific requirements are must for Medical examination of Contractors employees working at height:

- History of Epilepsy.
- Blood Pressure.
- ECG+ any History of any Seizures.
- Vision Check.
- Blood Sugar (fasting &PP).
- And other general tests.
- Physical Examination- to confirm the person is physically fit.
- Blood Group (One time Test).
- General check about fear of Heights.

12.2. Other Requirements:

- Contractor to ensure that persons involved in working at height are trained, certified and having Valid I Card.
- Carry out tool box talk before starting of the work.
- Carry out site specific risk assessment and identify risk control measures for specific site work. (Ref doc).
- Ensure that persons are physically & mentally fit for working at height.
- Ensure that equipment shall be used as per approved standard for working at height.
- Ensure that equipment shall have facility of emergency rescue operation.
- Ensure person involved in working at height are trained in emergency rescue

operation.

- Ensure that all equipment and safety devices used are inspected, certified by competent authority & valid & suitable for use.
- Quality conformance shall be carried out prior to start of work for working at height equipment's.
- Life cycle of equipment shall be checked
- In case of any part of equipment is found damaged or defective, it will be destroyed. "Working at height equipment's shall never being repaired". The Records, showing reasons for all the defective and damaged material shall be available and shall be stored separately at Contractor's yards.
- Ensure that Personnel Protective Equipment are inspected & in good condition
- Ensure that equipment used is within Safe working load mentioned on equipment.
- Ensure all tools are secured or kept in Tool kit / bag and there are no loose objects or tools.

13. PERSONNEL PROTECTIVE EQUIPMENTS

The contractors shall provide sufficient numbers of following personnel protective equipment's (PPEs) to workmen and supervisors/engineers to use them properly at work site.

Following five numbers of Personnel protective equipment's are identified as MANDATORY for all.

- Safety Helmet
- Coverall
- Safety shoes/footwear
- Safety Glasses
- Hand Gloves (as per job requirement) Other PPEs shall be as per job requirement like Work at height- Full body harness (PETZL or equivalent make), Life line, Safety Net Arc Welding – Welding face shield Grinding –Grinding face shield Height work – Full Body harness (above 2 meters) Contractor to ensure proper use and selection of protective clothing / equipment for specialized jobs.

PPE's to be used shall be as per following Specification:

IS : 2925 – 1984 : Industrial Safety Helmets.

IS : 4770 – 1968 : Rubber gloves for electrical purposes

IS : 6994 – 1973 (Part – I)	: Industrial Safety Gloves (Leather& Cotton)
IS : 1989 – 1986 (Part – I &	: Leather safety boots and shoes
IS : 3738 – 1975	: Rubber knee boots
IS : 5557 – 1969	: Industrial and Safety rubber knee boots
IS : 6519 – 1971	: Code of practice for selection, care and repair of Safety footwear
IS : 11226 – 1985	: Leather Safety footwear having direct molding sole
IS : 5983 – 1978	: Eye protectors
IS : 9167 – 1979	: Ear protectors.
IS : 3521 – 1983	: Industrial Safety belts and harness

Technical Standard for working at height equipment's shall be as per following standard:

Quality Standards

Sr. No.	Name of equipment's	EN Standard
1	Energy absorbers	365
2	Slings	566
3	Retractable type fall arresters	360
4	Guide Type fall arresters on a rigid	353-1
5	Connectors	362
6	Dynamic mountaineering rope	892
7	Descended device	341
8	Anchor device Type-A/B	795
9	Fall arrester harness	361
10	Sit harness	813
11	Lanyards	354
12	Pulleys	12278
13	Fall arrester system	363
14	Work positioning belt	358

14. EQUIPMENT LIST AND INSPECTION CERTIFICATE

Equipment list must be made available and must be certified for safety as per the requirement of Factory Act. Tools and Tackles should be calibrated from the approved agency only.

List of Tools and Tackles

Item	Inspection/Calibration Date
Full body harness	Once in six Month
Rope Grab fall arrestor	Once in six Month
First Aid Box	Once in Month
Fire Extinguisher (10 Kg.)	Once in a Year
Extension board(without cable Joint with Socket) with Circuit Breaker	Monthly
Nylon tie line for tools	Once in a day

15. HSE REQUIREMENTS AT SITE

Contractor may conduct survey to assess the requirement of GI riser for high rise building.

For Work at Height: Contractor shall provide PETZL or equivalent system/metallic

scaffolding as a working platform and full body harness with self-locking arrangement. Full body harness with self-locking arrangement shall be used for ascending/descending/work rest.

PETZL system or equivalent system/metallic scaffold should comply with relevant IS/EN/BS standard.

Only certified trained plumber undergone practical training on work at height shall be deployed.

15.1. Any working at height related activities has to be carried out with Permit system.

Work at Height

Working at Height is performing work at height where workers can fall 1.8m or more from where they stand or sit to perform work. This includes gaining access to working at height if there is a risk of falling 1.8m or more.

Examples of Working at Height are:

- Working on temporary platform more than 1.8mhigh
- Working on top of vehicles/tankers or building more than 1.8 m high Risk of Working at Height
- Fall from height
- Falling objects

Safety net, fall arrest system and two lanyard full body harness when working at height While working at height, all loose tools shall be kept inside a container and good housekeeping shall be maintained.

All Working at Height shall comply with Working at Height Procedures Safety Net System.

"Safety net systems" Safety net systems and their use shall comply with the following provisions.

Safety nets shall be installed as close as practicable under the walking/working surface on which workers are working, but in no case more than 30 feet (9.1 m) below such level. When nets are used on bridges or similar kind, the potential fall area from the walking/working surface to the net shall be unobstructed.

Vertical distance from working level to horizontal plan of net	Minimum required horizontal distance of outer edge of net from the edge of the working surface
Up to 5 feet	8 feet
More than 5 feet up to 10 feet	10 feet.
More than 10 feet	13 feet

- Safety nets shall be installed with sufficient clearance under them to prevent contact with the surface or structures below when subjected to an impact force.
- Safety nets and safety net installations shall be drop-tested at the jobsite after initial installation and before being used as a fall protection system, whenever relocated, after major repair, and at 6-month intervals if left in one place. If drop test not possible designated competent person shall certify that the net and net installation is in compliance with the requirement by preparing a certification record prior to the net being used as a fall protection system. The certification record must include an identification.
- Determined that the identified net and net installation were in compliance and the signature of the person making the determination and certification. The most recent certification record for each net and net installation shall be available at the jobsite for inspection.
- Defective nets shall not be used. Safety nets shall be inspected at least once a week for wear, damage, and other deterioration. Defective components shall be removed from service. Safety nets shall also be inspected after any occurrence which could affect the integrity of the safety net system.
- Materials, scrap pieces, equipment, and tools which have fallen into the safety net shall be removed as soon as possible from the net and at least before the next work shift.
- The maximum size of each safety net mesh opening shall not exceed 36 square inches (230 cm) nor be longer than 6 inches (15 cm) on any side, and the opening, measured center-to-center of mesh ropes or webbing, shall not be longer than 6 inches (15 cm). All mesh crossings shall be secured to prevent enlargement of the mesh opening.
- Each safety net (or section of it) shall have a border rope for webbing with a minimum breaking strength of 5,000 pounds (22.2kN).
- Connections between safety net panels shall be as strong as integral net components and shall be spaced not more than 6 inches (15 cm) apart.

15.6.1 Lifeline

- Horizontal or vertical life line shall be used while working on suspended platform or similar type of platform or working at thereof/edge
- Horizontal/Vertical lifelines shall be designed, installed, and used, under the supervision of a qualified person, as part of a complete personal fall arrest

system, which maintains safety factor of at least two.

- Lanyards and vertical life line shall have a minimum breaking strength of 5,000 pounds (22.2kN).
- When vertical lifelines are used, each worker shall be attached to a separate lifeline.

15.6.2 Full Body Harness

- Ensure that the full body harness must be inspected prior to use.
- Ensure that full body harness must be worn by the workmen while working at height.
- Full body harness lanyard must be anchored with a strong member.
- While climbing up or climbing down, one of the hooks of lanyard must be locked alternatively all the time.

15.6.3 Working Platform

Every working platform more than 1.8 mtr. High from which a person is likely to fall shall be of steel plates/planks/cage and shall be:

- Closely boarded, planked or plated.
- At least 700 mm wide if the platform is used as a footing only and not for the deposit/ keeping of materials.
- At least 900 mm wide if the platform is used for the deposit of materials.
- At least 1100 mm wide if the platform is used for the support of higher platform.
- Two metal/planks shall not have 25 mm gap between them the distance between two consecutive transoms or other supports on which a platform rests shall be fixed with due regards to the anticipated load and the nature of platform flooring. As a general rule such transoms shall not be placed more than 1.0 mtr. apart.

15.6.4 Scaffold

Scaffold Inspector (Project Field Officer)

This is the competent individual who shall inspect scaffolding prior to each use and perform full inspections as per the Inspection procedure. He will accept the Scaffold after ensuring the followings;

- The scaffold erected complies with legislation.

- The permissible loads per deck and the working distance between the scaffold and the work surface are examined.
- Materials used for the scaffold are in a proper condition and in throughout the time it is in place.
- Existence and proper installation of collective protective equipment and means of access.
- Clear display of details of permissible loads on the scaffold.
- Acceptance is carried out prior to the scaffold being made available for the first time and is repeated after any alterations.
- Inspection is repeated at the frequency of 7 days. Issues scaffold tag (Green Tag) before its first use.

Scaffold Contractor

This refers to the company involved in the installation (erection, dismantling and alteration) and/or design of the scaffolding on behalf of CONTRACTOR.

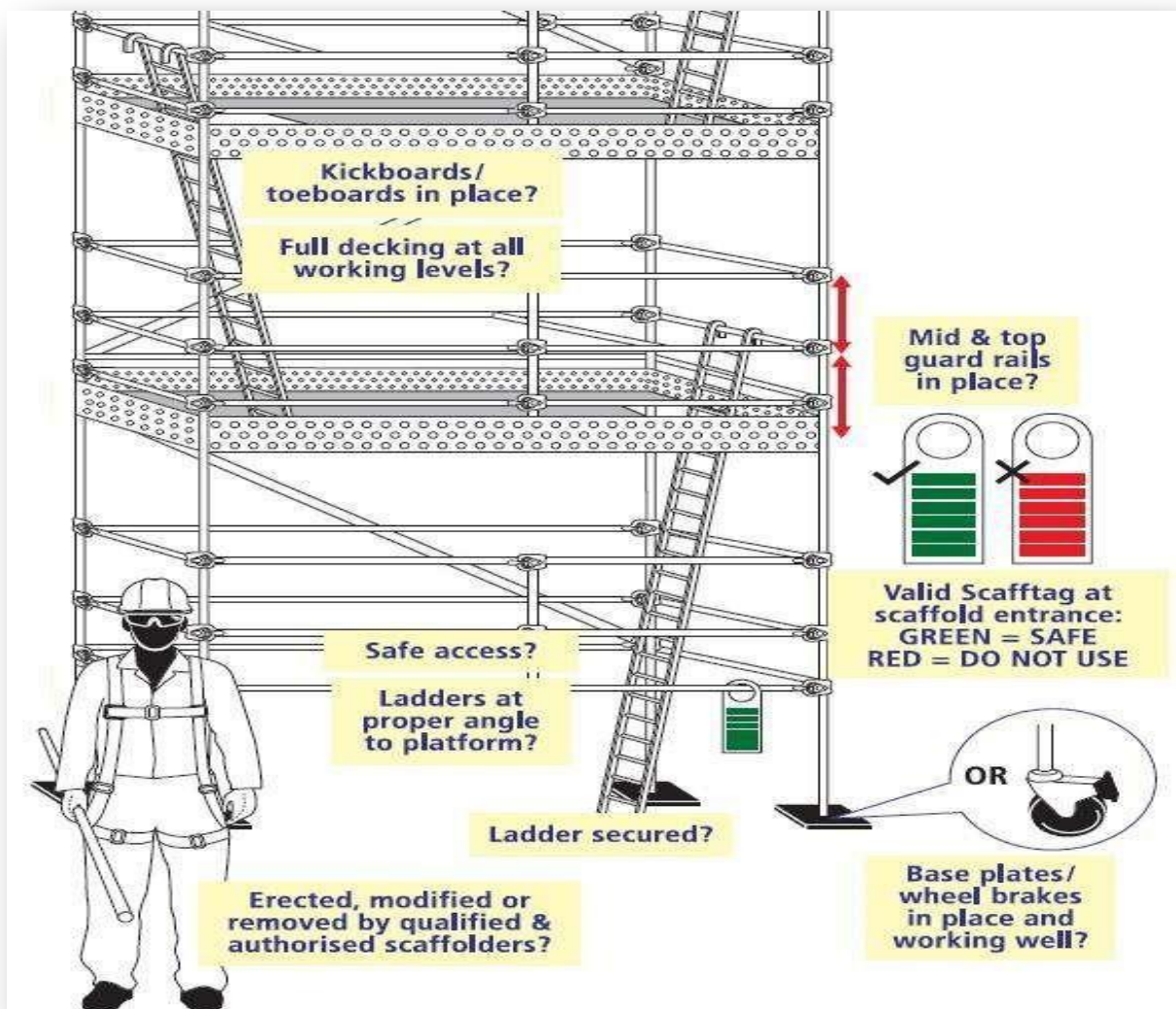

- The erection contractor shall ensure that the scaffolding is erected in compliance with the OHSAS/IS standards. Worksite specifications and considerations shall be incorporated into any such plan.
- Ensure availability of competent staff and certified material all the time.
- Scaffolding may be erected, dismantled or altered only under the supervision of a competent individual who has received adequate specific training for the intended operations, specifically including the following:
 - Understanding the erection, dismantling and alteration plans for the scaffolding
 - Ensure PPEs and Safety at work during erection ,dismantling and alteration of the scaffolding.
 - Measures designed to prevent the risk of falling person's and objects.
 - Safety measures applicable in the event of a change in weather conditions.
 - Permissible structural load criteria.
 - Any other risk that may be entailed by erection, dismantling and alteration operations.
- Scaffold material: Safe handling, and storage.

Scaffold User

- The User shall ensure that acceptance of the scaffold has been properly carried out; green Tag is issued and provide notification of any alterations. Work from tagged scaffolds only. Comply with special conditions/additional controls noted on the access tag.
- It shall observe all restrictions on use (particularly permissible loads). Its requirements should be taken into consideration in the specifications during erection.
- Use scaffolds only for their intended purpose.
- Do not use unstable objects or makeshift devices to increase the working height of the scaffolds.
- Use portable ladders as a means of increasing the working height only after the competent person has determined that the stability of the structure has not been compromised, and adequate fall protection is in place.

- Do not straddles, stand on, or work outside of the guardrail.
- Use designed access means to descend or ascend a scaffold (stairs, attached ladder, or specially designed end frames). Do not use cross bracing or side rail
- Keep only the tools and materials on the platform that are necessary to perform the task. Control all slipping and tripping hazards by removing or securing the tools/materials.
- Do not modify or remove a scaffold system/component or status tag.
- Notify supervision immediately if a scaffold is damaged, weakened, or otherwise deficient.
- Scaffold users/ Scaffold erectors shall use IS and EN standard double lanyard safety harness with absorbent.

Inspection Points

To ensure the integrity and proper installation of scaffolding, a certain number of points shall be inspected. Inspection of these points ensures a basic level of safety. Following fundamental inspection points are as follows:

- Environment and location
- Supports and soleplates
- Structure and posts
- Decks
- Scaffold Capacity Standards
- Working levels
- Access
- Signs and signage

Mobile Scaffolding

- Mobile scaffolds are identical in design to fixed scaffolds, except that their tubular structure is lighter and in terms of support, the wheels do not offer the same load-bearing area as footplates on fixed scaffolds.
- Erection is simple and shall be carried out using personal protective equipment. Lastly, during erection, dismantling and use, the brakes shall also be applied. Care should be taken to ensure that mobile scaffolds are installed on flat surfaces.

- Mobile scaffolds are highly practical for short jobs at relatively low heights.
- Acceptance is carried out after erection has been completed.
- They are moved as the work being carried out progresses. No fresh acceptance is required after each move, but the workstation shall be verified (working distance, brakes applied)
- A freestanding scaffold shall be considered safe when the total height is equal to or less than four times the minimum or least base dimension.
- Rules for use
- Do not extend the base to increase the height.
- Brace each frame level as per the manufacturer's instructions.
- Do not raise work surfaces by placing decks on rails or midribs.
- Do not climb on the guardrails or other structural components.
- Observe the manufacturer's guidelines governing the installation of brackets, material hoists etc.
- Stay clear of power lines and observe safety distances. (If any)

Scaffold safety

The following safety tips are as guidelines in avoiding job-site situations that could prove dangerous to scaffold workmen.

- The Scaffold to the Building: Scaffolding should be tied to the structure using heavy wire or tie-in devices. The first vertical tie should be at the maximum height of 4 times the narrowest base dimension. Additional ties are not to exceed 26 feet vertically. Maximum horizontal distance between ties is not to exceed 30feet.
- Don't Overload Scaffolding: Follow the safe load capacities as given by the scaffold manufacturer. There's a limit even to what steel cansupport.A4-to-1-safetyfactor must be figured on scaffolding.
- Use Metal Catwalks, Platforms; where available. If wood plank is used, it must be scaffold grade or better. Inspect thoroughly before every job to make sure it is free from breaks, knots, and cracks or warp age. Decking should be full width.
- All working platform must be constructed with the specific requirement of job.
- If the working platform is not permanent then safety belt must be used.
- There shall be firm foundation for all scaffoldings. All scaffolding shall be made of sound material.

- Scaffolding material shall be inspected and used, only if found in good condition.
- Provide metal base plate is used under all upright or standard scaffoldings. Correct type of couplers shall be used for all connections.
- Plumb and level scaffoldings as erection proceeds, so that braces will fit without forcing.
- Fasten all braces securely.
- Working platforms shall be provided with guards. This should consist of top rail, mid rail, and toe board. The toe board shall be of minimum height 100 mm, while the mid rail and top rail shall be at heights of 600 mm and 1200 mm respectively.
- Do not use ladders or makeshift devices on top of scaffoldings to increase the height.
- Shall be placed at least 75 deg. to the floor.
- Fall arrestor to be used where ever applicable.
- The following safety tips are as guidelines in avoiding job-site situations that could prove dangerous to scaffold workmen.
- Don't Ride Moving Scaffold; and remember scaffold units are limited in height to 4* times
- Their narrowest base dimension (unless base is widened by outriggers or more end frames; or tied into building.) Always keep casters locked. (except tore-spot)
- Don't Climb Braces: Use the steps provided on most steel scaffolds to climb up to or down from work levels. Use scaffold climbing ladders where required.
- Protect Working Levels: Use overhead canopies to protect workers on lower work levels when work is being done overhead. Rope off un safe areas underneath scaffold or provide wire mesh around work area.
- Use Double Guard Rails; and toe board so exposed side sat platform heights of 1.8 meter or more.

Illustration of a Sample Independent Scaffold

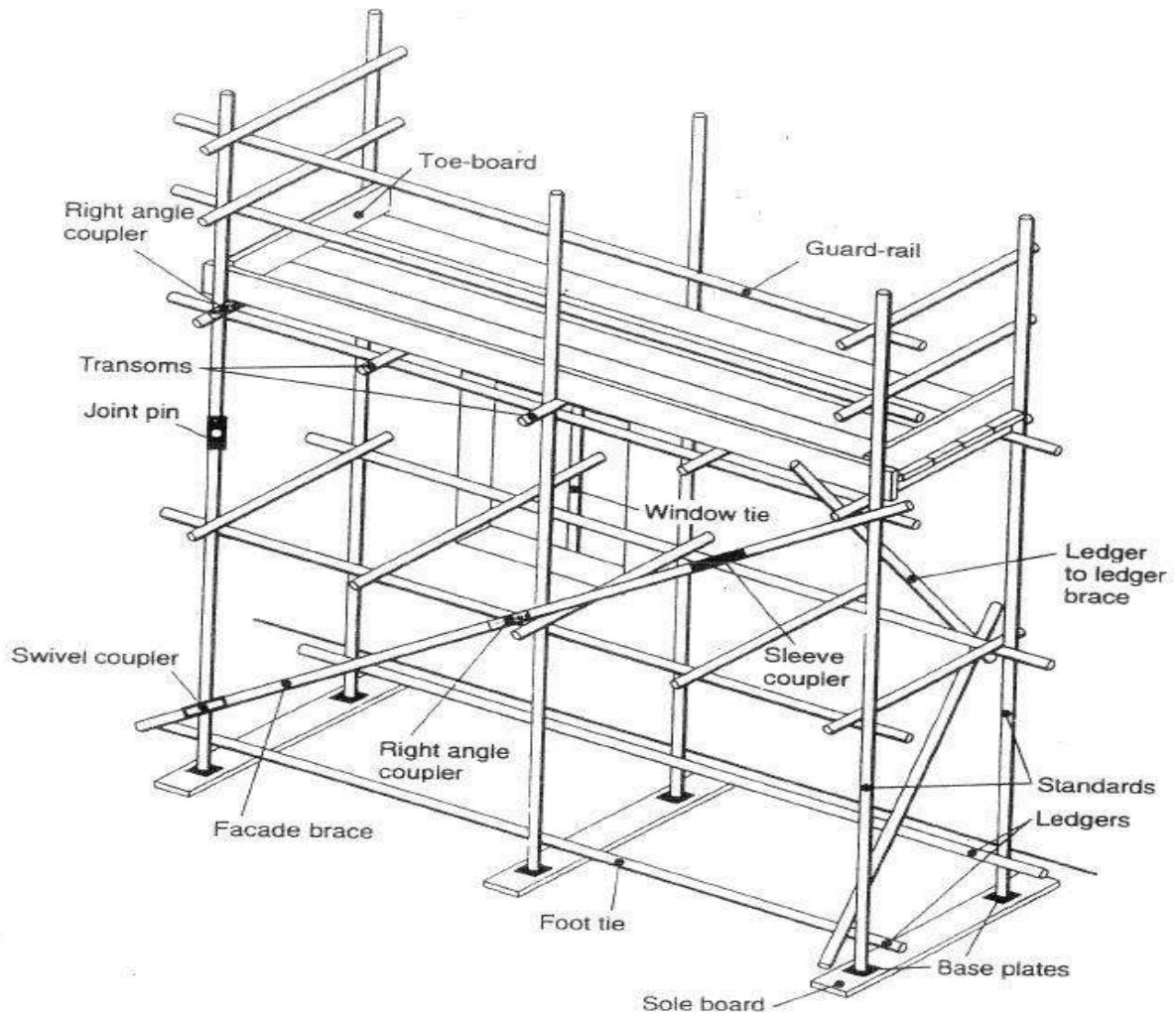

15.6.5 Ladders

- Fall protection is not needed when climbing up or down ladders less than 20 feet/6.1 meters, using 3 points of contacts.
- Portable ladders, steps and trestles should only be used for light duties of short duration. Otherwise, properly constructed means of access should be provided.
- Aluminum ladders can generate sparks when struck against rusty iron, so it must be used in Hazardous Areas with special care.
- Aluminum ladders must not be used in areas where they might be splashed with acids or alkalis ; e.g. Utilities Area

- Ladders with metal reinforced, Damaged or rotten stiles, Missed footing on ladder rungs must not be used.
- Over-reaching and over-balancing is not allowed.
- Every time before use, the user will carry out inspection of ladder.
- If the work to be done necessitates the use of both hands, a safety belt must be used.
- Tools and materials must not be hand carried by persons ascending or descending ladders. Where applicable light tools should be carried in pockets, tool belts or shoulder bags, provided they do not impair movement and are held securely.
- Rungs, stiles, or treads to be checked for bending, twisting or signs of abuse or undue wear.
- Feet to be fitted with various types of bases and in good order. Synthetic non-slip, wooden or metal.
- Non-slip stair treads mats of stepladders, should be fitted and in good condition.
- In case of moving ladders fitted with wheels, Hinges and locking devices to be secure and in good working order.
- All portable ladders must be in good condition as per the site norms.
- Ladder shall extend 3' to 4'above the point of Landing and topmost 3 rungs shall not be used.
- Ladder is checked visually for defects before every use.
- Ladders shall not be used in a horizontal position as runways or scaffoldings.
- Ladders shall not be placed in front of a door that opens toward the ladder unless the door is locked, blocked or guarded.

15.6.6 User Ladder Safety Checklist

The following check list specifies the main points to remember when using ladders:

- Do not erect:
 - On sloping ground
 - On top of movable objects
 - In high wind
 - In front of a door which may be opened
 - Against a slippery or unstable surface

- At a shallow angle, or use horizontally as a plank or bridge
- Leaning to outside

15.6.7 Donor

- Drop things from ladder.
- Straddle from the ladder to a nearby foothold..
- Allow more than one person up a ladder at time.
- Use a ladder which is too short.
- Use a makeshift or 'home-made 'ladder.
- Over-reach (generally always keep hips within the stiles).
- Slide down ladder.
- No ladder should be used if it has: A missing, loose or defective rung or tread.
- A defective stile side member.
- A defective rope or associated fitting (rope operated extension ladders).
- Any sign of warping.
- Missing fastenings or rivets, guide or latching hooks.
- Always Return ladders to store as soon as they are finished with.
- Inspect a ladder immediately after any fall or overload.

15.6.8 Activities Allowed on Ladder

- A ladder is considered to be suitable for access of personnel to an elevated area only. No significant works may be carried out from a ladder. In particular, activities such as those below may not be carried out on ladder:
- Carrying tools (other than those which might clip onto a tool belt) up to an elevated level.
- Activities involving heavy manual labour.
- Activities requiring reaching or stretching such that the body is no longer centered over the ladder.
- For these types of jobs, a work platform such as a scaffold is required. The safe working position from a ladder is to have both thighs and hips within the styles.

15.6.9 Color code and inspection

- Color code of the year shall be painted on one style only and equal to one rung spacing.

15.2. Roof work

- All roof-work operations should be pre-planned and properly supervised.
- Roof work should only be undertaken by workers who are physically and psychologically fit and have the necessary knowledge and experience for such work.
- Work on roofs shouldn't be carried on in weather condition that threaten the safety of workers.
- Crawling boards, walkways and roof ladders should be securely fastened to a firm structure.
- Roofing brackets should fit the slope of the roof and be securely supported. Where it is necessary for a person to kneel or crouch near the edge of the roof, necessary precautions should be taken.
- On a large roof where work have to be carried out at or near the edge, a simple barrier consisting of crossed scaffold tubes supporting a tubing guardrail may be provided.
- All covers for openings in roofs should be of substantial construction and be secured imposition.
- Roofs with a pitch of more than 10 should be treated as sloping.
- When work is being carried out on sloping roofs, sufficient and suitable crawling boards or roof ladders should be provided and firmly secured imposition.
- During extensive work on the roof, strong barriers or guardrails and toe-boards should be provided to stop a person from falling off thereof.
- Where workers are required to work on or near roofs or other places covered with fragile material, through which they are liable to fall, they should be provided with suitable roof ladders or crawling boards strong enough and
- When spanning across the supports for the roof covering to support those workers.
- A minimum of two boards should be provided so that it is not necessary for a person to stand on a fragile roof to move a board or a ladder, or for any other reason.

15.3. Electrical Safety

- Only authorized electrical engineer / electricians are permitted to do the electrical work.

- Do not use extension cords or electric hand tools with exposed wires.
- To switch-off electrical supply in case of an emergency must be enabled at all times.
- All temporary electrical installations carried out on the site must be in accordance with the local regulations and specifications.
- The installations must be inspected regularly by a competent person (e.g. electrical engineer/supervisor) to ensure that they are in safe condition and working faultlessly.
- Each electrical power tools and electrical equipment must be under protection of earth leakage/residual current protective device(ELCB/RCCB).
- Portable power tools used on site must have protective insulation ("double insulation").
- All electrical machines, tools and appliances must be inspected by a competent person (e.g. electrician) to ensure that all equipment's are in safe condition and working faultlessly. To confirm that the inspection was conducted the equipment must be labeled or marked clearly and registered. The documentation must be submitted to TE for records.
- Assume that all circuits are live until they have been thoroughly checked and proven dead. Never work on a live circuit.
- When using electrical equipment in an environment with electrical conductivity (e.g. in confined spaces like case pipes, containers, towers) the voltage used may at maximum be 24 Volt AC. (fed from a safety low voltage transformer)
- Never use a fuse heavier than the capacity of the circuit. Also never attempt to bridge abuse.
- Never tamper with any electrical wiring or apparatus.
- Do the cable laying as per standard specifications and requirement; do not lay down power cables adjacent to secondary cables of welding machine.
- Assess overhead power line hazard and keep safe distance from it.
- All electrical equipment's, motors, transformers, welding machines, etc. to be provided with earth connections.

15.4. Power & Hand Tool Operation

- All portable tools are to be connected through control bus with ELCB.
- All contractors should ensure proper Earthing of all electrical equipment's used by

them. Suitable earthing pits must be made if required.

- Examine electric cable for defects before use.
- Do not ever insert free ends of wires into sockets and hold them in place with matchsticks / other means. Always use industrial three pin plugs.
- Check the RPM rating of grinding wheels. The RPM rating must be greater than or same to that of the driver. Wheel guard should be used in proper position before grinding. Also proper PPEs must be ensured (goggles & hand gloves).
- Do not tie electric cords to metal rods or nails.
- No cable should run under the ground. It must run overhead at a 2 m height to avoid pinch point and creating trip hazard
- All tools and Tackles must be examined daily before commencing work and record to be maintained.
- Defective tools are to return to store.
- All electrical tools must be inspected at regular intervals by an authorized electrical person and record to be maintained.
- The weight, size & type of tool should be selected to suit the job carried out.
- The handles of tools should be intact and properly tightened. Split handles should be replaced. To avoid slippage, grease and oil should be wiped off.
- Insulated and non-conducting tools shall be tested for electrical resistance.
- Wrenches should not be pushed but pulled. Chisels struck by others should be held by tongs and not by hands.
- Chipping should always be done away from self.
- Hand tools should not be allowed to lie down on benches, scaffoldings etc. from where they can fall. They should be properly stored.

15.5. Welding

The metal frames and cases of mains-powered welding rectifiers, transformers and voltage regulators and of engine driven welding machines must be positively earthed locally throughout the work.

- Welding leads and return leads must be protected against physical damage.
- Insulated electrode holders and cable lugs / protectors must be used.
- The return lead must be attached to the work place as close as reasonably practicable to the welding point.
- If mains power is used, the work piece must be positively earthed using a well-

protected earth wire connected at both ends by bolted lugs or secure screw clamps.

- Bolted joints in pipelines and structures must not be relied upon to provide adequate electrical continuity for welding currents.
- Electric arc welding should not be carried out on equipment suspended from a crane because of the risk of damage to lifting wires from uncontrolled stray currents.
- Welders must not wear metal rings, bracelets or necklaces during the work as induced currents from the welding equipment might heat these.
- Dry, non-conductive gloves should be worn.
- The welder must always disconnect the electrode holder from the supply before attempting to replace an electrode.
- The welder should not lean against an earthed conductor whilst manipulating live electrodes.
- Welders working with electrodes fed from different phases of a three-phase supply should not work in close proximity to one another.
- Ensure that welding machine is in order and approved by site engineer.
- Ensure that welding cables are in order.
- Remove all combustible material from welding area to avoid fire.
- Place a fire extinguisher nearby welding premises.
- Ensure welding holder, cable and its lugs in good condition and use only industrial power socket and plugs (3 Pin) to avoid electricity risk.
- Make sure that welding machine is provided with ON/OFF switch and is earthed/grounding.
- Do not over load electrical appliances and cable, shocked pined.

15.6. Gas Cutting

- Gas cylinders must be secured in the vertical position to prevent them being knocked or pulled over.
 - Long lengths of hose should be avoided, but;-
 - Cylinders must be kept far enough away from the welding or cutting operation to prevent contact with sparks, flames and metals platter.
-

- Cylinders must be placed where they are unlikely to be damaged by stray electric currents or falling objects.
- Cylinders must not be taken into confined spaces.
- The torch must always be lit from a lighter provided for the purpose. There should be no attempt to light it from hot metal.
- Check the cylinder and its valve or leakage and move out any leaking cylinder immediately.
- Ensure that flash back arresters are installed with torch and NRV (Non return valve) on the gas cylinders side.
- Ensure cylinder is far away from fall of sparks and hot metal.
- Check the regulator and torches that they are inspected prior to every use.
- Check for leaks around regulators, hoses/fittings & nozzle with soap solution.
- Check the entire hose length if it is cracked or worn out cut that length of hose or replace the hose.
- Check that flash back arrester used for the purpose is of approved make/specification only.
- Place a fire extinguisher nearby welding premises.

15.6.1. Gas Cylinders

The handling of gas cylinders must comply with local legislation and TE's regulations as per particulars given below:

- Gas cylinders must be stored protected from excessive heat, fire, dangerous corrosion, mechanical damage or access by unauthorized.
- Gas cylinders must not be stored together with flammable materials.
- Gas cylinders must be secured to prevent them from falling over.
- Gas cylinders must be capped and operated upright.
- Use cylinder trolley / cage for the transportation of gas cylinders at site.
- Never use oil or grease on the regulator of a cylinder valve.
- Store gas cylinders in ventilated area.
- Don't keep LPG cylinder in confine/below ground area.
- Gas stores must not be set up in critical areas such as stairways, corridors,

emergency routes, garages or passages for person's or vehicles.

- Never transport by rolling them on the ground or use them as rollers or supports.
- Never attempt to repair cylinder.
- Leaking regulators, cylinder valves, hose pipes or other equipment should be taken out of service.

15.7. Grinding Operation

- Grinding wheels should be stored in dry place.
- After expiry date, grinding wheel must be condemned, broken in to pieces.
- Power supply cable of adequate current carrying capacity shall be used and it should be in good workable condition without abrasions, cuts or puncture in outer insulation.
- Socket pin provided at supply end and On/off switch in working condition.
- Proper earthing of the body in case of metallic body.
- Wheel guard properly fitted imposition.
- Machine body without any damage like cricket.
- Moving part (wheel) must be properly fixed to the machine with the help of spanner.
- Grinding wheel must be of suitable size as per the speed of grinding machine.
- Grinding wheel without manufacturer's stickers having size, speed and expiry date must be condemned.
- Don't use portable grinding machine as bench grinder.
- Don't fit over size wheel than recommended size by machine/wheel manufacturer.
- Don't grind small, unstable object without fixing it in the vice.
- Don't over press the grinding wheel against the job for fast removal of metal.
- Put OFF the main switch, while machine is not in use (tea breakneck.).
- Don't chip off grinding/cutting wheel for achieving fast cutting rate.

PPEs:

- Use of helmet, face shield or safety goggles (where face shield is not possible.) and hand gloves.

15.8. Use of Power Tools and Cables

- All electrical equipment and tools used by the contractors and their employees shall be properly checked by contractor's supervisor before use.
- All power tools must have proper guard at all-time.
- Leads /cables must be placed so that they do not create a tripping hazard.

15.9. Pressure / Leak Testing

Hydrostatic and Pneumatic Test

Access to the test area shall be limited to essential personnel only. before the test commences compliance is required with the following points:

- Persons supervising pressure or leak tests must have sufficient knowledge and experience of testing to fully understand the hazards of the activity and the precaution, which must be taken.
- Effective communication, including formal procedures, must be established between sites whenever the test envelope extends beyond one site, for example, pipelines.
- The area shall be cordoned off (using tape, shields or barriers, etc.) at an adequate distance from the equipment to be tested, as specified on the Permit to Work
- Warning signs shall be posted at access ways, at other strategic positions, and on the equipment to be tested (including the doors of test workshops or other designated areas.
- Pressuring equipment shall be provided with suitably calibrated pressure control/regulator devices
- Pressuring equipment shall not be left unattended at any time during the test.
- Pressuring equipment shall be isolated from the equipment under test and where practicable disconnected, when the test pressure has been reached.
- Care must be taken to ensure that materials of construction have the required ductility at the test temperature to prevent brittle fracture.
- A safety valve should be fitted to the equipment/system being tested, set to relieve at a pressure that will prevent over pressurization.
- Sufficient venting / draining points shall be provided in order to prevent trapping of pressurizing medium behind non-return valves, check valves, between isolation

valves, or within dead legs of the pressure envelope.

- The equipment/plant to be pressure tested must be subjected to thorough examination prior to testing. It may be necessary to 100% inspect all welds using visual, radio graphic or other NDT techniques.
- The gas supply must be isolated when test pressure has been achieved.
- The pressure envelope must contain sufficient vents, to a safe location.
- De-pressurization after pneumatic testing must be gradual.

15.10. Barricades and Warning Signs

- Area where work is being carried out above man height or below 1' ground depth must be barricaded. Linked barrier with link chains must be provided by the contractor for cordoning the area at ground level, during GI work.
- Follow the instruction of all types of warning signs like "NO SMOKING" "NOENTRY" "DANGER" "Work at height", "Inconvenience to member of public regretted/work in progress",
- Name of the Contractor and contact details"

15.11. Basic Safety Rules For The Construction Site

- The construction site shall be considered a restricted area and unauthorized entry into the site is strictly prohibited. Anyone found trespassing should be asked to leave the site immediately.
- All persons of CLIENT/Consultant/Contractor shall be responsible for their own safety in plant or work sites.
- Nobody authorized to touch any valve, switch, or interfere with plant/site activities.
- Children below 18 years are not allowed inside plant / worksite.
- Never walk on the pipes, equipment, structure etc.
- Always use stairs, handrails & walkover platforms.
- Never carry sharp or pointed tools in pockets.
- Alcoholic beverages will not be consumed, brought into, or manufactured on the work sites or inside the plant.
- Drugs/intoxicant substances will not be used, brought into, or manufacture don't he site or plant.

- Cigarette, beedi smoking is not allowed except in the designated smoking booths.
- Firearms, explosives, knives or other types of weapons will not be allowed on the site.
- Gambling or any other form of betting games is prohibited.
- Discrimination on the basis of race, sex or national origin is prohibited.
- Horseplay, Fight, Practical jokes, Aggressive or abnormal behavior is prohibited.
- Individuals under the influence of alcohol or drugs will not be permitted entry to the site.
- Safety helmet, safety shoes, ear plug or ear muff, hand gloves, safety goggles, safety harness & clothing for body protection are mandatory in the plant or work site.
- Use other personal protective equipment as displayed in plan/site.
- It is strictly not allowed to use non-intrinsically safe equipment or instruments in the operational area of site.
- All vehicles for use on the site shall conform to the requirements of the Vehicle Entry Permit. Maximum Speed limit inside complex is 10km/Hr.
- In case of Emergency dial appropriate agency like Fire, Hospital, Security etc as displayed.

Violation of the Rules and Regulations might result in removing the person(s) concerned from the premises and denying the person(s) concerned from any future access to the site. The site in-charge will judge whether permanent removal of the individual from the premises is justified depending on the seriousness of the violation(s). All Indian laws shall be complied with at all the time.

15.12. Site Emergency Preparedness and Response

The CONTRACTOR shall establish, what are the arrangements in the event of an emergency.

The CONTRACTOR shall ensure that their Personnel are familiar with the essential emergency equipment, the use of which shall be demonstrated and practiced in drills.

The CONTRACTOR shall check the emergency procedures and the location and condition of the emergency equipment.

The CONTRACTOR personnel will be instructed of the actions to take in the event of serious personal injury, gas or toxic release, fire, explosion, heavy rains, wind storms, chemical spillage, land slide, scaffolding or structure collapse, critical damage to operating equipment, etc. and other emergency situations during the induction training and other

ongoing training sessions.

These situations may demand adequate rescue and relief measure to handle such events quickly and effectively.

In an emergency, or on hearing the alarm, every supervisor shall ensure the following;

- All work is stopped at once.
- All equipment vehicles and tools are shut down (all sources of ignition).
- All men are evacuated to a pre-determined Muster point.
- A roll call is taken and every man is accounted for.
- No one is permitted to return to work until notification has been received from the CONTRACTOR representative that it is safe to do so.

15.12.1. Emergency Preparedness

The basic and essential features of any emergency Preparedness are to analyse and plan for the potential risk. This includes;

- Establishing and maintaining effective communications.
- Liaison with local emergency services and authorities.
- Action Procedure (evacuation routes and assembly points).
- Appointment of key personnel and specifying their duties and responsibility.
- Emergency Response Drills

15.12.2. Emergency Response Drills

Effectiveness and comprehensiveness of Emergency Response Plan must be tested on a regular basis. Drills which reflect the conditions induced from the more likely emergency occurrences must be conducted. CONTRACTOR should conduct such drills on a periodic basis. All emergency drills, exercises and responses to actual incidents shall be fully documented and followed by a complete review and when necessary, procedure revision process.

Initiate any required procedural changes, and initiate the dissemination of any lessons learned through the Site HSE communication system.

15.13. Road Safety Norms

- For roadside working site to be barricaded.
- Only eligible driver can drive required vehicle inside site
- Speed limit norms of site must be followed
- No riding or travelling on the back of open end vehicle, fork lift or trailers should be done.

15.14. Environment

The CONTRACTOR shall pay due regard to the environment by preserving air, water, soil, animal and plant life from adverse effects of the CONTRACTOR's activities and minimizing any nuisance which may arise from such operations.

All waste generated by the CONTRACTOR shall be contained and disposed of in accordance with the legal requirement on waste management.

15.15. Labor Welfare & Legal Requirement

- All mandatory provisions with regard to safety as prescribed under contract Labor (Abolition & Regulation) Act 1970 and Rules made there under are applicable.
- Workmen compensation insurance and registration under ESI should be maintained.
- Time to time, all rules and regulations suggested by safety committee of site must be followed and implemented

ANNEXURES

ANNEXURE – A

RELEVANT IS-CODES FOR PERSONNEL PROTECTION

IS : 2925 – 1984	:Industrial Safety Helmets
IS : 4770 – 1968	:Rubber gloves for electrical purposes
IS : 6994 – 1973	:Industrial Safety Gloves (Leather & Cotton)
(Part – I)	
IS : 1989–1986	:Leather safety boots and
shoes (Part – I & III)	
IS : 3738 – 1975	:Rubber knee boots
IS : 6519 – 1971	:Code of practice for selection, care and repair of Safety footwear
IS : 11226 – 1985	:Leather Safety footwear having direct molding sole
IS : 5983 – 1978	:Eye protectors
IS : 9167 – 1979	:Ear protectors.
IS : 3521 – 1983	:Industrial Safety belts and harness



**QUALITY ASSURANCE PLAN
FOR
MDPE PIPE**

S.No.	Activity	Quantum of Check	Acceptance Criteria (IS-14885:2001 or and SS-71127/D/31/0398)	Format of Record	Vendor	TPIA	Remarks
1	Raw Material Inspection						
	Test result of PE compound	Per Lot of Batch of Compound	PE - 100 Cl. No. 5 of IS & SS	MTC of manufacturer	R	R	Witness may be done by CA to insure use of compound material
2	Type approval test for long term hydrostatic strength & Others	-	@ 80 ° C for 1000 hours @ 20 ° C for more than 100 hours As per Table 7 of IS	TPIA approved certificate	R	R	
3	In-Progress Inspection						
3.1	Raw Material Identification at the time of pouring the bags in Hopper.	Each Bag	PE - 100 Cl. No. 5 of IS & SS	Consumption Report	P	H	TPI to verify MTC of each batch for consumption
4	Final Inspection						
4.1	Visual Appearance						
	a) Smoothness & Cleanliness	One out of 10 Pipes	Smooth & clean or as specified in CL no. 7 of IS 14885	--	P	W	
	b) Surface Defects		Free from grooves, scoring etc. or as specified in CL no. 7 of IS 14885	--	P	W	
	c) Cuttings		Cleanly cut ends & square to axis or as specified in CL no. 7 of IS 14885	--	P	W	
4.2	Dimension						
	a) Outside diameter	One out of 10 Pipes	Cl no. 6 /Table 4 of IS	Inspection Report	P	W	
	b) Wall Thickness		Cl no. 6 /Table 4 of IS	Inspection Report	P	W	
	c) Ovality		Cl no. 6 /Table 3 of IS	Inspection Report	P	W	
	d) Length		Cl. No. 7.2 & 8 of SS	Inspection Report	P	W	
4.3	Hydraulic Characteristics						
	80°C for 165 hrs	Table 9	Cl 8.1, Annexure A & B & Table 7 of IS	Hydrotest Report	P	W	Preferably random witness by CA
4.4	Heat reversion test	Table 11	CL 8.2, Annexure C of IS / Not more than 3%	Inspection Report	P	W	
4.5	Density (matl. From pipe)		@ 23 ° C ≥ 928.4 kg/m ³ & '@ 27 ° C ≥ 930 kg/m ³	Inspection Report	P	W	
4.6	Melt Flow Rate - Pipe		Cl 5.3 of SS	Inspection Report	P	W	



**QUALITY ASSURANCE PLAN
FOR
MDPE PIPE**

S.No.	Activity	Quantum of Check	Acceptance Criteria (IS-14885:2001 or and SS-71127/D/31/0398)	Format of Record	Vendor	TPIA	Remarks
4.7	Thermal Stability to Oxidation		CI 8.5, Annexure D of IS / OIT \geq 20 minutes	Inspection Report	P	W	Preferably random witness by CA
4.8	Volatile Matter Content Test	-	CI 8.6, Annexure H of IS / \leq 350 mg/kg	Inspection Report	P	W	
4.9	Tensile Test & Elongation at break	Table 11	CI 8.7& Annexure J of IS / Tensile Yield Strength = 15 Mpa (min.), Elongation = 350% (Min.)	Inspection Report	P	W	
4.10	Resistance to weathering	-	CI 8.8 & Annexure F of IS	Inspection Report	P	R	
4.11	Squeeze Off Test	-	CI 8.9 & Annexure G of IS	Inspection Report	P	W	
5	Marking Information						
	1. Legibility	Table 10	Visual / Should be legible	Inspection Report	P	R	
	2. Depth	Table 10	As per CI 10 of SS, Depth < 0.15 mm	Inspection Report	P	RW	
	3. Marking Strip	Table 10	CI 10 of IS, Single Strip for Pipes with Nominal Size \leq 32mm & two strips on opposite side of pipe for other pipes.	Inspection Report	P	RW	
	4. Colour or Marking	Table 10	As per CI 10 of SS, Black colour	Inspection Report	P	RW	
	5. Height of Character	Table 10	As per CI 10 of SS, Min.3 mm for < 90mm pipe sizes & Min. 5 mm for > 90mm pipe sizes.	Inspection Report	P	RW	
	6. Legends	Table 10	As per CI 10 of SS, At interval of 1 mtrs. And should contain information as specified in SS	Inspection Report	P	RW	
6	Final Documentation	-	P.O. / SS	Compliance Certificate	p	H	

LEGENDS: R - Review, W - Witness, RW - Random Witness, H - Hold, P - Perform, TPIA - Third Party Inspection Agency, CA - Control Authority (Owner / owner's representative), P.O. - Purchase order

Notes: -

1	The Above Testing and acceptance criteria are minimum requirements, however, manufacturer shall ensure that the product shall also comply to the additional requirements as per Standard Specification (SS)
2	The supplier shall submit their own detailed QAP prepared on the basis of above / Technical specification for approval of Owner/Owner's representative.
3	Owner/Owner representative shall review/approve all the documents related to QAP/Quality manuals/Drawings etc.submitted by supplier.
4	Contractor shall in coordination with Supplier/Sub vendor shall issue detailed Production and Inspection schedule indicating the dates and the locations to facilitate Owner/Owner's representative and TPIA to organise Inspection.
5	Special manufacturing procedures have to be specially approved or only previously approved procedures have to be used, in case of conflict between specifications more stringent condition shall be applicable.
6	Owner / Owner's representative including TPIA will have the right to inspect any activity of manufacturing at any time.
7	All reference Codes/ Standards, Documents, P.O. Copies shall be arranged by vendor / supplier for reference of TPIA/HOGPL at the time of Inspection



**QUALITY ASSURANCE PLAN
FOR
MDPE PIPE**

S.No.	Activity	Quantum of Check	Acceptance Criteria (IS-14885:2001 or and SS-71127/D/31/0398)	Format of Record	Vendor	TPIA	Remarks
9	At the time of delivery of material in stores, vendor will submit copy of all related document of inspection along with release note & MTC.						
Prepared by			Reviewed / Checked by		Approved by		
(Name / Signature / Date / Stamp)			(Name / Signature / Date / Stamp)		(Name / Signature / Date / Stamp)		



QUALITY ASSURANCE PLAN

ANNEXURE-I QUALITY ASSUARANCE PLAN

Item: Electrofusion Fittings PE 100- Coupler, Reducer, Elbow 90°, Elbow 45°, End Caps, Saddle, Equal tee & Transition Fittings

Sr. No.	Test Description	Type Of Check	Quantum Of Check	Ref. Document	Acceptance Norms	Documentation	Inspection		Remarks
							Mfg.	C/TPIA	
1	Dimension Check	Geometrical Characteristics	01 No. from Lot	Mfg. Drawing	EN 1555-3 / Mfg. Drawing	Mfg. test certificate	P	W	
2	Melt mass flow rate	Physical Characteristics	01 No. from Lot	ISO 1133	MFR 190°/5kg. 0.20 – 1.20 gm./10 min.	Mfg. test certificate	P	R	
3	Density	Physical Characteristics	01 No. from Lot	ISO 1183	0.926 to 0.94 g/cm ³	Mfg. test certificate	P	R	
4	OIT (Thermal Stability)	Physical Characteristics	01 No. from Lot	ISO 11357-6/ EN 728	Oxidation Induction Time ≥ 20 min/200° C	Mfg. test certificate	P	R	
5	Appearance, Color	General Characteristics	01 No. from Lot	EN 1555- 3	Mfg. Spec.	Mfg. test certificate	P	W	
6	Hydrostatic Strength (PE100)	Mechanical Characteristics		EN 1555- 3 & ISO 1167-1-4	Case I- 165h/80°C/(5.5M Pa)	Hydrotest Report	P	W	
					Case II- 100h/20°C/(12 MPa)				
					Case II- 100h/20°C/(10 MPa)				



QUALITY ASSURANCE PLAN

8	Peel Decohension Test for Electrofusion socket fitting	Mechanical Characteristics		ISO 13954	EN 1555-3	Inspection Report	P	W	
9	Crush Decohension Test for Electrofusion socket fitting	Mechanical Characteristics		ISO 13955	EN 1555-3	Inspection Report	P	W	
10	Decohension Test (tear test) for Electrofusion saddle fittings	Mechanical Characteristics		ISO 13956	EN 1555-3	Inspection Report	P	W	
11	Impact Resistance for Electrofusion saddle fittings	Mechanical Characteristics		EN 1716	EN 1555-3	Inspection Report	P	W	
12	Pressure Drop.	Mechanical Characteristics	01 No. from Lot	ISO 17778	EN 1555-3	Inspection Report	P	R	
13	Electrical Resistance	Electrical Characteristics	01 No. from Lot	EN 1555-3	EN 1555-3	Inspection Report	P	R	

Note:

- The above testing and acceptance criteria are minimum requirements; however, manufacturer shall ensure that the product shall also comply to the additional requirements as per Standard specifications (SS).



QUALITY ASSURANCE PLAN

2. The supplier shall submit their own detailed QAP prepared on the basis of above / technical specification for approval of Owner/Owner's representative.
3. Owner/Owner representative shall review/approve all the documents related to QAP/Quality manuals/Drawings etc. submitted by supplier.
4. Contractor shall in coordination with Supplier/Sub vendor shall issue detailed Production and Inspection schedule indicating the dates and the locations to facilitate Owner/Owner's representative and TPIA to organize Inspection.
5. Special manufacturing procedures have to be specially approved or only previously approved procedures have to be used, in case of conflict between specifications more stringent condition shall be applicable.
6. Owner / Owner's representative including TPIA will have the right to inspect any activity of manufacturing at any time.
7. All reference Codes/ Standards, Documents, P.O. Copies shall be arranged by vendor / supplier for reference of TPIA/HOGPL at the time of Inspection
8. At the time of delivery of material in stores, vendor will submit copy of all related document of inspection along with release note & MTC.

LEGENDS:

M – Monitor

R – Review

H – Hold

TPIA – Third Party Inspection Agency

P – Perform

W – Witness

C – Customer

V – Verification of Mfg. Test Certificate

Prepared by	Reviewed / Checked by	Approved by
(Name / Signature / Date / Stamp)	(Name / Signature / Date / Stamp)	(Name / Signature / Date / Stamp)



QUALITY ASSURANCE PLAN ISOLATION VALVE

QAP NO : 14588/03-CD-MC-QAP-001

Rev. 0

Date :

SR. NO.	INSPECTION AND TESTING	QUANTUM OF CHECK / TEST	PROCEDURE	ACCEPTANCE CRITERIA AND CERTIFICATE	FORMAT OF RECORD	INSPECTION BY		REMARKS
						Manufacturer	TPIA	
1.0	Raw Material							
1.1	Metallic Parts (Chemical / Physical Requirement)	One in each heat	As per ASTM B 283 (ALLOY UNS C37700) / EN 331	As per ASTM B 283 (ALLOY UNS C37700) / EN 331	MATERIAL TEST CERTIFICATE	P	R	
1.2	Seat & Stem Seal	One in each heat	As per EN 331 / Manufacturer's Standard	As per EN 331 / Manufacturer's Standard	MATERIAL TEST CERTIFICATE	P	R	
2.0	Final Product :							
2.1	Gas Tightness Test	100%	As per EN 331	As per EN 331	TEST REPORT	P	W = Ten nos. per size per Lot	
2.2	Bending Test	One no. per Heat per Size	As per EN 331	As per EN 331	TEST REPORT	P	W = One no. per size per Lot	
2.3	Turning Torque Test	One no. per Heat per Size	As per EN 331	As per EN 331	TEST REPORT	P	W = One no. per size per Lot	
2.4	Temperature Resistance Test	One no. per Heat per Size	As per EN 331	As per EN 331	TEST REPORT	P	W = One no. per size per Lot	
2.5	Flow Capacity Test	One no. per Heat per Size	As per EN 331	As per EN 331	TEST REPORT	P	W = One no. per size per Lot	
3.0	Visual Inspection (Free from defects)	100%	As per EN 331	As per EN 331	INSPECTION REPORT	P	W = Ten nos. per size per Lot	
4.0	Dimension Tolerances (Min. length of engagement , OD , wall thk.)	100%	As per Approved Drawing	As per Approved Drawing	INSPECTION REPORT	P	W = Ten nos. per size per Lot	
5.0	Marking	100%	As per EN 331	As per EN 331	INSPECTION REPORT	P	W = Ten nos. per size per Lot	
6.0	Final Documentation		As per P.O. / SS	As per P.O. / SS	EN 10204 3.2 CERTIFICATE	P	H	

LEGEND: R - Review, W - Witness, H - Hold, P - Perform, TPIA - Third Party Inspection Agency, CA - Control Authority (Owner / Owner's representative)

Notes: -

- 1 The Above Testing and acceptance criteria are minimum requirements, however, manufacturer shall ensure that the product shall also comply to the additional requirements as per Standard Specification (SS)
- 2 The supplier shall submit their own detailed QAP prepared on the basis of above / Standard specification for approval of Owner/Owner's representative.
- 3 Owner/Owner representative shall review/approve all the documents related to QAP/Quality manuals/Drawings etc. submitted by supplier.
- 4 Contractor shall in coordination with Supplier/Sub vendor shall issue detailed Production and Inspection schedule indicating the dates and the locations to facilitate Owner/Owner's representative and TPIA to organize Inspection.
- 5 Special manufacturing procedures have to be specially approved or only previously approved procedures have to be used, in case of conflict between specifications more stringent condition shall be applicable.
- 6 Owner / Owner's representative including TPIA will have the right to inspect any activity of manufacturing at any time
- 7 All reference Codes/ Standards, Documents, P.O. Copies shall be arranged by vendor / supplier for reference of TPIA/HOGPL at the time of Inspection
- 8 At the time of delivery of material in stores, vendor will submit copy of all related document of inspection along with release note & MTC.
- 9 All Tests shall be carried out as per EN-331 (Latest Edition).



QUALITY ASSURANCE PLAN

ANNEXURE-II QUALITY ASSURANCE PLAN Item: MDPE Ball Valve – PE 100 (Without Stem)

Sr. No	Test Description	Type Of Check	Quantum of Check	Ref. Document	Acceptance Norms	Documentation	Inspection		Remarks						
							Mfg.	C/TPIA							
1	Dimension Check	Geometrical Characteristics	01 No. from Lot	Mfg. Drawing	EN 1555-3 / EN 1555-4 / Mfg. Drawing	Mfg. test certificate	P	W							
2	Melt mass flow rate	Physical Characteristics	01 No. from Lot	ISO 1133	MFR 190°/5kg. 0.20 – 1.20 gm./10 min.	Mfg. test certificate	P	R							
3	Density	Physical Characteristics	01 No. from Lot	ISO 1183	0.926 to 0.94 g/cm ³	Mfg. test certificate	P	R							
4	OIT (Thermal Stability)	Physical Characteristics	01 No. from Lot	ISO 11357-6/ EN 728	Oxidation Induction Time ≥ 20 min/200° C	Mfg. test certificate	P	R							
5	Volatile Content	Physical Characteristics	01 No. from Lot	EN 12099	≤ 350 mg/kg	Mfg. test certificate	P	R							
6	Carbon Black Content	Physical Characteristics	01 No. from Lot	ISO 6964	2.50 ± 0.5%	Mfg. test certificate	P	R							
7	Appearance, Color	General Characteristics	01 No. from Lot	EN 1555- 4	Mfg. Spec.	Mfg. test certificate	P	W							
8	Hydrostatic Strength	Mechanical Characteristics	01 No. from Lot	EN 1555- 4 & ISO 1167-1/4	Case I- 165h/80°C/(5.5MPa) Case II- 100h/20°C/(12 MPa)	Hydrotest Report	P	W							
9	Operating Torque	Mechanical Characteristics	01 No. from Lot	EN 1555- 4	<table border="1" style="width: 100%; border-collapse: collapse;"> <tr> <td style="width: 50%;">$\varnothing \leq 63$</td> <td style="width: 50%;">35Nm</td> </tr> <tr> <td>$\varnothing 63- \varnothing 125$</td> <td>≤70Nm</td> </tr> <tr> <td>$\varnothing 125- \varnothing 315$</td> <td>≤150Nm</td> </tr> </table>	$\varnothing \leq 63$	35Nm	$\varnothing 63- \varnothing 125$	≤70Nm	$\varnothing 125- \varnothing 315$	≤150Nm	Mfg. test certificate	P	R	
$\varnothing \leq 63$	35Nm														
$\varnothing 63- \varnothing 125$	≤70Nm														
$\varnothing 125- \varnothing 315$	≤150Nm														
10	Leak Tightness	Mechanical Characteristics	01 No. from Lot	EN 1555- 4	Table-1, EN 1555-4	Mfg. test certificate	P	R							
11	Pressure Drop.	Mechanical Characteristics		ISO 17778	EN 1555-3	Approval Certificate	P	R							

Note:

- The above testing and acceptance criteria are minimum requirements; however, manufacturer shall ensure that the product shall also



QUALITY ASSURANCE PLAN

comply to the additional requirements as per Standard Specification (SS).

2. The supplier shall submit their own detailed QAP prepared on the basis of above / technical specification for approval of Owner/Owner's representative.
3. Owner/Owner representative shall review/approve all the documents related to QAP/Quality manuals/Drawings etc. submitted by supplier.
4. Contractor shall in coordination with Supplier/Sub vendor shall issue detailed Production and Inspection schedule indicating the dates and the locations to facilitate Owner/Owner's representative and TPIA to organize Inspection.
5. Special manufacturing procedures have to be specially approved or only previously approved procedures have to be used, in case of conflict between specifications more stringent condition shall be applicable.
6. Owner / Owner's representative including TPIA will have the right to inspect any activity of manufacturing at any time.
7. All reference Codes/ Standards, Documents, P.O. Copies shall be arranged by vendor / supplier for reference of TPIA/HOGPL at the time of Inspection
8. At the time of delivery of material in stores, vendor will submit copy of all related document of inspection along with release note & MTC.

LEGENDS:

M – Monitor
P – Perform

R – Review
W – Witness

H – Hold
C – Customer

TPIA – Third Party Inspection Agency
V – Verification of Mfg. Test Certificate

Prepared by	Reviewed / Checked by	Approved by
(Name / Signature / Date / Stamp)	(Name / Signature / Date / Stamp)	(Name / Signature / Date / Stamp)



**QUALITY ASSURANCE PLAN
APPLIANCE VALVE**

QAP NO : 14588/03-CD-MC-QAP-002

Rev. 0

Date : 21.05.2018

SR. NO.	INSPECTION AND TESTING	QUANTUM OF CHECK / TEST	PROCEDURE	ACCEPTANCE CRITERIA AND CERTIFICATE	FORMAT OF RECORD	INSPECTION BY		REMARKS
						Manufacturer	TPIA	
1.0	Raw Material							
1.1	Metallic Parts (Chemical / Physical Requirement)	One in each heat	As per ASTM B 283 (ALLOY UNS C37700) / EN 331	As per ASTM B 283 (ALLOY UNS C37700) / EN 331	MATERIAL TEST CERTIFICATE	P	R	
1.2	Seat & Stem Seal	One in each heat	As per EN 331 / Manufacturer's Standard	As per EN 331 / Manufacturer's Standard	MATERIAL TEST CERTIFICATE	P	R	
2.0	Final Product							
2.1	Gas Leak Tightness Test	100%	As per EN 331	As per EN 331	TEST REPORT	P	W = Ten nos. per size per Lot	
2.2	Bending & Torque Test	One no. per Heat per Size	As per EN 331	As per EN 331	TEST REPORT	P	W = One no. per size per Lot	
2.3	Operating Torque Test	One no. per Heat per Size	As per EN 331	As per EN 331	TEST REPORT	P	W = One no. per size per Lot	
2.4	Temperature Resistance Test	One no. per Heat per Size	As per EN 331	As per EN 331	TEST REPORT	P	W = One no. per size per Lot	
2.5	Flow Capacity Test	One no. per Heat per Size	As per EN 331	As per EN 331	TEST REPORT	P	W = One no. per size per Lot	
3.0	Visual Inspection (Free from defects)	100%	As per EN 331	As per EN 331	INSPECTION REPORT	P	W = Ten nos. per size per Lot	
4.0	Dimension Tolerances (Min. length of engagement , OD , wall thk.)	100%	As per Approved Drawing	As per Approved Drawing	INSPECTION REPORT	P	W = Ten nos. per size per Lot	
5.0	Marking	100%	As per EN 331	As per EN 331	INSPECTION REPORT	P	W = Ten nos. per size per Lot	
6.0	Final Documentation		As per P.O. / SS	As per P.O. / SS	EN 10204 3.2 CERTIFICATE	P	H	

LEGEND: R - Review, W - Witness, H - Hold, P - Perform, TPIA - Third Party Inspection Agency, CA - Control Authority (Owner / Owner's representative)

Notes: -

- 1 The Above Testing and acceptance criteria are minimum requirements, however, manufacturer shall ensure that the product shall also comply to the additional requirements as per standard Specification (SS)
- 2 The supplier shall submit their own detailed QAP prepared on the basis of above / Technical specification for approval of Owner/Owner's representative.
- 3 Owner/Owner representative shall review/approve all the documents related to QAP/Quality manuals/Drawings etc. submitted by supplier.
- 4 Contractor shall in coordination with Supplier/Sub vendor shall issue detailed Production and Inspection schedule indicating the dates and the locations to facilitate Owner/Owner's representative and TPIA to organize Inspection.
- 5 Special manufacturing procedures have to be specially approved or only previously approved procedures have to be used, in case of conflict between specifications more stringent condition shall be applicable.
- 6 Owner / Owner's representative including TPIA will have the right to inspect any activity of manufacturing at any time
- 7 All reference Codes/ Standards, Documents, P.O. Copies shall be arranged by vendor / supplier for reference of TPIA/HOGPL at the time of Inspection
- 8 At the time of delivery of material in stores, vendor will submit copy of all related document of inspection along with release note & MTC.
- 9 All Tests shall be carried out as per EN-331. However, other additional tests, which are not covered in EN-331, shall be carried out as per ASME B16.33.



INSPECTION AND TEST PLAN – FLANGES SPECTACLE BLINDS & DRIP RINGS

INSPECTION AND TEST PLAN – FLANGES SPECTACLE BLINDS & DRIP RINGS

ABBREVIATIONS

CE	Carbon Equivalent	NPSH	Net Positive Suction Head
DFT	Dry Film Thickness	PO	Purchase Order
DPT	Dye Penetrant Testing	PESO	Petroleum Explosive Safety Organization
DHT	De-hydrogen Heat Treatment	PQR	Procedure Qualification Record
ERTL	Electronics Regional Test Laboratory	PR	Purchase Requisition
FCRI	Fluid Control Research Institute	PMI	Positive Material Identification
HT	Heat Treatment	RT	Radiography Testing
HIC	Hydrogen Induced Cracking	SSCC	Sulphide Stress Corrosion Cracking
ITP	Inspection and Test Plan	TC	Test Certificate
IP	Ingress Protection	TPI or TPIA	Third Party Inspection Agency
IHT	Intermediate Heat Treatment	UT	Ultrasonic Testing
IC	Inspection Certificate	VDR	Vendor Data Requirement
IGC	Inter Granular Corrosion	WPS	Welding Procedure Specification
MRT	Mechanical Run Test	WPQ	Welders Performance Qualification
NDT	Non Destructive Testing	MPT / MT	Magnetic Particle Testing

1.0 SCOPE:

This Inspection and Test Plan covers the minimum testing requirements of Flanges, Spectacle blinds & Drip Rings.

2.0 REFERENCE DOCUMENTS:

PO/PR/ Standards referred there in/ Job specifications /Approved documents.

3.0 INSPECTION AND TEST REQUIREMENTS:

SL. NO.	STAGE/ ACTIVITY	CHARACTERISTICS	QUANTUM OF CHECK	RECORD	SCOPE OF INSPECTION		
					SUB SUPPLIER	SUPPLIER	TPIA
1.0	Procedure						
1.1	Heat Treatment, NDT and Other Procedures	Documented Procedures	100%	Procedure Documents	-	H	R
1.2	WPS,PQR & WPQ	Welding Parameters & Qualification Record	100%	WPS,PQR & WPQ	-	H	W- New R- Existing
2.0	Material Inspection						
2.1	Raw Material Inspection	Chemical & Mechanical Properties	100%	Test Certificates	-	H	R

3.0	In Process Inspection						
3.1	Welding / Forging	Forging /Welding Parameters	100%	Inspection Reports	-	H	-
3.2	Heat Treatment	Stress Relieving, Normalising, Tempering, Solution Annealing, Stabilization Heat Treatment etc. as applicable	100%	HT chart	-	H	R
3.3	Identification of Test Samples	Product Chemical, Mechanical, Impact, IGC and Other test as applicable	100%	Test Reports	-	H	H(Note-1)
3.4	Product Analysis (As applicable)	Chemical Composition	As per PR/Purchase Specification	Test Reports	-	H	R
3.5	Destructive Testing	Mechanical, Impact, IGC and Other test as applicable	100%	Test Reports	-	H	H(Note-1)
3.6	NDT as applicable	Surface & Internal Imperfections	As per PR/Purchase Specification	NDT Reports	-	H	R
3.7	Galvanizing (If Applicable)	Integrity Of Galvanised Coating	100%	Inspection Report	-	H	-
4.0	Final Inspection						

4.1	Final Inspection	1. Visual 2. Dimensions 3. Hardness 4. Marking etc	100%	Inspection report	-	H	H(Note-1)
4.2	PMI Check	Chemical Check	As Per VCS Spec.	Inspection report	-	H	RW
4.3	Final Stamping	Stamping of accepted Items	Stamping of Items which are witnessed by TPIA.	Inspection report	-	H	H(Note-1)
5.0	Painting						
5.1	Rust Preventive Coating & Colour Coding	Visual Inspection & Colour Coding as applicable	100%	Inspection report	-	H	-
6.0	Documentation & IC						
6.1	Documentation & Inspection Certificate(IC)	Review of Stage Inspection Reports / Test Reports & Issue of IC	100%	Supplier TC & IC	-	H	H

Legend:

H - Hold (Do not proceed without approval),

P - Perform,

RW - Random Witness (As specified or 10% [min.1 no. of each size and type of Bulk item]),

R - Review,

W - Witness (Give due notice, work may proceed after scheduled date).PR- PURCHASE REQUISITION

NOTES (As applicable):

1. For Non NACE & Non Hydrogen service Carbon Steel Flanges, Spectacle Blinds & Drip Rings up to size 24"-300ANSI Class Will be accepted on review of Supplier Test Certificates. Supplier Test Certificate to be reviewed by TPIA.
2. This document describes the generic test requirements. Any additional test or Inspection scope if specified in contract documents shall also be Applicable (unless otherwise agreed upon).
3. Acceptance Norms for all the activities shall be as per PO/PR/STANDARDS referred there in /Job Specification /Approved Documents.
4. For orders placed on stockist, items shall be accepted based on manufacturer's TC with EN310204 type 3.2 certification from VCS / OWNER approved suppliers.



QUALITY CONTROL TABLES
GI PIPES CONFORMING TO IS:1239 (PART-1):2004 (Latest edition)

S.N O.	COMPONENTS /OPERATIONS	CHARACHTERISTICS	CLASSIFICATION	TYPE OF CHECK	QUANTUM OF CHECK	REFERENCE DOCUMENTS	ACCEPTANCE NORMS	FORMAT OF RECORD	VENDOR	TPIA
1	2	3	4	s	6	7	8	9	10	11
1	Raw Material Inspection									
1.1	RAW MATERIAL	IDENTIFICATION	Major	Co-relation with MTC.	100%	IS: 1239 / P.O. Spec.	IS: 1239 / P.O. Spec.	T.C.	p	R
		CHEMICAL COMPOSITION	Major	Chern. Analysis	One I Heat	IS: 1239 / P.P. Spec.	IS: 1239 / P.O. Spec.	IIR	p	R
		PHYSICAL PROPERTIES (T.S., Y.S., % Elong.)	Major	Lab. Test	One/ Heat	IS: 1239 / P.O. Spec.	IS: 1239 / P.O. Spec.	IIR	p	R
		VISUAL & DIMENSIONS	Major	Visual & Measur.	100%	IS: 1239 / P.O. Spec.	IS: 1239 / P.O. Spec.	IIR	p	R
2	IN P'ROCESS INSPECTION									
2.1	PIPE MANUFACTURING	SURFACE DEFECT	Major	Visual	100%	IS:1239/P.O. Spec.	IS: 1239 / P.O. Spec.	IIR	p	R
		DIMENSIONS (O.D., THK., LENGTH etc.)	Major	Measure.	As Per Relevant Std.	IS: 1239 / P.O. Spec.	IS: 1239 / P.O. Spec.	IIR	p	R
		MASS (Kg Mtr.)	Major	Measure.	As Per Relevant Std.	IS: 1239 / P.O. Spec.	IS:1239/P.O. Spec.	IIR	p	R
2.2	END PREPARATION	END TYPE & DIMENSIONS	Major	Visual & Measur.	100%	IS: 1239 / P.O. Spec.	IS:1239/P.O. Spec.	IIR	p	R
2.3	PHYSICAL PROPERTIES	TENSILE, ELONGATION & BEND I FLATTENING TEST AS APPLICABLE	Major	Lab. Test	As Per Relevant Std.	IS: 1239 / P.O. Spec.	IS: 1239 / P.O. Spec.	IIR	p	R
2.4	LEAK TEST	HYDRAULIC	Critical	Leak Test	100%	IS: 1239 / P.O. Spec.	IS: 1239 / P.O. Spec.	IIR	p	w
2.5	GALVANIZING	ZINC COATING UNIFORMITY & MASS	Major	Mass of Zinc Coating & Uniformity	2 Sample I Shift	IS: 4736	IS: 4736	IIR	p	w
2.6	FINISH, PAINTING & MARKING	OVERALL FINISH, PAINTING & MARKING	Major	Visual	100%	IS: 1239 / P.O. Spec.	IS: 1239 / P.O. Spec.	IIR	p	R



QUALITY CONTROL TABLES
GI PIPES CONFORMING TO IS:1239 (PART-1):2004 (Latest edition)

S.No.	COMPONENTS/ OPERATIONS	CHARACTERISTICS	CLASSIFICATION	TYPE OF CHECK	QUANTUM OF CHECK	REFERENCE DOCUMENTS	ACCEPTANCE NORMS	FORMAT OF RECORD	VENDOR	TPI A
1	2	3	4	5	6	7	8	9	10	11
3	FINAL INSPECTION									
3.1		FINISH DIMENSIONS	Major	Visual & Measur.	Random As Per IS:4711	IS: 1239 / P.O. Spec.	IS: 1239 / P.O. Spec.	IR	p	w
	FINISHED PRODUCT	PHYSICAL PROPERTIES (TENSILE, ELONGATION & BEND / FLATTENING TEST AS APPLICABLE)	Major		Random As Per IS:4711	IS: 1239 / P.O. Spec.	IS: 1239 / P.O. Spec.	IR	P	w
		LEAK TEST (HYDRAULIC TEST)	Critical	Leak Test	Randomly (10% of lot qty)	IS: 1239 / P.O. Spec.	IS: 1239 / P.O. Spec.	IR	P	w
		REVIEW OF ALL TEST CERTIFICATE / REPORTS & VENDOR'S IIR	Major	Review	-	IS:1239/ P.O. Spec., EN 10204	IS:1239/ P.O. Spec., EN	R	p	R

LEGENDS H-HOLD P-PERFORMANCE R-REVIEW W-WITNESS TC-TEST CERTIFICATE IIR-INTERNAL INSPECTION R-REPORT CA-CONTROL AUTHORITY TPIA - THIRD PARTY INSPECTION AGENCY

- The above testing and acceptance criteria are minimum requirements; however, manufacturer shall ensure that the product shall also comply to the additional requirements as per Particular Technical specifications (PTS).
- The supplier shall submit their own detailed ITP prepared on the basis of above I Technical specification for approval of Owner/ Owner's representative.
- Owner / Owner representative shall review / approve all the documents related to ITP / Quality manuals / Drawings etc. submitted by supplier
- Contractor shall in coordination with Supplier / Sub vendor issue detailed Production and Inspection schedule indicating the dates and the locations to facilitate Owner / Owner's representative and TPIA to organize Inspection
- Special manufacturing procedures have to be specially approved or only previously approved procedures have to be used in case of conflict between specifications more stringent condition shall be applicable.
- Owner/Owner's representative including TPIA will have the right to inspect any activity of manufacturing at any time.
- All reference Codes / Standards. Documents, P.O. Copies shall be arranged by vendor / supplier for reference of TPIA / HOGPL at the time of inspection.
- At the time of delivery of material in stores, vendor will submit copy of all related document of inspection along with release note, dispatch clearance note & MTC.



QUALITY CONTROL TABLES GI FITTINGS

SR. No	DESCRIPTION	COMPONENT	CHARACTERISTICS	QUANTUM OF CHECK	REF. DOC.	ACCEPTANCE NORMS	RECORD	INSPECTION			REMARKS
								MANUF.	TPIA	CA	
1	Chemical composition of material	Test Bar	Marking and correlation	IS: 14329 Grade BM 300	PO, Material specification	IS 14329/ PO, Material specifications	Mill TC	R	R	R	
2	Chemical composition of Final product	Fitting	Chemical properties	IS: 14329 Grade BM 300	PO, Material specification	IS 14329/ PTS	TC	P	E	R	
3	Cleaning and Flushing	Fitting	Descaling	100%	IS 14329/ PTS	IS 14329/ PTS	Inspection Report	W	RW	R	
4	Destructive Testing (Tensile, Elongation & Hardness)	Fitting	Mechanical Properties	IS 14329	IS 14329/ PTS	IS 14329/ PTS	Lab Report	W	W	RW	
5	Compression Test	-	Malleability	Three samples per Heat	IS 1879/ PTS	IS 1879/ PTS	Inspection Report	P	W	RW	
6	Pressure Test	-	-	IS 1879	IS 1879/ PTS	IS 1879/ PTS	Inspection Report	P	W	RW	As per sampling procedure of IS 1839
7	Alignments of Thread	-	-	IS 1879	IS 1879/ PTS	IS 1879/ PTS	Inspection Report	P	W	RW	
8	Galvanizing	Fitting	Integrity of galvanised coating	As listed in IS 4759	IS 4736/ PTS	PTS	Inspection / Lab Report	W	W	RW	
9	Final inspection	Fitting	Visual, Dimensions, Finish, weld bevel, Bore, Marking, Colour coding	IS 1879	IS 1879/ PTS	IS 1879/ PTS	Inspection Report	W	W	R	
10	Marking	-	-	100%	PTS	PTS	Inspection Report	P	R	R	
11	Documentation	-	-	-	As per the terms and conditions of the PO & PTS	As per the terms and conditions of the PO & PTS	Compliance certificate	-	-	-	

LEGENDSH-HOLD P-PERFORMANCE REPORT R-REVIEW CA-CONTROL AUTHORITY TPIA-THIRD PARTY INSPECTION AGENCY W-WITNESS TC-TEST CERTIFICATE IIR-INTERNAL INSPECTION

- The above testing and acceptance criteria are minimum requirements, however, manufacturer shall ensure that the product shall also comply to the additional requirements as per Particular Technical specifications(PTS)
- The supplier shall submit their own detailed ITP prepared on the basis of above I Technical specification for approval of Owner / Owner's representative
- Owner / Owner representative shall review / approve all the documents related to ITP / Quality manuals / Drawings etc. submitted by supplier
- Contractor shall in coordination with Supplier / Sub vendor issue detailed Production and Inspection schedule indicating the dates and the locations to facilitate Owner / Owner's representative and TPIA to organize Inspection
- Special manufacturing procedure shall have to be specially approved or only previously approved procedures have to be used, in case of conflict between specifications more stringent condition shall be applicable.
- Owner/ Owner's representative including TPIA will have the right to inspect any activity of manufacturing at any time.
- All reference Codes / Standards documents, P.O. Copies shall be arranged by vendor I supplier for reference of TPIA / HOGPL at the time of inspection.
- At the time of delivery of material in stores, vendor will submit copy of all related document of inspection along with release note, dispatch clearance note & MTC.



QUALITY CONTROL TABLES COPPER TUBE

						INSPECTION			
SR. No	DESCRIPTION	QUANTUM CHECK	OF	PROCEDURE	ACCEPTANCE CRITERIA (As per EN 1057/ PTS)	FORMAT OF RECORD	VENDOR	TPIA/ CLIENT	REMARKS
1	Raw material: Chemical Requirement	As per EN 1057		As per EN 1057	Material grade Cu-DHP/ CW 024A Cu + Ag : Min 99.9% P: 0.0015% TO 0.040%	MTC	P	R	
2	Final product: Chemical Requirement	As per EN 1057		As per EN 1057		Inspection Report	P	W	
3	Physical test (Tensile, Elongation, Hardness etc.)	As per EN 1057		As per EN 1057	UTS- Min. 250 N/ Sq.mm Elongation - Min 30% Hardness- 75 to 100 HV	Inspection Report	P	W	
4	Carbon film tets	As per EN 1057		As per EN 1057	Maximum Residual carbon- 0.20 mm/ sq. dm	Inspection Report	P	W	
5	Carbon content test	As per EN 1057		As per EN 1057	As per EN 1057/ PTS	Inspection Report	P	W	
6	Drift expanding test	As per EN 1057		As per EN 1057	As per EN 1057/ PTS	Inspection Report	P	W	
7	Hydrostatic test	As per EN 1057		As per EN 1057	Min 35 bar/ 10 second	Inspection Report	P	W	
8	Eddy current test	As per EN 1057		As per EN 1057	As per EN 1057/ PTS	Inspection Report	P	W	
9	Dimensional Inspection (O.D, Wllthk, Length etc.)	As per EN 1057		As per EN 1057	As per EN 1057/ PTS	Inspection Report	P	W	
10	Visual Inspection (Free from defect)	As per EN 1057		As per EN 1057	As per EN 1057/ PTS	Inspection Report	P	R	
11	Marking	As per EN 1057		As per EN 1057	As per EN 1057/ PTS	Inspection Report	P	R	
12	Documentation	-		As per EN 1057	As per EN 1057/ PTS	Inspection Report	P	R	

LEGENDS H-HOLD W- WITNESS P- PERFORM TPIA- THIRD PARTY INSPECTION AGENCY CA- CONTROL AUTHORITY

1. The above testing and acceptance criteria are minimum requirements; however, manufacturer shall ensure that the product shall also comply to the additional requirements as per specification.
2. The supplier shall submit their own detailed ITP prepared on the basis of above I Technical specification for approval of Owner / Owner's representative.
3. Owner/ Owner representative shall review/ approve all the documents related to ITP / Quality manuals / Drawings etc. submitted by supplier
4. Contractor shall in coordination with Supplier / Sub vendor issue detailed Production and Inspection schedule indicating the dates and the locations to facilitate Owner / Owner's representative and TPIA
5. Special manufacturing procedures have to be specially approved or only previously approved procedures have to be used, in case of conflict between specifications more stringent
6. Owner / Owner's representative including TPIA will have the right to inspect any activity of manufacturing at any time.
7. All reference Codes / Standards. Documents, P.O. Copies shall be arranged by vendor I supplier for reference of TPIA/ HOGPL at the time of inspection.
8. At the time of delivery of material in stores, vendor will submit copy of all related document of inspection along with release note, dispatch clearance note & MTC.



QUALITY CONTROL TABLES COPPER FITTINGS

						INSPECTION		
SR. No	DESCRIPTION	QUANTUM OF CHECK	PROCEDURE	ACCEPTANCE CRITERIA (As per EN 1057/ PTS)	FORMAT OF	VENDOR	TPIA/ CLIENT	REMARKS
1	Raw material: Chemical Requirement	one in each heat	As per EN 1254	Material grade Cu-DHP/ CW 024A Cu + Ag : Min 99.9% P: 0.0015% TO 0.040%	MTC	P	R	
2	Final product: Chemical Requirement	one in each heat	As per EN 1254		Test Report	P	W	
3	Carbon in bore tssets (Carbon film test, carbon content test)	one in each heat	As per EN 1254	As per EN 1254/ PTS	Test Report	P	W	
4	Stress corrosion resistance test	one in each heat	As per EN 6957	As per ISO 6957/ PTS	Test Report	P	W	
5	Hysrostatic pressure test	100%	As per EN 1254	Min 37.5 bar @ 15 min.	Test Report	P	W	
6	Pneumatic pressure test	100%	As per EN 1254	Min 6 bar @ 10 second	Test Report	P	W	
7	Dimensional Inspection (O.D, Wlthk, Length etc.)	100%	As per EN 1254	As per EN 1254/ PTS	Test Report	P	W	
8	Visual Inspection (Free from defect)	100%	As per EN 1254	As per EN 1254/ PTS	Test Report	P	R	
9	Marking	100%	As per EN 1254	As per EN 1254/ PTS		P	R	
10	Documentation	-	As per EN 1254	As per EN 1254/ PTS	Inspection Report	P	R	

LEGENDS H-HOLD W-WITNESS P-PERFORM TPIA- THIRD PARTY INSPECTION AGENCY CA- CONTROL AUTHOIRTY

1. The above testing and acceptance criteria are minimum requirements; however, manufacturer shall ensure that the product shall also comply to the additional requirements as per specification.
2. The supplier shall submit their own detailed ITP prepared on the basis of above I Technical specification for approval of Owner / Owner's representative.
3. Owner/ Owner representative shall review/ approve all the documents related to ITP / Quality manuals / Drawings etc. submitted by supplier
4. Contractor shall in coordination with Supplier / Sub vendor issue detailed Production and Inspection schedule indicating the dates and the locations to facilitate Owner / Owner's representative and TPIA
5. Special manufacturing procedures have to be specially approved or only previously approved procedures have to be used, in case of conflict between specifications more stringent
6. Owner / Owner's representative including TPIA will have the right to inspect any activity of manufacturing at any time.
7. All reference Codes / Standards. Documents, P.O. Copies shall be arranged by vendor I supplier for reference of TPIA/ HOGPL at the time of inspection.
8. At the time of delivery of material in stores, vendor will submit copy of all related document of inspection along with release note, dispatch clearance note & MTC.



QUALITY CONTROL TABLES BRASS FITTINGS

SR. No	DESCRIPTION	QUANTUM OF CHECK	PROCEDURE	ACCEPTANCE CRITERIA (As per EN 1057/ PTS)	FORMAT RECORD	INSPECTION		REMARKS
						VENDOR	TPIA/ CLIENT	
1	Raw material: Chemical/ Physical Requirement	one in each heat	As per EN 2164	As per EN 12164/ PTS	MTC	P	W	Preferably witness by CA
2	Final product		As per EN 2164			P	W	
3	Resistance dezincification	one in each heat	As per EN 6957	As per EN 1254	Test Report	P	W	
4	Carbon bore test	one in each heat	As per EN 2164	As per ISO 6957/ PTS	Test Report			
5	Stress corrosion resistance test	one in each heat	As per EN 2164	As per ISO 1254/ PTS	Test Report	P	W	
6	Hysrostatic pressure test	100%	As per EN 2164	Min 37.5 bar @ 15 min.	Test Report	P	W	Preferably witness by CA
7	Pneumatic pressure test	100%	As per EN 12164	Min 6 bar @ 15 second	Test Report	P	W	Preferably witness by CA
8	Visual Inspection (Free from defect)	100%	As per EN 12164	As per EN 1254/ PTS	Test Report	P	R	
9	Dimensional Inspection (O.D, Wllthk, Lengthetc.)	100%	As per EN 12164	As per EN 1254/ PTS	Test Report	P	W	
10	Marking	100%	As per EN 12164	As per EN 1254		P	R	
11	Documentation	-	PO/ PTS	PO/ PTS	Test Report	P	H	

LEGENDS H-HOLD W-WITNESS P-PERFORM TPIA- THIRD PARTY INSPECTION AGENCY CA- CONTROL AUTHORITY

- The above testing and acceptance criteria are minimum requirements; however, manufacturer shall ensure that the product shall also comply to the additional requirements as per specification.
- The supplier shall submit their own detailed ITP prepared on the basis of above I Technical specification for approval of Owner / Owner's representative.
- Owner/ Owner representative shall review/ approve all the documents related to ITP / Quality manuals / Drawings etc. submitted by supplier
- Contractor shall in coordination with Supplier / Sub vendor issue detailed Production and Inspection schedule indicating the dates and the locations to facilitate Owner / Owner's representative and TPIA
- Special manufacturing procedures have to be specially approved or only previously approved procedures have to be used, in case of conflict between specifications more stringent
- Owner / Owner's representative including TPIA will have the right to inspect any activity of manufacturing at any time.
- All reference Codes / Standards. Documents, P.O. Copies shall be arranged by vendor I supplier for reference of TPIA/ HOGPL at the time of inspection.
- At the time of delivery of material in stores, vendor will submit copy of all related document of inspection along with release note, dispatch clearance note & MTC.



QUALITY CONTROL TABLES STEEL REINFORCED RUBBER HOSE

SR. No	DESCRIPTION	TEST PARAMETERS	QUANTUM OF CHECK	PROCEDURE	ACCEPTANCE CRITERIA (As per EN 1057/ PTS)	CERTIFICATE	INSPECTION		REMARKS
							VENDOR	TPIA/ CLIEN	
	Raw Material	Chemical & Mech Test of material os Steel Reinforced Rubber Hose (Lining, Reinforced material &	100%	IS 9573	IS 9573	MTC	P	R	
	Final Product								
4	Final Inspection	Mechanical Properties	one (1) per batch	Tensile Strength = 10Mpa (Min.) El (Lining & Cover) is 200 & 250 resp.	PTS & IS 9573	Inspection Report	P	W	
5		Resistance of Lining to n-pentane	one (1) per batch	Shall not exceed 10% absorbed & 5% extractable as per Cl. No. 5.2 of	Cl. 5.4.3.2 of IS 9573	Inspection Report	P	W	
6		Adhesion Test	one (1) per batch	Min. Adhesion shall be 2 KN/m as Cl.	Cl. 5.5.1 of IS 9573	Inspection Report	P	W	
7		Low Temperature Flexibility Test	One (1) per batch	Conditioned at -40 deg for 50 hours and bent at 180 deg around mandrel of dia 12 times the Nominal Bore of hose as per Cl no. 5.4 of PTS	Cl. 5.5.2 of IS 9573	Inspection Report	P	W	
8		Flexibility of hose at 1.5 x design pressure	one (1) per batch	Bend empty to radius 95 mm without Flattening & suffering structural damages.	Cl. 5.5.3 of IS 9573	Inspection Report	P	W	Witness by CA
		Ozone Resistance Test	one (1) per batch	Cl. No 5.9 of PTS	Cl. 5.5.4 of IS 9573	Inspection Report	P	W	Witness by CA
		Hydrostatic/ Proof Pr. Test	100%	min. as per Cl. No. 5.7 of PTS	Cl. 5.5.1 of IS 9573	Inspection Report	P	W	Witness by CA
		Burst test	one (1) per batch	Cl. No. 5.9 of PTS	Cl. 5.5.2 of IS 9573	Inspection Report	P	W	
		Grip Strength test	one (1) per batch		Cl. 5.5.7 of IS 9573 & Annex A of IS 9573	Inspection Report	P	W	
		Burning Test	one (1) per batch	rn till 45 sec. as per Cl. No. 5.10	Cl. 5.5.8 of IS 9573	Inspection Report	P	W	
	Visual & dimensional check	100%	No. 4.0 of PTS & IS 9573	IS 9573	Inspection Report	P	R		
9	Cover color- Orange	100%	Cl. No. 5.2.3 of PTS	PTS & IS 9573	Inspection Report	P	R		
	Enf Fittings (Adaptors, nuts, washer)	-	100%	s per Cl. No. 6.0 of PTS	PTS & IS 9573	Inspection Report		R	
10	Marking	-	100%	s per Cl. No. 7.0 of PTS	PTS & IS 9573	Inspection Report	P	R	
11	Documentation	-	-	& conditions of P.O & PTS	As per term & conditions of P.O & PTS	3.2 Certification as per EN 1024	P	H	

LEGENDS H-HOLD W-WITNESS P-PERFORM TPIA- THIRD PARTY INSPECTION AGENCY CA- CONTROL AUTHORITY

1. The above testing and acceptance criteria are minimum requirements; however, manufacturer shall ensure that the product shall also comply to the additional requirements as per specification.
2. The supplier shall submit their own detailed ITP prepared on the basis of above I Technical specification for approval of Owner / Owner's representative.
3. Owner/ Owner representative shall review/ approve all the documents related to ITP / Quality manuals / Drawings etc. submitted by supplier
4. Contractor shall in coordination with Supplier / Sub vendor issue detailed Production and Inspection schedule indicating the dates and the locations to facilitate Owner / Owner's representative and TPIA
5. Special manufacturing procedures have to be specially approved or only previously approved procedures have to be used, in case of conflict between specifications more stringent
6. Owner / Owner's representative including TPIA will have the right to inspect any activity of manufacturing at any time.
7. All reference Codes / Standards. Documents, P.O. Copies shall be arranged by vendor I supplier for reference of TPIA/ HOGPL at the time of inspection.
8. At the time of delivery of material in stores, vendor will submit copy of all related document of inspection along with release note, dispatch clearance note & MTC.

**CITY GAS DISTRIBUTION PROJECT AT
KOLHAPUR GA**



TOTAL SHEETS

2

LIST OF RECOMMENDED TPIA

LIST OF RECOMMENDED THIRD PARTY INSPECTION AGENCY (TPIA)

SL. NO	NAME OF TPI	ADDRESS	PHONE NO	FAX NO
1	Tata Projects Ltd.	22,Sarvodaya Society,Nizampura,Baroda-390002	0265-2392863	0265-2785952
2	Bax counsel Insepection Bureau Pvt. Ltd.	303, Madhava,Bandra Kurla Complex, Bandra(E),Mumbai-400051	022-26591526,022-26590236	022-26591526
3	Germanischer Lloyd	4th Floor, Dakshna Building, Sec-11, Plot NO.2, CBD Belapur, Navi Mumbai 400 614	022-4078 1000	022-4024 2935
4	ABS Industrial Verification Ltd., Mumbai	404,Mayuresh Chambers,Sector-11,CBD Belapur(E),Navi Mumbai-400614	022-27578780 /1 /2	022-27578784 / 5
5	Certification Engineers International Ltd.	EIL Bhavan,5th floor,1,Bhikaji Camma Place,New Delhi-110066	011-26167539,26102121	011-26101419
6	Dalal Mott MacDonald	501, Sakar -II, Ellisbridge,Ahemedabad-380006	079-26575550	079-6575558
7	International Certification Systems	E-7,Chand Society, Juhu Road, Juhu, Mumbai-4000049	022-26245747	022-226248167
8	SGS India Pvt. Ltd	SGS India Pvt. Ltd.,SGS House,4B,A.S.Marg,Vikhroli(W),Mumbai-400083	022-25798421 to 28	022-25798431 to 33
9	Intertek Moody	9th Floor, Kanchenjunga Building, 18-Barakhamba Road, New Delhi-110001	011-4713 3900	011-4713 3999
10	TUV SUD South Asia	C-153/1, Okhla Industrial Ara, Phase-1, New Delhi-110020	011-3088 9611/9797	011-3088 9598
11	TUV Rheinland (India) Pvt. Ltd.	F-51, Kailash Complex GF, Veer Savarkar Marg, Vikhroli Park Site, Vikhroli(W), Mumbai-400079	022-4215 5435	022-4215 5434
12	Vincott International India Assessment Service Pvt. Ltd.	C-301, Mangalya Premises Cooperative Soc. Ltd, Off. Marol Maroshi Road, Andheri(E), Mumbai-400959	022-4247 4100	022-4247 4101
13	Meenar Global Consultants	Mr. Nitin Taneja (Project Manager)	M: +91-9711212783 T: +91-129-4072836	Web : www.meenaar.in Email : nitin.taneja@meenaar.in
14	TUV Nord Group	-		-
15	DET NORSE VERITAS (DNV)	-	-	-
16	LLOYD Register			

APPROVED VENDOR LIST

APPROVED VENDOR LIST

ITEM CODE / DESCRIPTION	GI Pipe
VENDOR NAME	Remark
M/s Swastik Pipe Ltd.	
M/s Jindal Industries Ltd.	
M/s Vishal Pipes Ltd.	
M/s Indus Tubes Ltd.	
M/s Advance steel Tubes Ltd.	
M/s Good Luck Tubes Ltd.	
ITEM CODE / DESCRIPTION	GI fittings
VENDOR NAME	REMARKS
M/s Sarin Industries Ltd.	
M/s Jupiter Metal Industries Ltd.	
M/s Jainsons Industries Ltd.	
ITEM CODE / DESCRIPTION	Copper tubes & Fittings
VENDOR NAME	REMARKS
M/s Rajco metal	
M/s Mehta tubes	
ITEM CODE / DESCRIPTION	Brass Fittings
VENDOR NAME	REMARKS
M/s Chandan Enterprises	
M/s Paras Industries Ltd.	
ITEM CODE / DESCRIPTION	Steel Re-inforced Rubber Hose(Type-4)
VENDOR NAME	REMARKS
M/s Super Seal Flexible Hose	
M/s Suraksha Products Pvt. Ltd.	
M/s Vansh Industries	
M/s T & L Gases	



**LIST OF RECOMMENDED VENDORS FOR
BOUGHT OUT ITEMS**

TOTAL SHEETS

42

**LIST OF RECOMMENDED VENDORS FOR
BOUGHT OUT ITEMS**

LIST OF RECOMMENDED VENDER/SUPPLIERS OF MAJOR BOUGHT-OUT ITEMS

MECHANICAL & FIRE FIGHTING EQUIPMENT

i) Pipe Carbon Steel To Indian Standards

1. A.S.T. Pipes Pvt. Ltd. (AST Group)
2. Advance Steel Tube Ltd.
3. Apl Apollo Tubes Ltd. (Er. Bihar Tubes Ltd.
4. Asian Mills Pvt. Ltd.
5. Asrani Tubes Limited
6. Dadu Pipes (P) Ltd.
7. Essar Steel Limited(Er Hazira Pipes Mill)
8. Gaurang Products Pvt Ltd. (Ast Group)
9. Goodluck Steel Tubes Ltd.
10. Hi-Tech Pipes Limited
11. Indus Tube Limited
12. Jindal Industries Ltd
13. Jindal Pipes Ltd.
14. Jindal Saw Ltd (Kosi Works)
15. Jotindra Steel & Tube Ltd
16. Lalit Pipes And Pipes Ltd.
17. Maharashtra Seamless Ltd.
18. Man Industries (India) Ltd. – Pithampur
19. Man Industries (India) Ltd. Anjar
20. Mukat Tanks & Vessels Ltd.
21. Nezone Tubes Limited
22. North Eastern Tubes Limited
23. Pratibha Industries Limited
24. Pratibha Pipes & Structural Ltd.
25. Psl Ltd (Chennai)
26. Psl Ltd (V1, V2 & Nc)
27. Rama Steel Tubes Ltd.
28. Ratnamani Metals And Tubes Ltd.
29. Ravindra Tubes Limited

30. Samshi Pipe Industries Limited
31. Surya Roshni Ltd.
32. Swastik Pipes Ltd.
33. Utkarsh Tubes & Pipes Ltd. (Formly Bmw)
34. Welspun Corp. Limited (Dahej)
35. Zenith Birla (India) Limited

ii) Pipe & Tubulars To A.P.I. Standards

1. Arcelormittal Tubular Products Roman Sa, Romania
2. Bhel (Trichy),India
3. Dalmine Spa (Enquiry To Tenaris),Uae
4. Eewkorea Co. Ltd (Germany), Korea
5. Eew Korea Co. Ltd. (Korea), Korea
6. Eisenbau Kramer Gmbh, Germany
7. Hyundai Rb Co. Ltd. South Korea
8. Ilva Lamiere E Tubi Srl (Enq To Ilva Spa, Italy
9. Inox Tech. Spa, Italy
10. Ismt Ltd. Ahmedngr, India
11. Ismt Ltd. Baramati, India
12. Jindal Pipes Ltd., India
13. Jindal Saw Ltd. (Kosi Works), India
14. Jindal Saw Ltd. (Nashik Works), India
15. Lalit Pipes And Pipes Ltd. India
16. Maharashtra Seamless Ltd., India
17. Man Industries (I) Ltd. (Pithampur), India
18. Mukat Tanks & Vessels Ltd., India
19. Pratibha Industries Limited, India
20. Ratnamani Metals And Tubes Ltd., India
21. Siderca S.A.I.C (Enquiry Totenaris), Uae
22. Sumitomo Metal Ind. Ltd., India
23. Surya Roshni Ltd., India
24. Swastik Pipes Ltd, India
25. Tata Steel Uk Limited (Formerly C702)
26. Tubos De Acero De Mexico Sa (Enq. Tenaris), Uae
27. Tubos Reunidos Sa Spain

28. Umran Steel Pipe Inc (Turkey), Turkey
29. Valcovny Trub Chomutov, Czech Republic
30. Vallourec And Mannesmann Tubes, France
31. Welspun Corp Limited (Dahej), India

iii) Pipe/Tube CS (Seamless) To ASTM Stds

1. Arcelormittal Tubular Products Roman Sa, Romania
2. Bhel (Trichy), India
3. Changshu Seamless Steel Tube Co. Ltd., China
4. Dalmine Spa (Enquiry To Tenaris, Uae
5. Heavy Metals & Tubes Limited (Mehsana), India
6. Ismt Ltd. Ahmedngr, India
7. Ismt Ltd. Baramati India
8. Jfe Steel Corporation, Uae
9. Jindal Sdaw Ltd (Nashik Works) India
10. Klt Automotive And Tubular Products Ltd., India
11. Mahalaxmi Seamless Limited, India
12. Maharashtra Seamless Ltd, India
13. Products Tubulares S.A.U, Spain
14. Ratnadeep Metal Tubes Ltd., India
15. Staineest Tubes Pvt Ltd., India
16. Sumitomo Metal Ind. Ltd., India
17. Tubos Reunidos Sa Spain
18. Valcovny Trub Chomutov, Czech Republic
19. Vallourec Andmannesmann Tubes France
20. Yangzhou Chengde Steel Pipe Co. Ltd Dubai (UAE)

iv) Pipe Carbon Steel (Welded) To ASTM Stds

1. Eew Korea Co. Ltd. (Germany), Korea
2. Eew Korea Co. Ltd. (Korea), Korea
3. Eisenbau Kramer Gmbh, Germany
4. Hyundai Rb Co. Ltd., South Korea
5. Inox Tech. Spa, Italy
6. Jindal Saw Ltd (Kosi Works), India
7. Lalit Pipes and Pipes Ltd., India

8. Man Industries (I) Ltd.(Pithampur), India
9. Man Industries (India) Ltd. Anjar, India
10. Mukat Tanks & Vessels Ltd., India
11. Ratnamani Metals And Tubes Ltd., India
12. Sumitomo Metal India Ltd., India
13. Tata Steel Uk Limited

v) Valve

a) Globe Valves

- 1) M/S BDK (New Delhi)
- 2) M/S Datre Corpn (Calcutta)
- 3) M/S KSB Pumps (New Delhi)
- 4) M/S L&T (New Delhi)
- 5) M/S Neco Schuber & Salzer Ltd. (New Delhi)
- 6) M/S Niton Valve (Mumbai)
- 7) M/S Ornate Valves (Mumbai)
- 8) M/S Panchavati Valves (Mumbai)
- 9) AV Valves Ltd.
- 10) BHEL (Trichy), India
- 11) Econo Valves Pvt Ltd, India
- 12) Fouress Engg (I) Ltd (Aurangabad)
- 13) Guru Industrial Valves Pvt Ltd
- 14) Leader Valves Ltd, India
- 15) NSSL Ltd. (Neco Schubert & Salzerltd)
- 16) Oswal Industries Ltd, India
- 17) Petrochemical Engineering Enterprises, India
- 18) Sakhi Engineers Pvt Ltd
- 19) Shalimar Valves Pvt Ltd
- 20) Steel Strong Valves India Pvt Ltd, India
- 21) Petro Valves Pvt. Limited, Ahmedabad
- 22) Hawa Engineers Limited, Ahmedabad

b) Check Valves

1. M/s Advance Valves Pvt. Ltd., Noida

2. M/s Aksons & Mechanical Enterprises, Mumbai
3. M/s Larsen & Toubro Limited (M/s Audco India Limited, Chennai)
4. M/s AV valves Ltd., Agra
5. M/s BDK engineering India Ltd., Hubli
6. M/s BHEL, OFE&OE Group, New Delhi
7. M/s Datre Coroportion Limited, Calcutta
8. M/s Leader Valves Ltd., Jalandhar
9. M/s Neco schubert & Salzer Ltd., New Delhi
10. M/s Niton Valves Industries (P) Ltd., Mumbai
11. M/s Precision Engg.Co., Mumbai
12. Econo Valves Pvt Ltd, India
13. Fouress Engg (I) Ltd (Aurangabad)
14. KSB Pumps Ltd (Coimbatore), India
15. NSSL Ltd. (Neco Schubert & SalzerLtd)
16. Oswal Industries Ltd, India
17. Panchvati Valves & Flanges Pvt Ltd, India
18. Petrochemical Engineering Enterprises, India
19. Sakhi Engineers Pvt Ltd
20. Shalimar Valves Pvt Ltd
21. Steel Strong Valves India Pvt Ltd, India
22. Hawa Engineers Limited, Ahmedabad

c) Plug Valves

1. M/s Breda Energia Sesto Industria Spa, Italy
2. M/s Fisher Sanmar Ltd., Chennai
3. M/s Larsen & Toubro Ltd., New Delhi
4. M/s Nordstrom Valves, USA
5. M/s Serck Audco Valves, UK
6. M/s Sumitomo Corporation India Pvt. Ltd., New Delhi
7. M/s Z Corporation, Korea
8. M/s Hawa Valves (India) Pvt. Ltd., Mumbai
9. M/s Steel Strong Valves India Pvt. Ltd., Navi Mumbai
10. M/s Econo Valves
11. M/s Flow-Serve PTE (Mfr. SERCK), India

d) Ball Valves

1. M/s Hawa Valves (India) Pvt. Ltd, Navi Mumbai
2. M/s Larsen & Toubro, Delhi
3. M/s Microfinish Valves Pvt. Ltd., Noida
4. M/s Oswal Industries Ltd., Gandhi nagar
5. M/s Virgo Engineers Ltd., Delhi
6. M/s Boteli Valve Group Co. Ltd., China
7. M/s Cameron (Malaysia) SDN BHD, Malaysia
8. M/s Dafram S.P.A., Italy
9. M/s Fangyuan Valve Group Co. Ltd., China
10. M/s Franz Schuck GmbH, Germany
11. O.M.S. Saleri (Italy)
12. Pibi Viesse S.P.A (Italy)
13. Nuovo Pignone (Italy)
14. Perar S.P.A (Italy)
15. Pietro Fiorentini (Italy)
16. Cooper Cameron Valv Italy SRL-FRM, Italy
17. Petrol Valves SRL
18. Tormene Gas Technology S.P.A (VALVITALIA)
19. Petro Valves Pvt. Limited, Ahmedabad
20. Hawa Engineers Limited, Ahmedabad

vi) Flow Tee

- 1) M/s Coprosider SPA, Italy
- 2) M/s GEA Energy System India Limited, Chennai
- 3) M/s Multitex Filtration
- 4) M/s Pipeline Engineering, UK
- 5) M/s Scomark Engg. Limited (U.K.)
- 6) M/s Skeltonhall Limited, Engaland(U.K.)
- 7) M/s Technospecial SPA, Italy
- 8) M/s Tectubi SPA, Italy
- 9) M/s RMA Germany
- 10) M/s Pipefit Engineers Pvt. Ltd.

11) Vee Kay Vikram

vii) Split Tee

- 1) M/s Ipsco, Canda
- 2) M/s TD Willamsons, USA

viii) Flanges

1. M/s Aditya Forge Ltd., Vadodara
2. M/s Amforge Industries Ltd., Mumbai
3. M/s CD Engineering Co., Ghaziabad
4. M/s Echjay Forgings Pvt. Ltd. (Bombay), Mumbai
5. M/s Echjay Industries Ltd., Rajkot
6. M/s Forge & Forge Pvt. Ltd., Rajkot
7. M/s Golden Iron & Steel Works, New Delhi
8. M/s JK Forgings, New Delhi
9. M/s Metal Forgings Pvt. Ltd., Mumbai
10. M/s Perfect Marketings Pvt. Ltd., New Delhi
11. M/s Sky Forge, Faridabad
12. M/s S&G, Faridabad
13. Chaudhry Hammer Works Ltd, India
14. JAV Forgings (P) Ltd, India
15. Kunj Forgings Pvt Ltd, India
16. MS Fittings
17. R.N. Gupta & Co. Ltd, India
18. R.P. Engineering Pvt Ltd, India
19. Sanghvi Forgings & Engineering Ltd
20. Shri Ganesh Forgings Ltd., India
21. Uma Shankar Khandelwal & Co., India
22. Sawan Engineers, Baroda
23. Stewarts & Lloyds of India Ltd., Kolkata
24. Engineering Services Enterprises
25. Pipefit Engineers Pvt. Ltd.

ix) Fittings

1. M/s Commercial Supplying Agency, Mumbai
2. M/s Dee Development Engineers Ltd.
3. M/s Eby Industries, Mumbai
4. M/s Flash Forge Pvt. Ltd., Vishakhapatnam
5. M/s Gujarat Infra Pipes Pvt. Ltd., Vadodara
6. M/s M.S. Fittings Mfg. Co. Pvt. Ltd., Kolkata
7. M/s Stewarts & Lloyds of India Ltd., Kolkata
8. M/s Teekay Tubes Pvt. Ltd., Mumbai
9. M/s Pipe Fit, Baroda
10. M/s Sky Forge, Faridabad
11. M/s S&G, Faridabad
12. M/s Sawan Engineers, Baroda
13. Eby Fasteners, India
14. Leader Valves Ltd, India
15. R.N. Gupta & Co. Ltd, India
16. Exten Engg Pvt Ltd
17. Sivananda Pipe & Fittings Ltd
18. M/s Jindal Forging

x) MDPE Fittings & MDPE Valves,

1. M/s. Aliaxis,
2. M/s. George Fischer,
3. M/s. Al-Aziz,
4. M/s. Kimplas,
5. M/s. Banides,
6. M/s. Agru,
7. M/s. Friatech,
8. M/s. Plasson.

xi) Brass Valves

1. M/s Universal srl, Italy
2. M/s Tiemme Raccorderie Sede, Italy
4. M/s Enolgas Bonimu s.a.s., Italy
5. M/s Fratelli Fortis s.r.l, Italy
6. M/s Giacomo Climbrio, Italy

7. M/s Parker Hannifin S.P.A., USA
8. M/s Singapore Valve & Amp; Fittings Pte Limited, Singapore /Bengaluru
9. M/S Rubinetterie Utensilerie Bonomi (RUB), Italy
10. M/s Zhejiang Valogin Technology Co. Ltd., China,
11. M/s. Ningbo Zhiqing Industrial Co. Ltd., China,
12. M/s. Zhejiang Dunan Valve Co. Ltd.,
13. M/s. Ningbo Huaping, China.

xii) Gaskets

1. IGP Engineers (P) Ltd., Madras
2. Madras Industrial Products, Madras
3. Dikson & Company, Bombay
4. Banco Products (P) Ltd., Vadodara
5. Goodrich Gaskets Pvt Ltd
6. Starflex Sealing India Pvt Ltd, India
7. Teekay Meta Flex Pvt Ltd
8. UNIKLINGER Ltd
9. HEM Engg. Corp.
10. Unique Industrial Packing Pvt. Ltd.

xiii) Fasteners

1. Nireka Engg. Co. (P) Ltd., Calcutta
2. Precision Taps & Dies, Bombay
3. AEP Company, Vithal Udyoung Nagar
4. Fix Fit Fasteners, Calcutta
5. Precision Engg. Industries, Baroda
6. Echjay Forgings Pvt. Ltd., Bombay
7. Capital Industries, Bombay
8. Boltmaster India Pvt Ltd, India
9. Deepak Fasteners Limited, India
10. Fasteners & Allied Products Pvt Ltd, India
11. Hardwin Fasteners Pvt Ltd, India
12. J.J. Industries, India
13. Multi Fasteners Pvt Ltd, India
14. Nexo Industries, India

15. Pacific Forging & Fasteners Pvt Ltd, India
16. Pioneer Nuts & Bolts Pvt Ltd, India
17. Precision Auto Engineers, India
18. President Engineering Works, India
19. Sandeep Engineering Works, India
20. Syndicate Engineering Industries, India

xiv) Welding Electrodes for Pipeline/Piping work:

1. Lincon,
2. Böhler
3. D&H

xv) Strainers

1. Bombay Chemical Equipments
2. Gujarat Auto filed
3. Multitex Filtration Engineering Limited
4. Grand Prix Engineering Limited

xvi) Cold Applied Tapes

1. Denso GmbH
2. Raychem

xvii) Heat Shrinkable Sleeve/ Fibreglas reinforced Sleeve

1. Seal for life - Covalence
2. Canusa
3. CYG Changtong New Material Co. LTD, China

xviii) Stud Bolts with Nuts

1. Multi Thread Fasteners, Baroda
2. Darukhanwala
3. Precision Engineers, Baroda
4. Unbrako
5. TVC

xix) Warning Mat

1. M/s Sparco Multiplast Pvt. Ltd., Ahmedabad
2. M/s Singhal Industries , Ahemdabad
3. M/s Puja Packing, Mumbai
4. M/s Bina Enterprises, Mumbai
5. M/s Shree Vijay Wire & Cable Industries

xx) HDPE PIPES/DUCT

1. M/s Climax Synthetics (P) Ltd., Vadodra
2. M/s Indian Poly Pipes, Calcutta
3. M/s Jain Irrigation Systems Ltd., Jalgaon
4. M/s Kirti Industries (India) Ltd., Indore
5. M/s Ori Plast Limited, Calcutta
6. M/s Phoel Industries Limited, Delhi
7. M/s Sangir Plastics (P) Ltd., Mumbai
8. M/s Veekay Plast,Jaipur
9. M/s Kisan Irrigation
10. M/s Dutron Polymers Ltd.
11. M/s Manikya Plastichem (P) Ltd
12. M/s Himalyan Pipe Industries

xxi) DRY GAS FILTER & FILTER SEPERATOR

1. Grand Prix Fab (Pvt.) Ltd.(New Delhi)
2. Perry Equipment, USA
3. Faudi Filter, Germany
4. Forain S.r.l., Italy
5. ABB, Faridabad
6. Burgess Manning, USA
7. Multitex Filtration Engineers India
8. Triveni Plenty Engg. Ltd. (New Delhi)

9. Siirtec International Contractor S.P.A (Italy)
10. Flashpoint, Pune india
11. Filtration Engineers (I) Pvt Ltd, India
12. Gujarat Otofilt, India
13. Tormene Gas Technology
14. Ultrafilter (India) Pvt Ltd, India
15. Ravi Techno Systems Pvt Ltd, India
16. Siirtec Nigi S.P.A
17. Filtan Filter Anlagenbau Gmbh
18. Fairley Arlon BV
19. PECO Facet
20. EPE Epenstenner GMBH
21. Filtrex srl
22. Petromar Engineered Soln
23. Plenty Filter
24. Eurofiltec
25. PTI Technologies Inc

xxii) FILTER ELEMENT

1. Peco – Facet
2. Velcon
3. Pall – Filterite
4. Burgress Manning

xxiii) NDT Agency

1. NDT Services, Ahmedabad
2. GEECY Industrial Services Pvt. Ltd., Mumbai
3. Corrosion Control Services, Mumbai
4. Perfect Metal Testing & Inspection Agency, Calcutta
5. Inter Ocean Shipping Co., New Delhi
6. RTD, Mumbai
7. Sievert, Mumbai

8. X-Tech, Vizag
9. JYOTI NDT INSPECTION CO., Delhi
10. RXSINGH NDT SERVICES (OPC) PRIVATE LIMITE
11. Aditya NDT Services
12. SURYA NDT SERVICES.
13. NDT & Allied Services, Noida
14. RIYA NDT ENGINEERS, New Delhi
15. PD Engineering Inspection Services, Noida
16. TCR Engineering Services Pvt Ltd
17. Smart NDT
18. Technical Testing and Inspection Services
19. Inspection Technology

xxiv) GI Pipe

1. M/s Swastik Pipe Ltd.
2. M/s Jindal Industries Ltd.
3. M/s Vishal Pipes Ltd.
4. M/s Indus Tubes Ltd
5. M/s Advance steel Tubes Ltd.
6. M/s Good Luck Tubes Ltd.
7. M/s Surya Roshni Limited
8. M/s. APL Apollo Tubes Limited
9. M/s. Jindal Pipes Limited

xxv) CASTING GI fittings

1. M/s Sarin Industries Ltd.
2. M/s Jupiter Metal Industries Ltd.
3. M/s Jainsons Industries Ltd.
4. M/s Jinan Meide Casting Co. Ltd.
5. M/s. Green Malleable Pvt. Ltd.

xxvi) Forged GI fitting (for High rise Sigmoid)

1. M/s Jainsons Industries
2. M/s B.M. Meters Pvt. Ltd.

xxvii) Copper Tubes

1. M/s Jay Banas M/s Mehta Tubes Limited- Trade Mark "MEXFLOW"

2. M/s Rajco metal (Tubes & Fittings)
3. M/s.Paras Industries
4. M/S MERCURE METAL & ALLOYS PVT LTD

xxviii) Brass Fittings

1. M/s Chandan Enterprises
2. M/s Paras Industries Ltd.
3. M/s. Chokhawala Distributors – Brass Adaptor.

xxix) Steel Re-inforced Rubber Hose (Type-4)

1. M/s Super Seal Flexible Hose Ltd.
2. M/s Suraksha Products Pvt. Ltd.
3. M/s Vansh Industries
4. M/s T & L Gases

xxx) Corrugated Flexible Metal Hoses (Anaconda)

1. M/s KPC Flex Tubes
2. M/s Vestas Hose Division
3. M/s Alpha Flexi Tubes
4. M/s Chandan Enterprises

NOTE:

- 1) For procuring bought out items from vendors other than those listed above, the same may be acceptable subject to the following: -
 - a) The vendor/ supplier of bought out item(s) is a manufacturer/ supplier of said item(s) for intended services and the sizes being offered is in their regular manufacturing supply range.
 - b) The vendor / supplier should not be in the Holiday list of CLIENT / VCS / other PSU.
 - c) Should have supplied at least one single random length (i.e. 5.5 meters to 6.5 meters) for item assorted pipes / tubes and for other items, which are to be supplied in quantity on number-basis (other than assorted pipes / tubes) minimum 01 (One) number of same or higher in terms of size and rating as required for intended services. The bidder should enclose documentary evidences i.e. PO copies, Inspection Certificate etc. for the above, along with their bids.
- 2) For any other item(s) for which the vendor list is not provided, bidders can supply those item(s) from vendors/ suppliers who have earlier supplied same item(s) for the intended services in earlier projects and the item(s) offered is in their regular manufacturing/ supply range. The bidder is not required to enclose documentary evidences (PO copies, Inspection Certificate etc.) along with their offer, however in case of successful bidder, these documents shall required to be submitted by them within 30 days from date of Placement of Order for approval to CLIENT / VCS.

- 3) The details of vendors indicated in this list are based on the information available with VCS, Contractor shall verify capabilities of each vendor for producing the required quantity with. PMC does not guarantee any responsibility on the performance of the vendor. It is the contractor's responsibility to verify the correct status of vendor and quality control of each parties and also to expedite the material in time.

LIST OF RECOMMENDED VENDER/SUPPLIERS OF MAJOR BOUGHT-OUT TEMS

STRUCTURE

Unless otherwise specifically mentioned in the Schedule of Items, Contractor has to use materials as listed below, of only these brand names/Company's names, which are mentioned in the RECOMMENDED list for structural items thereon.

Sl. No.	Items/Name of Products	Makes/Brands/Manufactures
1	Structural Steel	SAIL / TATA / RINL / IISCO / ESSAR / ISPAT
2	Structural Steel Tubes ISI Marked	TATA / JINDAL / SURYA / SWASTIK
3	Synthetic Enamel Paint 1st Quality only	ICI Paint (Deluxe), Asian Paint (Apcolite), Shalimar Paint (Superlac), Goodlass, Nerolac Paint (Nerolac), Berger Paints

Any materials not fully specified in these specification and which may be offered for use in the works shall be subject to approval of Engineer, without which it shall not be used anywhere in the construction works.

LIST OF SUPPLIERS OF MAJOR BOUGHT-OUT ITEMS

A. ELECTRICAL

i) Air Conditioner

- a. O General.
- b. Daikin.
- c. Hitachi.
- d. LG.
- e. Samsung.
- f. Blue star.
- g. Haier.
- h. Voltas.
- i. Videocon.

ii) Batteries (Lead Acid)

- a. Amco Batteries Ltd.
- b. Exide Industries Ltd.
- c. HBL Power System Ltd.
- d. Amara Raja Batteries Ltd.
- e. Luminous Power Technologies Pvt Ltd.
- f. Su-Kam Power Systems Ltd.
- g. Base Corporation Ltd.
- h. Okaya Power Ltd.
- i. Southern Batteries Pvt Ltd.
- j. True Power International Ltd.
- k. Evolute Solutions Pvt Ltd.
- l. Greenvision Technologies Pvt Ltd.
- m. Artheon Electronics Ltd.

iii) Batteries (Nickel Cadmium)

- a. Amco Batteries Ltd.
- b. HBLPower Systems Ltd.
- c. SAFT.

iv) **Battery Charger/DC-DC Converter**

- a. Amara Raja Power System(P)Ltd.
- b. BCH.
- c. Chhabi Electricals Pvt. Ltd..
- d. Caldyne Automatics Limited.
- e. Dubas.
- f. HBL Nife Power Systems Ltd..
- g. Universal Industries Products.
- h. Universal Instrument Mfg. Co Pvt Ltd.

v) **Cable – Fire Alarm & Communication Cables**

- a. Cords Cable Industries Ltd.
- b. CMI.
- c. Delton cables Ltd.
- d. ELKAY Telelinks.
- e. KEI Industries Ltd.
- f. Reliance Engineers Ltd.

vi) **Cable – HT(XLPE)**

- a. Universal Cable Ltd.
- b. KEI Industries Ltd.
- c. Industrial Cables.
- d. NICCO Corporation Ltd.
- e. Uniflex.
- f. Polycab.
- g. Torrent cables Ltd.

vii) **Cable – LT / MV Power and Control**

- a. Cords Cable Industries Ltd.
- b. 2. Universal Cable Ltd.
- c. KEI Industries Ltd.
- d. Havells.
- e. Delton.
- f. Elkay Telelinks.
- g. Evershine Electricals.
- h. Ecko.

- i. Ravin.
- j. Rallison.
- k. Suyog.
- l. Netco.
- m. Uniflex.
- n. Paramount.
- o. Gloster.
- p. Associated cables Pvt Ltd.
- q. CMI.
- r. Gemscab.
- s. Industrial cables.
- t. NICCO.
- u. Polycab.
- v. Torrent.

viii) **Cable – Gland**

- a. Baliga.
- b. Comet.
- c. Flexpro.
- d. Flameproof.
- e. FCG.
- f. Electro Werke.
- g. Dowels.
- h. CCI.
- i. Sudhir Switchigear
- j. Keyson Techno Equipments,

ix) **Cable – Lugs & Terminal Blocks**

- a. Dowels.
- b. Jainson.
- c. Sharma Electrical
- d. Punitam
- e. Yamuna Powers
- f. Rapid Manufacturer
- g. Varun Controls.

x) **Cable – Tray**

- a. Ercon Composites.
- b. Yamuna Power & Infrastructure Ltd.
- c. MEM
- d. Bharti
- e. Profab.
- f. Ratan.
- g. Slotco.

xi) **Cable Termination and Jointing Kit**

- a. CCI.
- b. Raychem.
- c. M-Seal.

xii) **Ceiling/Exhaust/Pedestal Fans & Circulators**

- a. Bajaj Electricals Ltd.
- b. Crompton Greaves Ltd.
- c. Khaitan Electricals Ltd.
- d. Havell's.

xiii) **Contractors – AC Power**

- a. Andrew Yule.
- b. ABB.
- c. BHEL.
- d. C&S.
- e. Havell's.
- f. L&T.
- g. Schneider.
- h. Siemens Ltd.
- i. Telemecanique.

xiv) **Control Transformer**

- a. AE.
- b. Indushree.
- c. Intra Vidyut.
- d. Kalpa Electricals.

- e. Transpower Industries Ltd.
- f. Siemens.

xv) GAS/DG Set

- a. Sterling and Wilson.
- b. Jackson Limited.
- c. Sudhir Gensets.
- d. Power Engineering (India) Pvt Ltd.
- e. Prasha Technologies Limited.
- f. Kumar Generator house.
- g. Ashok Leyland Ltd.
- h. Powerica Limited.
- i. Supernova Engineers Limited.
- j. Bhaskar Power Products (P) Ltd.
- k. Caterpillar India (P) Ltd.
- l. Cummins India Ltd.
- m. Escorts Ltd.
- n. Greaves Cotton Ltd.
- o. Kirloskar ltd.
- p. Mahindra & Mahindra Ltd.
- q. Honda.
- r. Perkins.
- s. Eicher.
- t. Tata Motors.
- u. Ashok Leyland.

xvi) Earthing Materials

- a. Rukmani Electrical & Components Pvt Ltd.
- b. Indiana Grating Pvt Ltd.
- c. Jef Techno Solutions Pvt Ltd.
- d. Flame proof LDB's/ JB,s/Control Station/ switches
- e. FCG
- f. Sudhir
- g. Prompt Engineering Works
- h. Flame Proof equipments pvt. Ltd.
- i. Baliga Lighting Equipments Pvt. Ltd.

j. Flexpro Electricals Pvt. Ltd.

xvii) Flame proof LDB's/ JB,s/Control Station/ switches

- a. FCG.
- b. Sudhir switchgears.
- c. Prompt Engineering Works
- d. Flame Proof equipments pvt. Ltd.
- e. Baliga Lighting Equipments Pvt. Ltd.
- f. Flexpro Electricals Pvt. Ltd.
- g. Exprotecta, Beroda.
- h. FFLP Control Gears.
- i. Sterling.

xviii) High Mast

- a. Bajaj Electricals Limited.
- b. Crompton Greaves Limited..
- c. Philips India Limited.
- d. Surya Roshani.

xix) High Voltage PCC/ MCC panels

- a. BHEL.
- b. Control and Switchgear.
- c. Siemens.
- d. Tricolite Electrical Industries.
- e. Schneider.
- f. CGL.
- g. L&T.
- h. ABB.

xx) Indicating Lamps

- a. Alstom Ltd.
- b. BCH.
- c. L&T Ltd.
- d. Siemens Ltd.
- e. Vaishno Electricals.
- f. Technik

g. ABB

xxi) **Indicating Meters**

a. ABB.

b. AMCO.

c. AE.

d. Alstom Ltd. (EE).

e. Conzerv/Schneider

f. Elecon Measurement Pvt. Ltd.

g. HPL Electric & Power Pvt. Ltd.

h. MECO Instruments Ltd.

i. Minilec.

j. Rishabh Instruments Pvt. Ltd.

k. Trinity energy system.

l. Kaycee.

m. Salzer.

xxii) **Lighting Fixtures**

a. GE Lighting Pvt. Ltd.

b. Bajaj Electricals Ltd.

c. Crompton Greaves Ltd.

d. Philips India Ltd.

xxiii) **Lighting Fixtures – Flameproof**

a. Bajaj Electricals Ltd.

b. Baliga Lighting Equipment Pvt. Ltd.

c. Crompton Greaves Ltd.

d. CEAG Flameproof Controlgear Pvt. Ltd.

e. Flexpro Electricals Pvt. Ltd.

f. Philips India Ltd.

g. Sudhir Switchgears Pvt. Ltd.

h. FCG.

xxiv) **Miniature Circuit Breakers (MCBs) and Lighting DB**

a. ABB.

b. Hagger.

- c. Havell's India Ltd.
- d. Indo Asian Fusegear Ltd.
- e. Legrand.
- f. MDS Switchgear Ltd.
- g. Schneider.
- h. Siemens Ltd..
- i. HPL.
- j. L & T

xxv) Moulded Case Circuit Breaker (MCCBs)

- a. ABB.
- b. Andrew Yule.
- c. Larsen & Toubro.
- d. Schneider.
- e. Siemens.
- f. Control and Switchgear.
- g. Indo Asian,
- h. Hager.
- i. Merlin Gerin.
- j. Havell's India Ltd

xxvi) Protection Relays – Thermal

- a. BCH.
- b. L&T Ltd.
- c. Siemens Ltd.
- d. Telemenchanique & Controls (India) Ltd.

xxvii) Low/Medium Voltage Power Control Center (PCC)/ MCC/ PDB/ MLDB/ LDB

- a. ABB.
- b. BCH.
- c. BHEL.
- d. C & S.
- e. Elecmech Switchgear & Instrumentation.
- f. KMG ATOZ.
- g. L&T.

- h. Pyrotech Electronics Pvt. Ltd.
- i. Risha control Engineers Pvt. Ltd.
- j. UDKAM PROCESS EQUIPMENT INDIA PVT. LTD
- k. Tricolite Electrical Industries.
- l. Unilec Engineers Ltd.
- m. Vidyut Control India Pvt. Ltd.
- n. Control and Schematic.
- o. Zenith Engineering.
- p. Schneider Electric,
- q. AEG,
- r. HAVELL'S,
- s. MDS.

xxviii) Push Buttons

- a. BCH.
- b. Alstom Ltd.
- c. L&T.
- d. Siemens Ltd.
- e. Telemenchanique & Controls (India) Ltd.
- f. Vaishno Electricals.

xxix) Switches-Control

- a. BCH.
- b. Easum Reyrolle Relays & Devices Ltd.
- c. Alstom.
- d. Kaycee Industries Ltd..
- e. L&T.
- f. Siemens Ltd.

xxx) Switches – 5/15A Piano/ Plate, Switch Socket

- a. Anchor Electronics & Electricals Pvt. Ltd.
- b. Kingal Electricals Pvt. Ltd.
- c. North-West Switchgear Ltd.

xxxi) Switch Socket Outlets (Industrial)

- a. Alstom Ltd.

- b. Best & Crompton Engineering Ltd.
- c. BCH.
- d. Crompton Greaves Ltd.
- e. Essen Engineering Company Pvt. Ltd.

xxxii) Solar Power System Modules

- a. Tata Power Solar Systems Ltd
- b. REIL,
- c. CEIL,.
- d. HBL Power.
- e. Vikram Solar.
- f. Waaree Solar.
- g. Solar Semiconductor.
- h. Sonali.

xxxiii) Solar Street Lighting

- a. Tata BP Solar (I) Ltd.
- b. REIL, Jaipur.
- c. CEIL, Sahibabad.
- d. HBL.

xxxiv) Terminals Blocks

- a. Connectwell.
- b. Controls & Switchgear Co. Ltd.
- c. Elmex Controls Pvt. Ltd.
- d. Essen Engineering Co. Pvt. Ltd.

xxxv) Transformers

- a. ABB.
- b. Andrew Yule.
- c. Areva.
- d. BHEL.
- e. Bharat Bijlee
- f. Crompton Greaves.
- g. EMCO Ltd..
- h. Intra Vidyut.

- i. Indushree.
- j. Indcoil
- k. Kirloskar.
- l. Skippers Electricals.
- m. Transformers & Rectifiers (I) Ltd.
- n. Voltamp.

xxxvi) UPS System and Inverter

- a. DB Power.
- b. Keltron.
- c. Hi-Rel/HITACHI.
- d. Dubas.
- e. Toshiba Corporation.
- f. Fuzi Electric Co Ltd.
- g. Emerson.
- h. Synergy System.
- i. Eaton.

xxxvii) GI-Octagonal Pole

- a. Bajaj.
- b. Transrail.
- c. Wipro.
- d. K.L. Industries.

xxxviii) Electrical Motors

- a. Siemens.
- b. Crompton Greaves.
- c. Kirloskar.
- d. BHEL.
- e. Bharat Bijlee.
- f. Hindustan motors.
- g. Alstom.
- h. Texmo.
- i. GE India.
- j. National Motors.
- k. ABB.

xxxix) List of Recommended Manufacturers for Heater

- a. Escorts Limited, Faridabad, Haryana.
- b. Spherohot / Kanti Lal Chuni Lal & Sons Appliances Pvt Ltd.Surat.
- c. Kerone, Bhayander(E), Thane – 401105.
- d. Excel Heaters, Andheri (West), Mumbai - 400 053, India.
- e. Nirmal Industrial Controls Pvt. Ltd., Mulund(W), Mumbai - 400 080.

xl) Cathodic Protection Agencies/Contractor/ Venders

- a. Raychem-RPG Private Limited.
- b. CALTECH Engineering Service.
- c. Universal Corrosion Prevention India.
- d. Cathodic Technology Limited.
- e. Cathodic Control Company Pvt. Ltd.
- f. CORRTECH International Pvt Ltd.
- g. MITCORR Cathodic Protection Pvt Ltd.
- h. Underground Pipeline & NDTs Pvt. Ltd.
- i. JG Corrosion Solution.
- j. Mercury Cathodic Protection Service.
- k. UNDTs Corrosion Service.

xli) CP CABLES

- a. Brooks Cables.
- b. Nicco Corporation Ltd.
- c. CCI Ltd.
- d. Delton Cables Ltd.
- e. KEI Industries.
- f. Torrent Cables.
- g. Universal cables.
- h. Victor Cables.
- i. Associated Flexible & Wires Pvt Ltd.
- j. Asain Cables (RPG Cables).
- k. Fort Gloster (Gloster Cables Ltd).
- l. Finolex Cable.
- m. Rediant Cables.
- n. NETCO Cables Pvt Ltd.

o. Havells Ltd.

xlii) CP SACRIFICIAL ANODES

- a. M/s Scientific Metals Engineers Pvt. Ltd., Karaikudi
- b. M/s PSL Holding Pvt. Ltd., Mumbai.
- c. M/s Cathodic Controls, Bangalore.
- d. M/s BHEL, Bhopal.
- e. M/s Nippon Corrosion, Japan. or Equivalent.
- f. M/s AFIC, KSA. or Equivalent.
- g. M/s Platt Bros. and Company, USA or Equivalent.
- h. M/s Wilson Walton International. or Equivalent.
- i. M/s Impalloy International. or Equivalent.
- j. M/s Corrpro International. or Equivalent.
- k. M/s HOCKWAY, UK. or Equivalent.
- l. M/s NAKABOHITEC, Japan . or Equivalent.
- m. Cortech International
- n. Titanor Component

xliii) CP Portable Reference Cell

- a. M/s MC Miller (USA) or Equivalent.
- b. Borin, USA or Equivalent
- c. Krick or Equivalent
- d. M/s corrtech. or Equivalent

xliv) CP Permanent Reference Cell

- a. M/s Borin Manufacturer USA, or Equivalent.
- b. M/s MC Miller USA, or Equivalent.
- c. M/s corrtech. or Equivalent.
- d. Krick or Equivalent

xlv) CPTR (AC operated)

- a. M/s Canara Electric. or Equivalent.
- b. (M/s Raychem RPG Ltd). or Equivalent.
- c. M/s Automatic Transformer Kriston systems Rectifier Unit/DC operated Automatic CPPSM Unit. or Equivalent.

xlvi) CP Thermit Weld

- a. M/s Erico, USA/Europ, or Equivalent.

- b. M/s Cad Weld Pin Brazing. or Equivalent.
- c. M/s Safe Track, M/s BAC UK. or Equivalent.

xlvii) CP Surge diverter/Spark gap arrestor (Ex-d)

- a. M/s Dhen, M/s OBO, or Equivalent.
- b. M/s Corrpro system, or Equivalent.
- c. M/s Sohne. or Equivalent.

xlviii) Digital Multimeter

- a. MOTWANE,
- b. Rishabh,
- c. Fluke or Equivalent.

xlix) CTSU

- a. M/s Kriston systems or Equivalent.

l) CP Solid state polarisation cell.

- a. M/s Dairyland, or Equivalent.
- b. M/s Corrpro systems. or Equivalent.
- c. Mc Miller
- d. Krik Engineering

li) Petroleum Coke Breeze:

- a. M/s Goa Carbon , Goa
- b. M/s India carbon, Durgapur(WB)

lii) Pin brazing:

- a. BAC
- b. Safetrack

liii) CP Anode (MMO Type):

- a. M/s corrtech
- b. Scientific Metal Engineers Karaikudi
- c. Titanor Component Ltd., Goa, India.
- d. Denora Permelic S.P.A (Italy). or Equivalent.
- e. Oronzio De Nora S.A. Ingano Switzerland. or Equivalent.
- f. CER Anode Technologies International USA. or Equivalent.
- g. ACTEL, UK. or Equivalent.

- h. ELTECH System Corporation, Texas. or Equivalent.
- i. MAGNETO-CHEMIE, Netherlands. or Equivalent.
- j. M/S MATCOR (USA). or Equivalent.

liv) Backup Agency for doing CP Survey

- a. PLE Germany, or Equivalent.
- b. Vendor Velde, or Equivalent.
- c. Nippon Japan, or Equivalent.
- d. SSS India CIPL / interference survey.
- e. Balslev Denmark, or Equivalent.
- f. SSS Germany. or Equivalent.

lv) CP Anode Backfill Material :

- a. M/S Goa Carbon (Goa).
- b. M/S India Carbon (Calcutta),
- c. M/S Petrocarbon & Chemical Company (Haldia).

lvi) Heat Shrink Cap For CP Anode

- a. M/s RAYCHEM, or Equivalent.
- b. M/s MATCOR (USA) To Cable Joint. or Equivalent.

lvii) ER- PROBE (External Corrosion

- a. M/s Rose Corrosion Services UK, or Equivalent.
- b. M/s Metal Samples, USA. or Equivalent.
- c. M/s Monitoring) Roharbak Cosasco USA. or Equivalent.
- d. M/s Caproco UK . or Equivalent.

lviii) ER- PROBE & Corrosion Coupon

- a. M/s Rose Corrosion Services UK, or Equivalent.
- b. M/s Metal Samples, or Equivalent.
- c. USA Assembly. or Equivalent.
- d. M/s Roharbak Cosasco, USA. or Equivalent.
- e. M/s Caproco, UK. or Equivalent.

Note-For any other brought out item(s) for which the vendor list is not provided in the tender , bidders can supply those item(s) from vendors/ suppliers who have earlier supplied similar item(s) for the intended services in earlier Oil and Gas projects and the item(s) offered is in their regular manufacturing/ supply range.

- 1) The vendor/supplier should not be in the Holiday list of OWNER/ ONSULTANT/other PSU
- 2) The bidder is not required to enclose documentary evidences (PO copies, Inspection & Completion with satisfactory working certificates etc.) along with their offer, however in

case of successful bidder, these documents shall required to be submitted by them within 30 days from date of Placement of Order for approval to OWNER / CONSULTANT.

LIST OF RECOMMENDED VENDER/SUPPLIERS OF MAJOR BOUGHT-OUT ITEMS

INSTRUMENTATION

1. PRESSURE GAUGES

- AN Instruments Pvt Ltd
- Badotherm Process Instruments B.V.
- Baumer Bourdon Haenni S.A.S
- British Rototherm Co Ltd
- Budenberg Gauge Co Ltd
- Dresser Inc
- Forbes Marshall (Hyd) Pvt Ltd
- General Instrument Consortium
- H. Guru Instruments (South India) Pvt Ltd
- Manometer (India) Pvt Ltd
- Nagano Keiki Seisakusho Ltd
- Hirlekar Precision, India
- Waaree Instruments Ltd
- Walchandnagar Industries Ltd (Tiwac Divn)
- Wika Alexander Wiegand & Co GmbH
- Wika Instruments India Pvt Ltd
- Ashcroft India Pvt Ltd.

2. TEMPERATURE GAUGES

- AN Instruments Pvt Ltd.
- Badotherm Process Instruments B.V.
- Bourdon Haenni S.A.

- Dresser Inc.
- General Instruments Consortium
- H. Guru Instruments (South India) Pvt Ltd
- Nagano Keiki Seisakusho Ltd
- Solartron ISA
- Walchandnagar Industries Ltd (Tiwac Divn)
- Wika Alexander Wiegand & Co GmbH
- Wika Instruments India Pvt Ltd
- Pyro Electric, Goa
- Ashcroft India Pvt Ltd.

3. **TEMPERATURE ELEMENTS, THERMO-WELLS**

- ABB Automation Ltd
- Altop Industries Ltd
- Bourdon Haenni S.A.
- Detriv Instrumentation & Electronics Ltd
- General Instruments Consortium
- Japan Thermowell Co Ltd
- Tecnomatic S.P.A
- Tempsen Instrument India Ltd
- Thermo Electric Co. Inc.
- Thermo-Couple Products Co
- Thermo-Electra B.V.
- Wika Alexander Wiegand & Co GmbH
- Altop Industries Ltd., Baroda
- Nagman Sensors (Pvt.) Ltd.
- Pyro Electric, Goa

4. POSITIVE DISPLACEMENT FLOW METERS

- RMG (Germany)
- Elster Instromet
- Romet
- Dresser
- Itron
- FMG
- Common
- Metreg
- Raychem RPG
- Vemmtec

5. TURBINE FLOW METER

- Daniel
- Elster Instromet
- Itron
- RMG
- Rockwin

6. ELECTRONIC VOLUME CORRECTOR

- Elgas
- Itron
- Plum
- Pietro Fiorentini

7. ORIFICES (METER RUN, FLOW CONDITIONER, ORIFICE PLATE AND ASSEMBLY)

- Emerson
- FMC, USA
- Pietro Fiorentini S.P.A (Italy)
- Canalta Controls, Canada

8. FIELD INSTRUMENTS (P, DP, F, L, T)

- ABB Ltd
- Honeywell
- Fuji Electric Instruments Co Ltd
- Yokogawa
- Invensys India Pvt.Ltd

9. PRESSURE REGULATOR AND SLAM SHUT VALVE

- Pietro Fiorentini S.P.A. (Italy)
- Emerson
- RMG-Regel Messtechnik (Germany)
- Mokveld Valves BV (Netherlands)
- Schlumberger (USA)
- Gorter Controls B V (Netherlands)
- Instromet International NV
- Nirmal Industrial Controls Pvt Ltd. (up to 6" size only)
- ESME Valves Ltd
- Kaye & Macdonald Inc.
- Nuovo Pignone S.P.A (Italy) (GE Oil Co.)
- Richards Industries (Formerly Treloar)
- Samson AG Mess-und Regeltechnik
- Tormene Gas Technology
- Dresser Inc, USA (upto 8" size, 300# class only)

10. PRESSURE SAFETY VALVES

- Keystone Valves (India) Pvt. Ltd.
- Larson & Toubro Ltd.
- Lesser GmbH & Co KG
- Mekaster Engg Ltd..
- Tyco Sanmar Ltd. (New Delhi)
- Anderson Greenwood Crosby
- BHEL (Trichy)
- Curtiss Wright Flow Control Corporation
- Dresser Inc.
- Fukui Seisakusho Co. Ltd

- Nakakita Seisakusho Co Ltd
- Nuovo Pignone S.P.A (Italy) (GE Oil co)
- Parcol S.P.A
- Safety Systems UK Ltd
- Tai Milano S.P.A
- Weir Valves & Controls France
- Bliss Anand Pvt Ltd.

11. CONTROL PANEL & ACCESSORIES

- Keltron Controls Ltd., Kerala
- Elechmec Corporation Ltd., Mumbai
- Industrial Controls & Appliances Pvt. Ltd.,
- Alstom System Ltd., Noida
- Emerson Process Management (I) Pvt. Ltd.
- ABB Instruments Ltd., New Delhi
- Larsen & Toubro Ltd.
- Control & Automation, New Delhi
- GE Fanuc Systems Pvt. Ltd., New Delhi
- Rockwell Automation (I) Ltd., Ghaziabad
- Honeywell Automation Ltd.
- Rittal
- Pyrotech Elcronics Pvt Ltd.
- Positronics Pvt Ltd.
- Electronics Corporation of India Ltd.

12. JUNCTION BOXES AND CABLES GLANDS

- Ex-Protecta
- Flameproof Control Gears

- Baliga
- Flexpro Electricals

13. CONTROL AND SIGNAL CABLES

- Associated Cables
- Brook
- Associated Flexibles & Wires (Pvt) Ltd
- Universal Cables Ltd,India
- Delton Cables Ltd, India
- KEI Industries Ltd INDIA
- CMI Limited
- Cords Cable Industries Ltd, India
- Elkay Telelinks (P) Ltd., India
- Udey Pyrocables Pvt Ltd, India
- Goyolene Fibres (I) Pvt Ltd, India
- Netco Cable Industries Pvt Ltd, India
- Nicco Corporation Ltd, India
- Paramount Communications Ltd, India
- Polycab Wires Pvt Ltd, India
- Radiant Cables Pvt Ltd, India
- Reliance Engineers Ltd., India
- Suyog Electricals Ltd, India
- Thermo Cables Ltd

14. SS FITTINGS, INSTRUMENT VALVES & MANIFOLDS

a) For CNG work:

1. Swagelok Co.
2. Parker
3. DK-LOK

b) Except CNG work:

1. Swagelok Co.
2. Parker
3. Aura INC.
4. HOKE
5. Excelsior Engineering works
6. Swastik Engineering works India
7. Comfit and valves pvt ltd
8. Arya craft and engineering pvt ltd
9. DK lok

15. SS TUBES

a) For CNG work:

1. Swagelok Co.
2. Parker
3. Sandvik
4. Ratnamani Metals and Tubes
5. Tubacex

a) Except CNG work:

1. Swagelok Co.
2. Parker
3. Sandvik
4. Heavy metal and tube limited
5. Nuclear fuel complex India
6. Scorodite
7. Ratnamani Metals and Tubes
8. Jindal Saw

LIST OF RECOMMENDED VENDER/SUPPLIERS OF MAJOR BOUGHT-OUT ITEMS

SHOP & FIELD PAINTING

Indian Vendors

- 1.0 Asian Paints (I) Ltd.
- 2.0 Berger Paints Ltd.
- 3.0 Goodlass Nerlolac Paints Ltd.
- 4.0 Jenson And Nicholson Paint Ltd & chokuGu Jenson & Nicholson Ltd.
- 5.0 Shalimar Paints Ltd.
- 6.0 Sigma Coating, Mumabai
- 7.0 CDC Carboline Ltd.
- 8.0 Premier Products Ltd.
- 9.0 Coromandel Paints & Chemicals Ltd.
- 10.0 Anupam Enterprises
- 11.0 Grand Polycoats
- 12.0 Bombay Paints Ltd.
- 13.0 Vanaprabha Esters & Glycer, Mumbai
- 14.0 Sunil Paints and Varnishes Pvt. Ltd.
- 15.0 Courtaulds Coating & Sealants India (Pvt.) Ltd.
- 16.0 Mark-chem Incorporated, Mumbai (for phosphating chemicals only)
- 17.0 VCM Polyurethane Paint (for polyurethane Paint only)

Foreign Vendors For Overseas Products

- 1.0 Sigma Coating, Singapore
- 2.0 Ameron, USA
- 3.0 Kansai Paint, Japan
- 4.0 Hempel Paint, USA
- 5.0 Valspar Corporation, USA
- 6.0 Courtaulds Coating, UK.

Notes:

1. Bidder can select equipment of two different makes, selected from this VENDOR LIST and mention the same in the checklist for technical evaluation attached with the tender. The offered bid must include filled datasheet indicating make, model, size, rating of offered instrument/ equipment duly supported by sizing calculation of offered equipment (wherever applicable).
2. Vendors who have already supplied above equipment in other terminals of client, shall also be considered qualified for this tender provided the supplied equipment are commissioned and running successfully and they have not been put on holiday.
3. Equipment / Instruments of any make which is offered by one bidder and acceptable to client shall be accepted for other bidder also. After placement of order, on request of the successful bidder list of other qualified makes for a particular item (for which successful bidder wants to change the vendor) shall be provided.

4. Bidder shall take prior approval of the make / model no of the offered item and it shall be from the list given above. However additional vendors will be considered in exceptional cases, provided they have supplied for similar application to reputed gas transmission/distribution companies, in quantities at least half the numbers being supplied for this tender, and working satisfactorily for minimum 6 months. Documentary evidence substantiating above shall be submitted for taking approval.

Note:

Above mentioned vendor list is tentative and further addition/deletion may be done as per discretion of Owner.

NOTES:-
 1. ALL DIMENSIONS ARE IN MM UNLESS NOTED OTHERWISE.
 2. FOLLOW WRITTEN DIMENSIONS ONLY. DO NOT SCALE THE DRAWING.

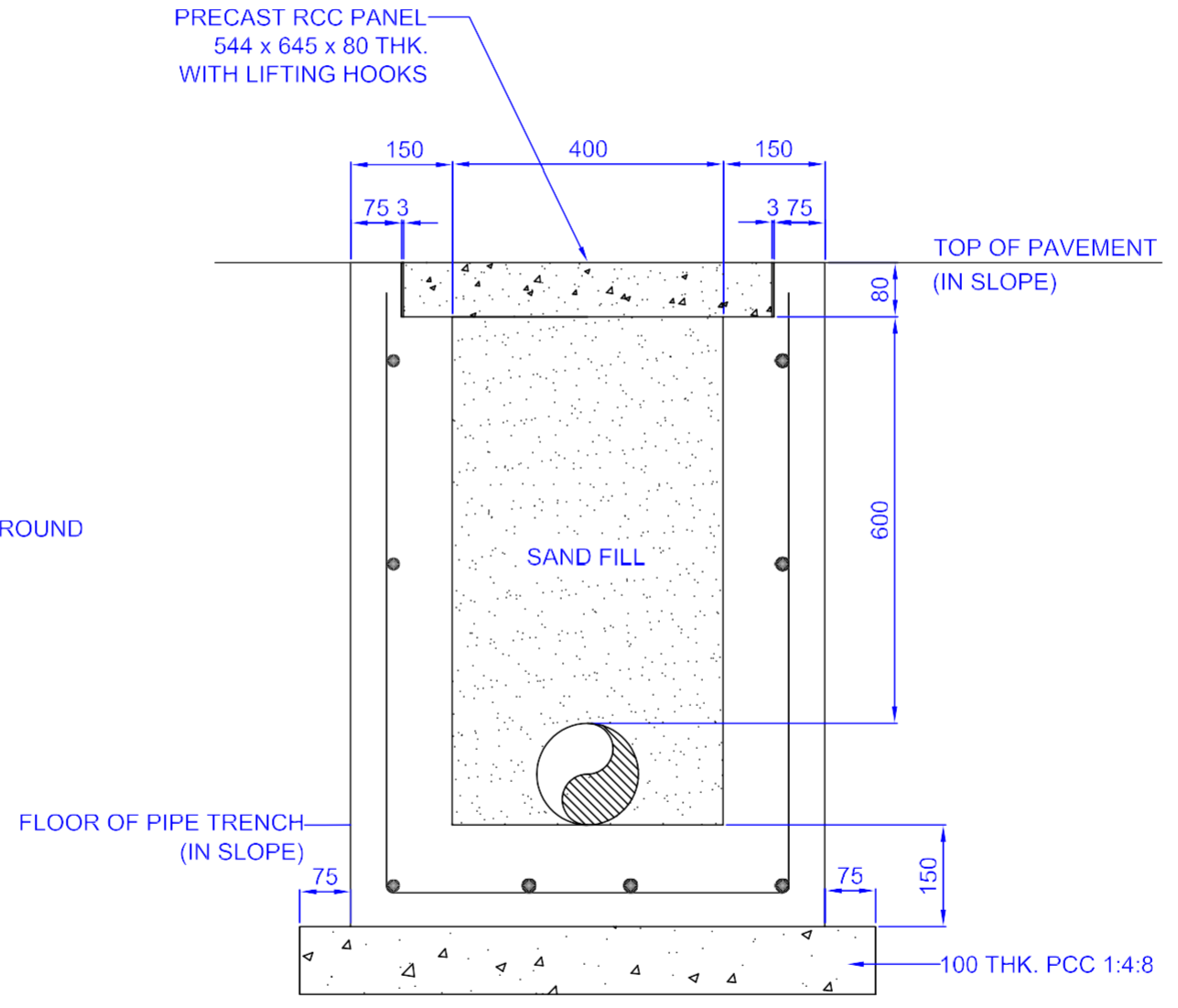
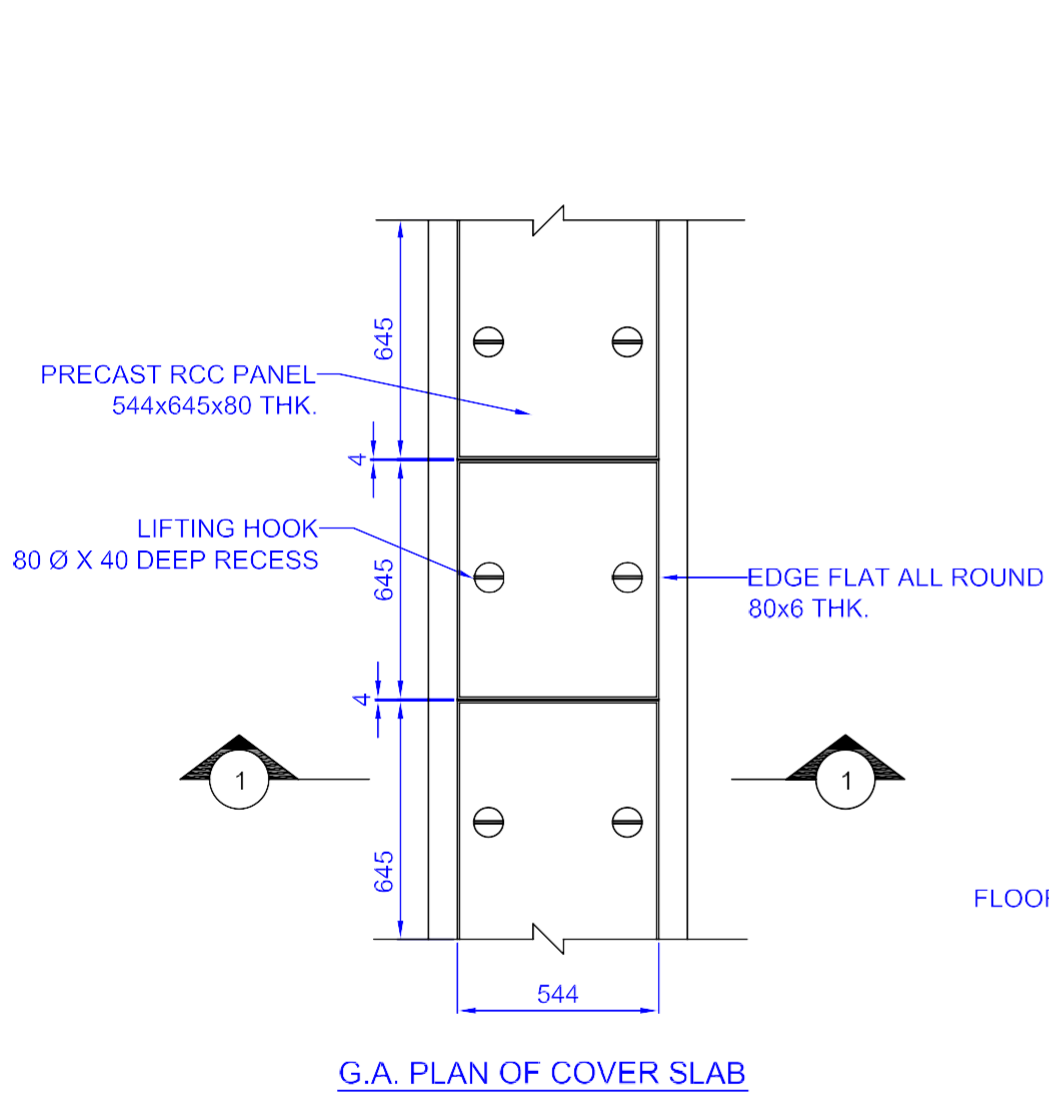

OWNER:				
PMC: M/s. VCS QUALITY SERVICES PVT. LTD.				
PROJECT:				
TITLE: DETAILS OF PIPE TRENCH				
SCALE: 1:20	DATE:	CAD FILE: DATE:	CAD	A3
DRG. NO. -10-03-16 REV-0				

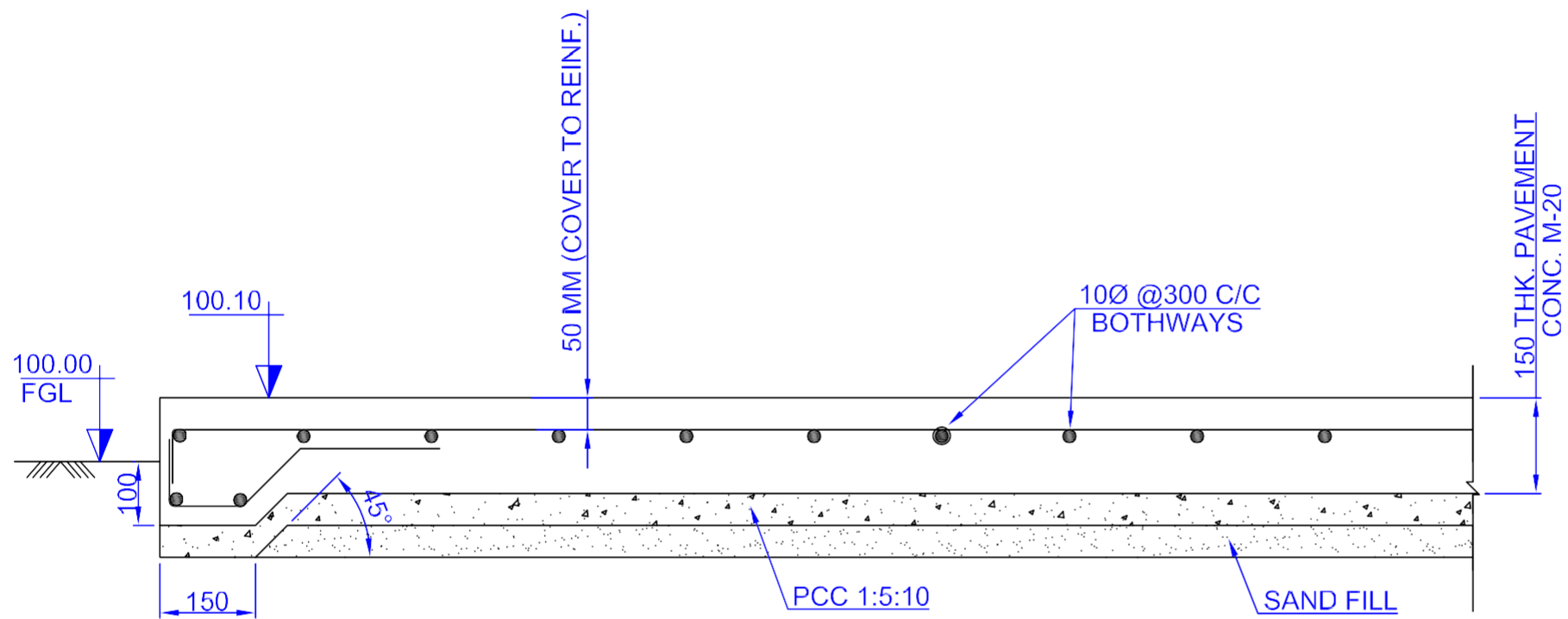

RCC PAVEMENT DETAIL

NOTES:-

1. ALL DIMENSIONS ARE IN MM UNLESS NOTED OTHERWISE.
2. FOLLOW WRITTEN DIMENSIONS ONLY. DO NOT SCALE THE DRAWING.

OWNER:



PMC:



M/s. VCS QUALITY SERVICES PVT. LTD.

PROJECT:

TITLE: STANDARD DETAIL OF RCC PAVEMENT

SCALE	DATE	CAD FILE	DATE	CAD	A3
1:10					

DRG. NO. 10-03-17 REV-0

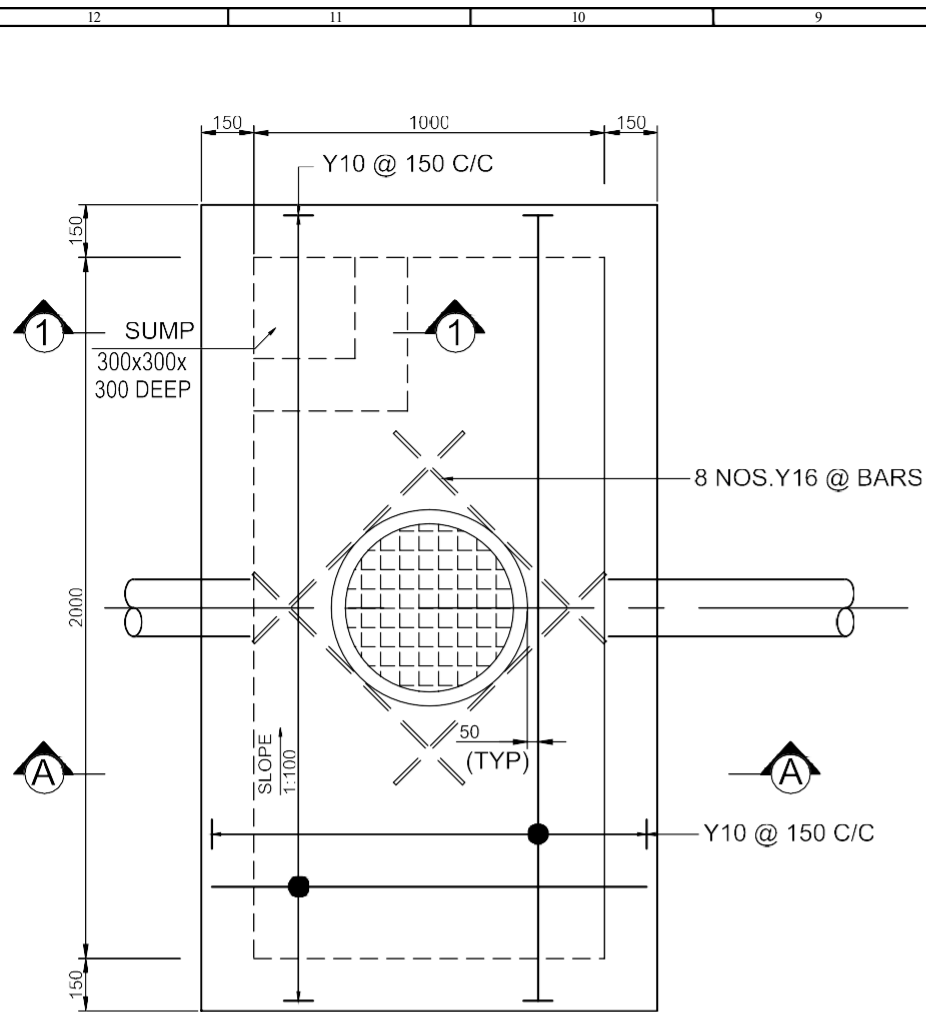

VALVE PIT PLAN
(SCALE 1:20)

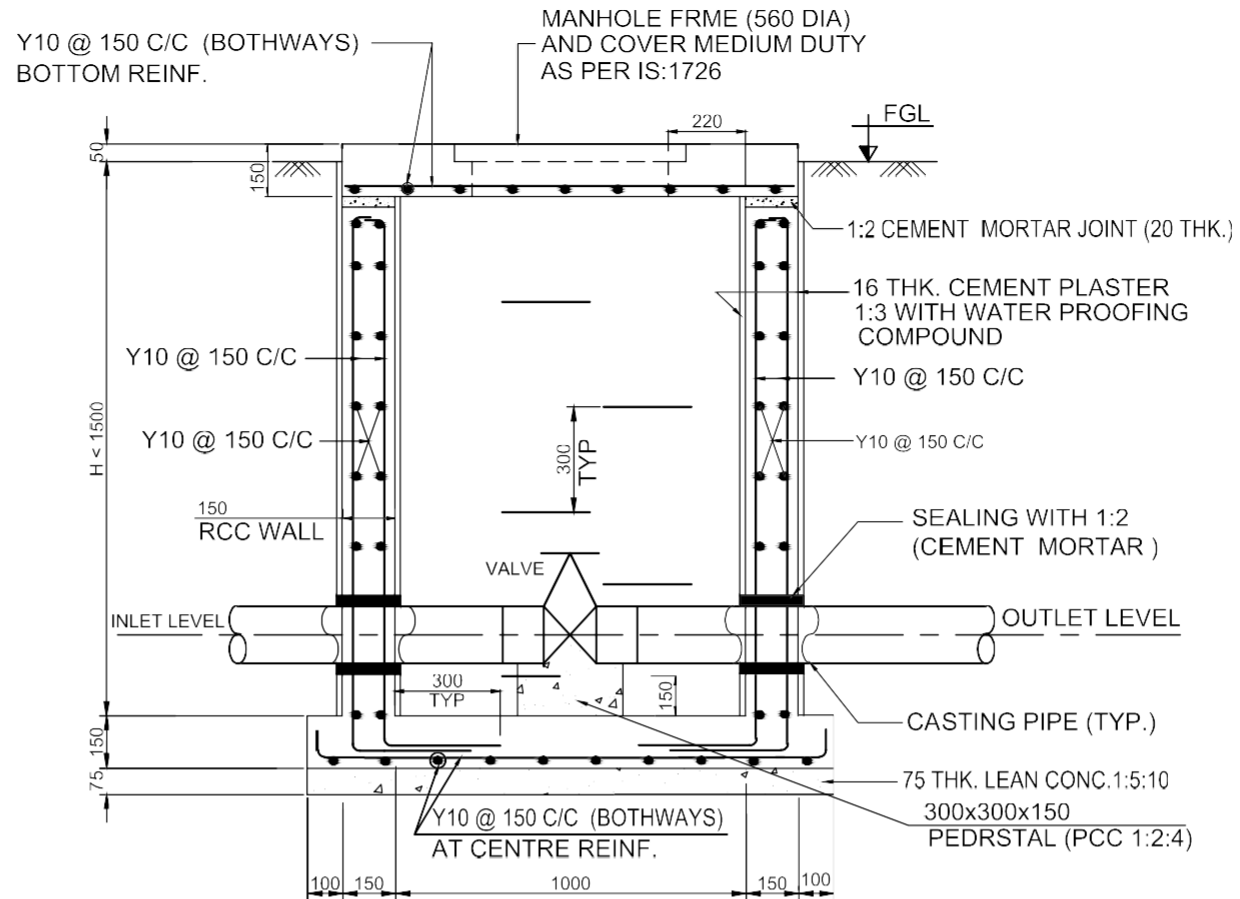

SECTION A-A
(SCALE 1:20)

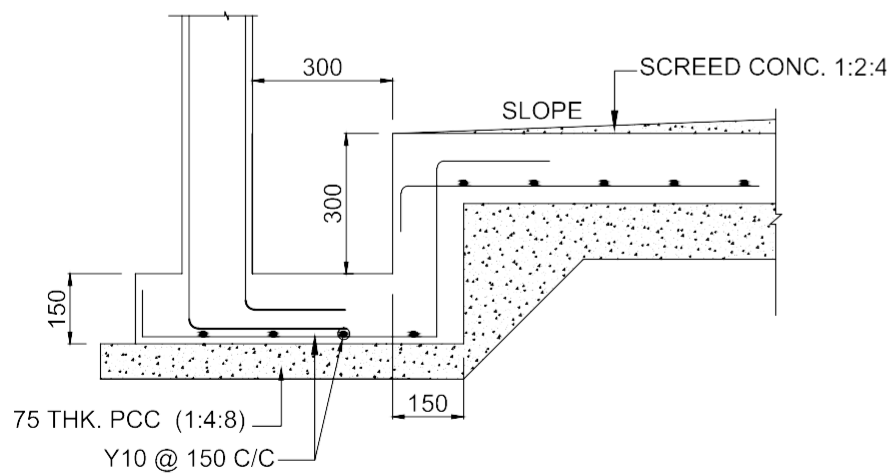

SECTION 1-1
(SCALE 1:15)

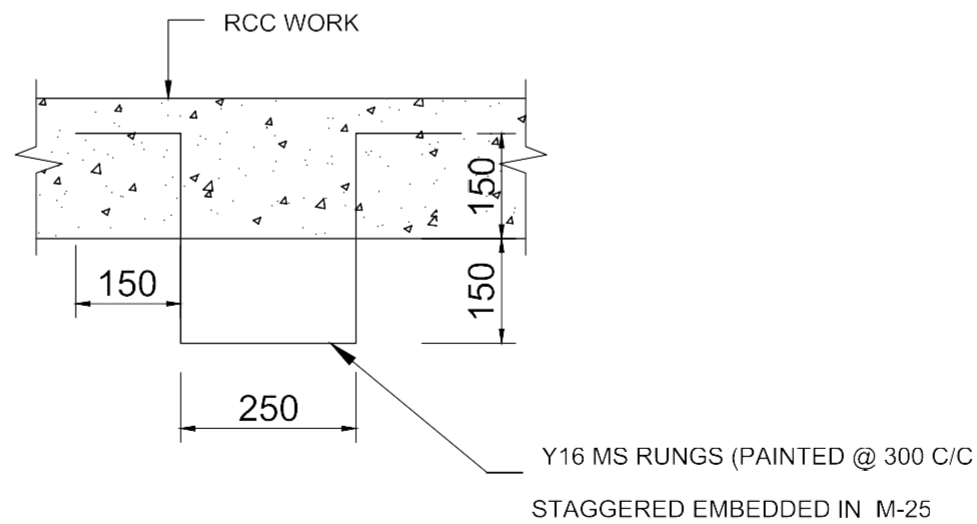

TYPICAL DETAILS OF MS RUNGS
(SCALE 1:10)

NOTES:-

1. ALL DIMENSIONS ARE IN MM UNLESS NOTED OTHERWISE.
2. FOLLOW WRITTEN DIMENSIONS ONLY. DO NOT SCALE THE DRAWING.
3. CLEAR COVER TO MAIN REINFORCEMENT SHALL BE (a) SLAB 20mm
4. GRADE OF CONCRETE USED SHALL BE M-25 CONFORMING.
5. REINFORCEMENT SHALL BE HYSD BARS OF (GRADE Fe 415) CONFORMING TO IS:1786.

OWNER:	HPOIL GAS PRIVATE LIMITED.			
PMC:	M/s. VCS QUALITY SERVICES PVT. LTD.			
PROJECT:	LMC & DMA SERVICES AT AMBALA-KURUKSHETRA GA			
TITLE:	STANDARD DETAIL OF RCC VALVE CHAMBER (TYPE-1)			
SCALE	DATE	CAD FILE	CAD	A3
AS SHOWN	01-07-2014	DATE		

NOTES:-

I

I

H

H

G

G

F

F

E

E

D

D

C

C

B

B

A

A

OWNER: **HPOIL GAS PRIVATE LIMITED.**



PROJECT: **LMC & DMA SERVICES AT
AMBALA-KURUKSHETRA GA**

TITLE: **STANDARD DETAIL OF RCC
VALVE CHAMBER (TYPE-2)**

SCALE: AS SHOWN DATE: 01.07.14 CAD FILE: CAD A3

DRG No. 1007-20-03-21 REV-0

1. ALL DIMENSIONS ARE IN MM UNLESS NOTED OTHERWISE.
2. FOLLOW WRITTEN DIMENSIONS ONLY. DO NOT SCALE THE DRAWING
3. CLEAR COVER TO MAIN REINFORCEMENT SHALL BE (a) SLAB 20mm
4. GRADE OF CONCRETE USED SHALL BE M-25 CONFORMING.
5. REINFORCEMENT SHALL BE HYSD BARS OF (GRADE Fe 415) CONFORMING TO IS:1786.

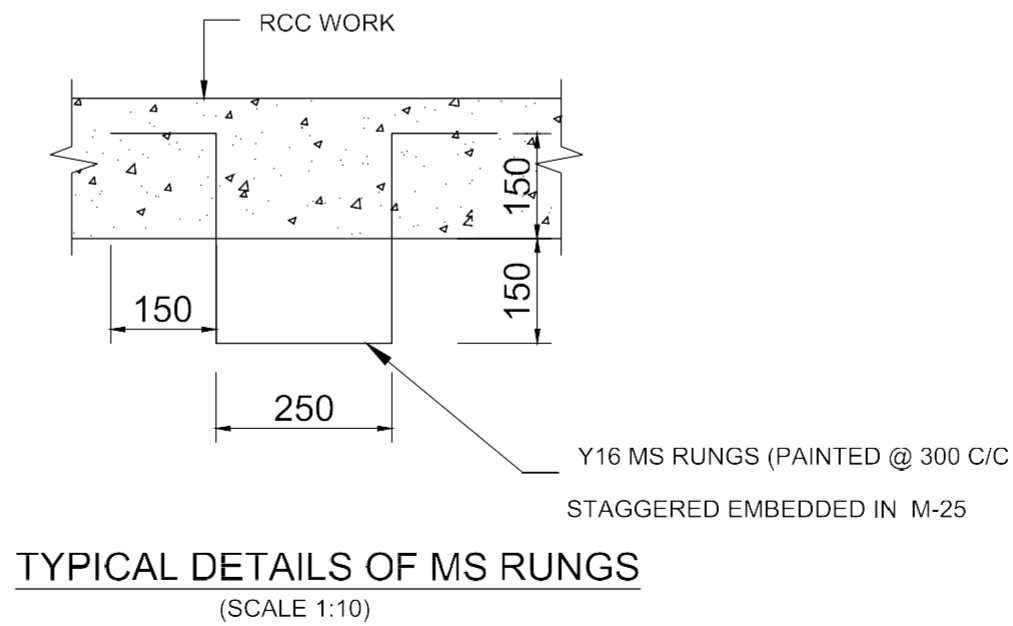
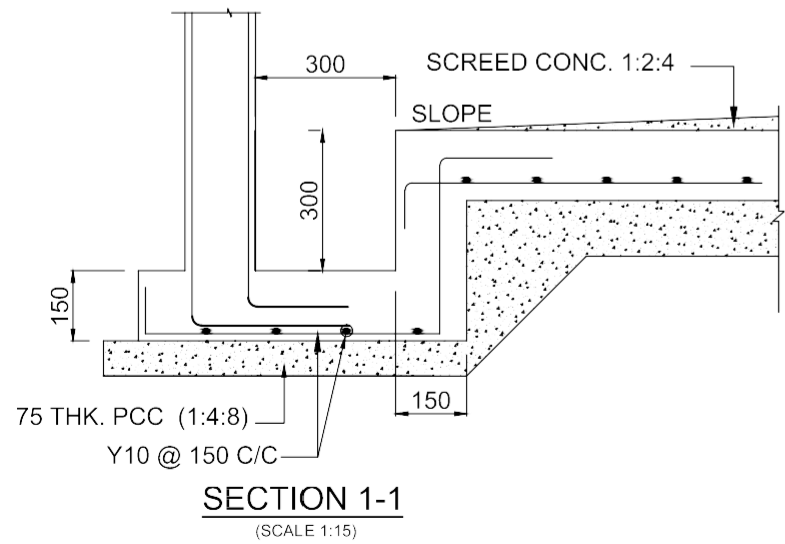
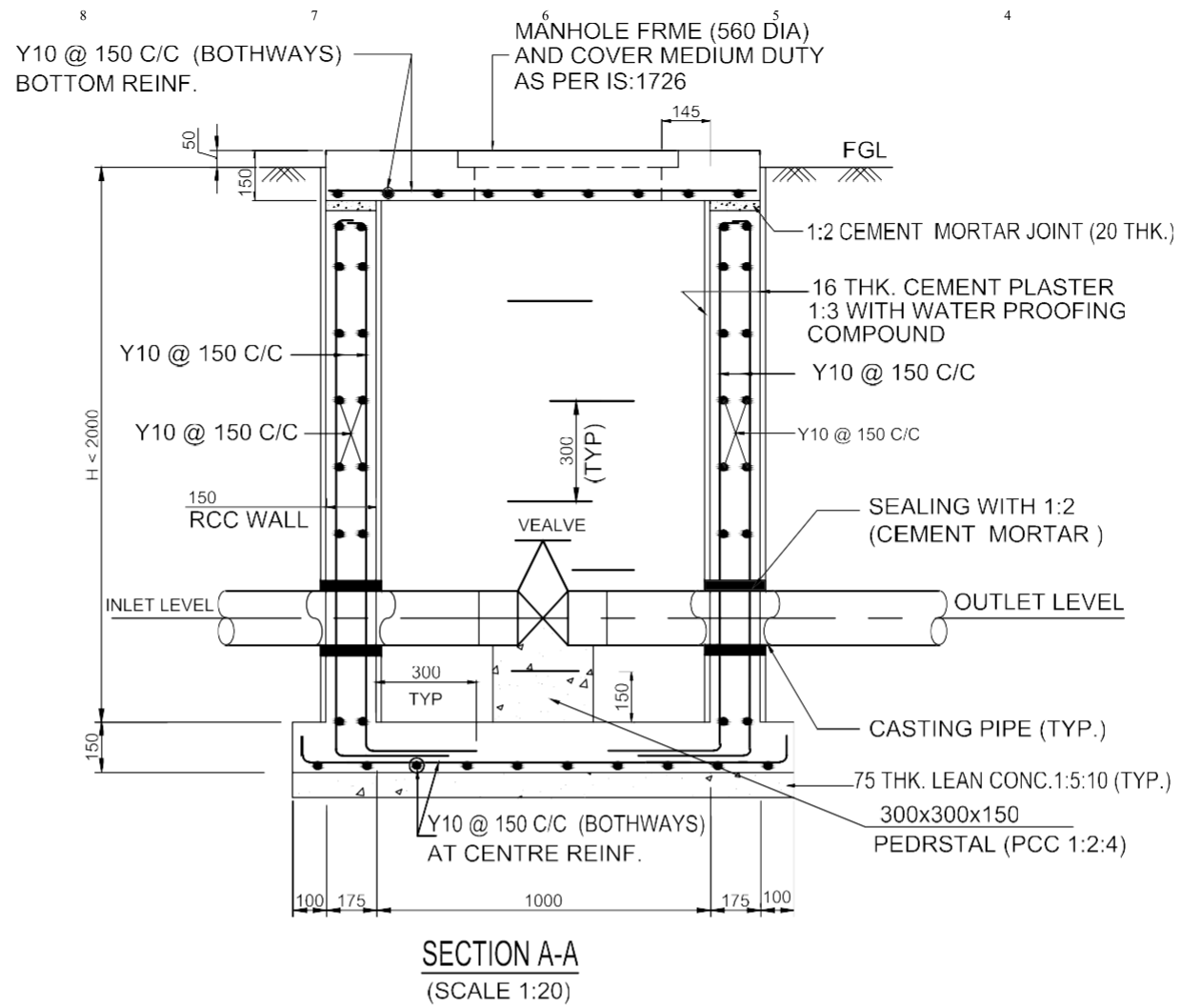
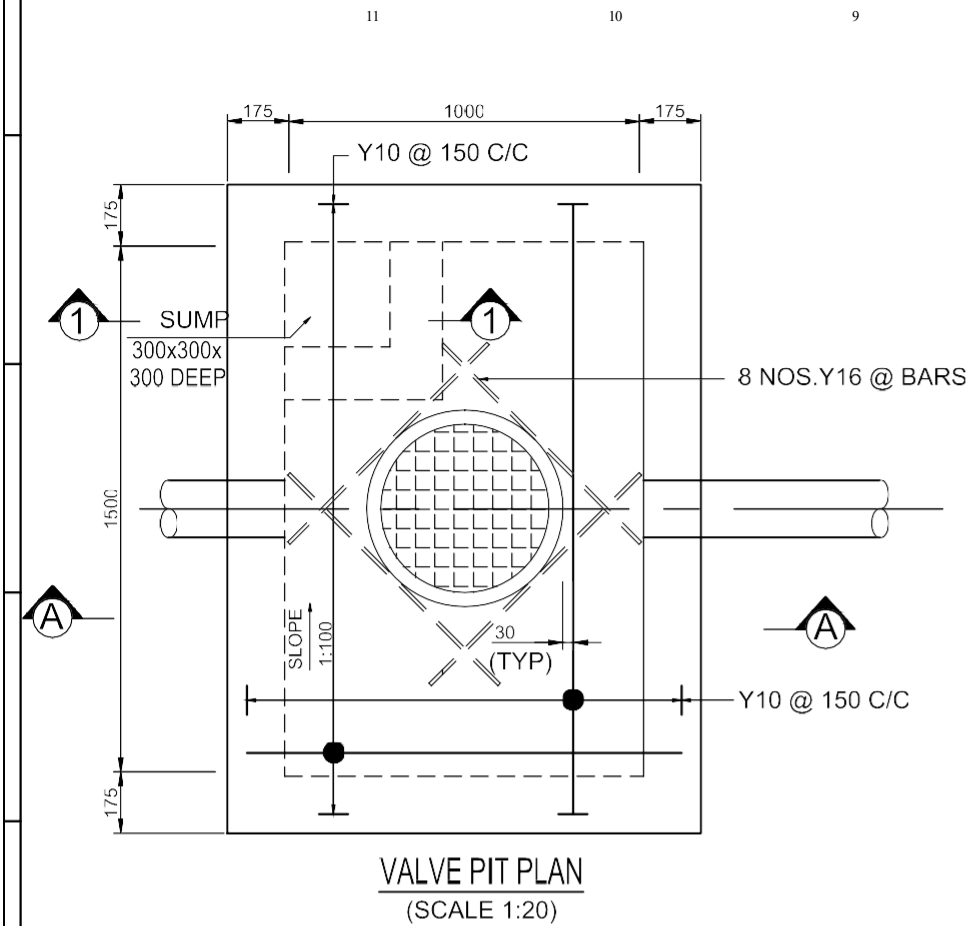

M/s. VCS QUALITY SERVICES PVT. LTD.

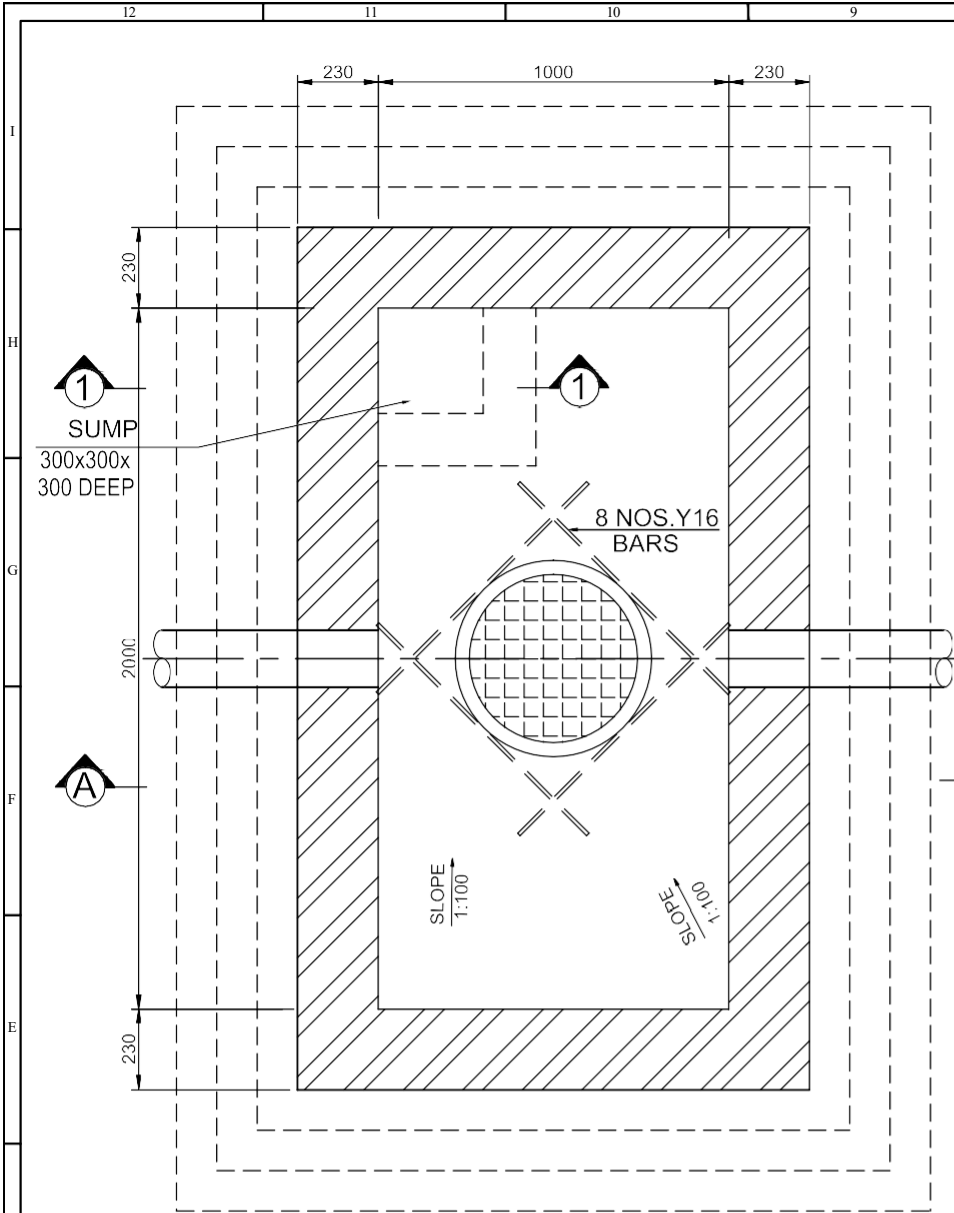

VALVE PIT PLAN
(SCALE 1:20)

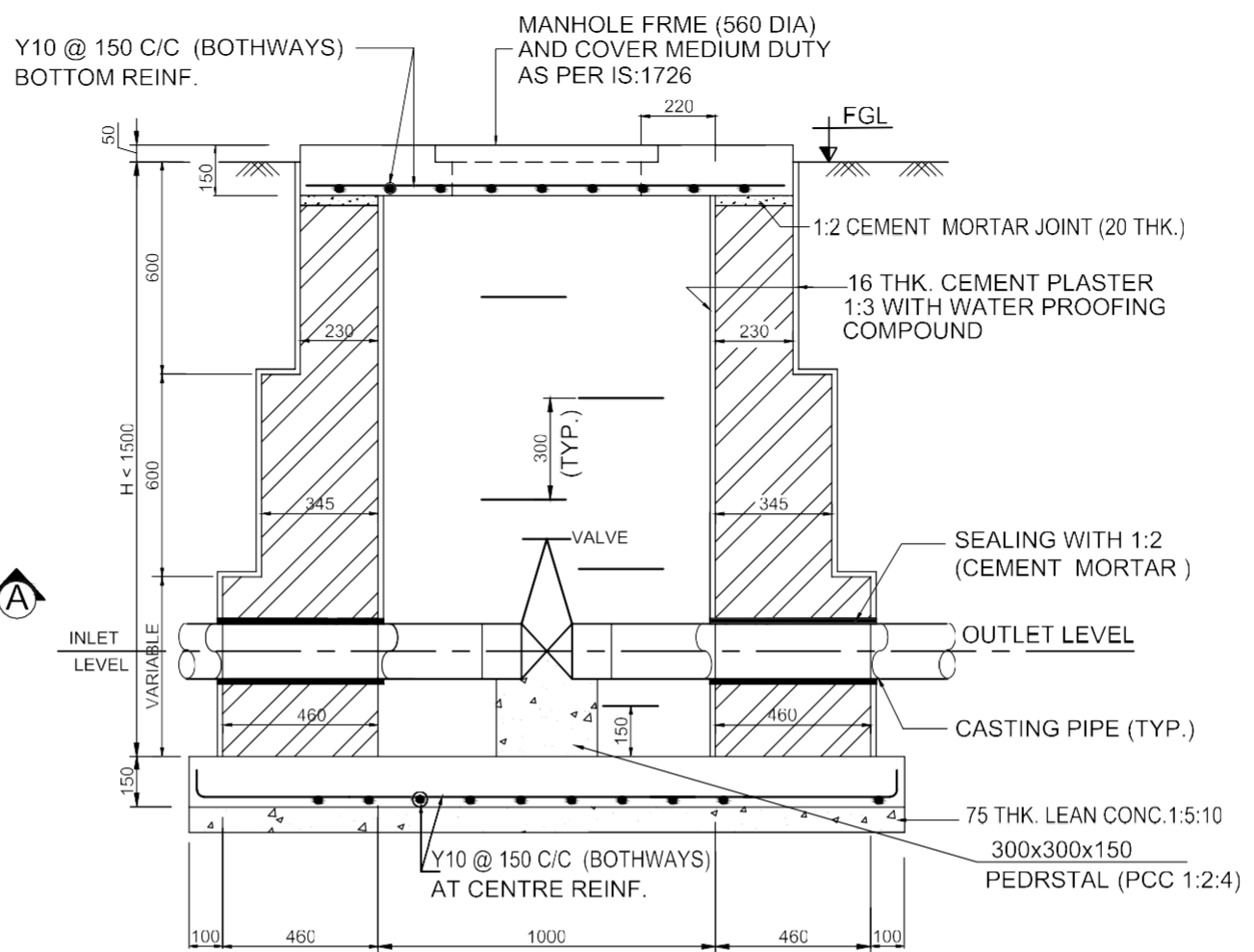

SECTION A-A
(SCALE 1:20)

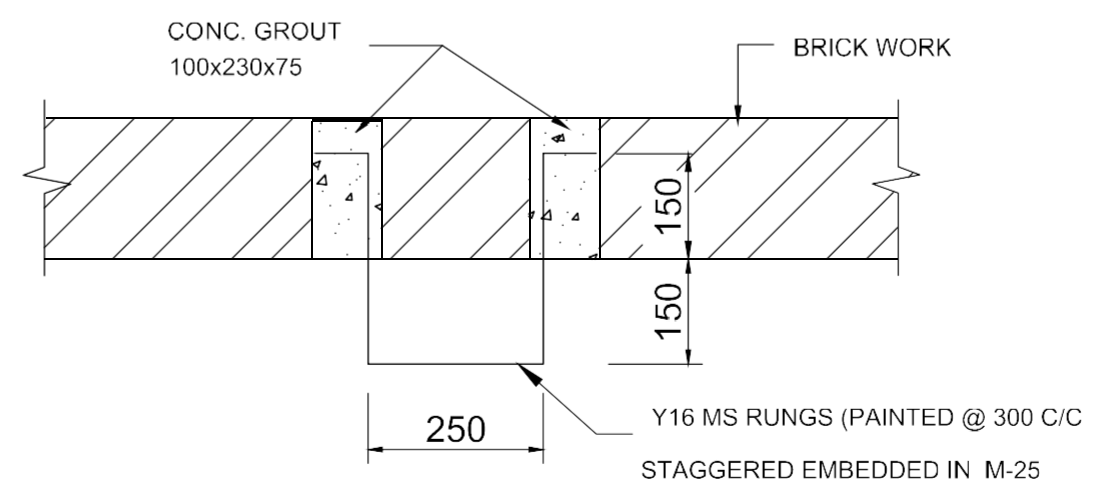

TYPICAL DETAILS OF MS RUNGS
(SCALE 1:10)

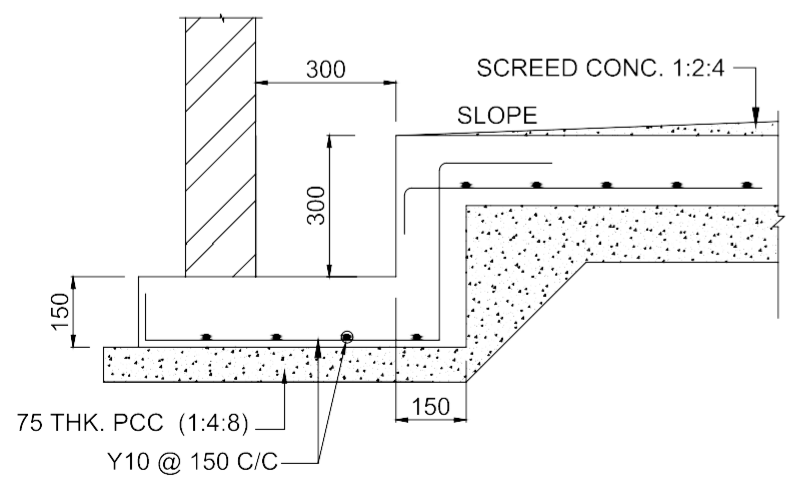

SECTION 1-1
(SCALE 1:15)

- NOTES:-**
1. ALL DIMENSIONS ARE IN MM UNLESS NOTED OTHERWISE.
 2. FOLLOW WRITTEN DIMENSIONS ONLY. DO NOT SCALE THE DRAWING
 3. CLEAR COVER TO MAIN REINFORCEMENT SHALL BE (a) SLAB 20mm
 4. GRADE OF CONCRETE USED SHALL BE M-25 CONFORMING.
 5. REINFORCEMENT SHALL BE HYSD BARS OF (GRADE Fe 415) CONFORMING TO IS:1786.

OWNER: **HPOIL GAS PRIVATE LIMITED.**

PMC: **M/s. VCS QUALITY SERVICES PVT. LTD.**

PROJECT: **LMC & DMA SERVICES AT AMBALA-KURUKSHETRA GA**

TITLE: **STANDARD DETAIL OF BRICK VALVE CHAMBER (TYPE-1)**

SCALE AS SHOWN	DATE 01-07-2014	CAD FILE DATE	CAD	A3
----------------	-----------------	---------------	-----	----

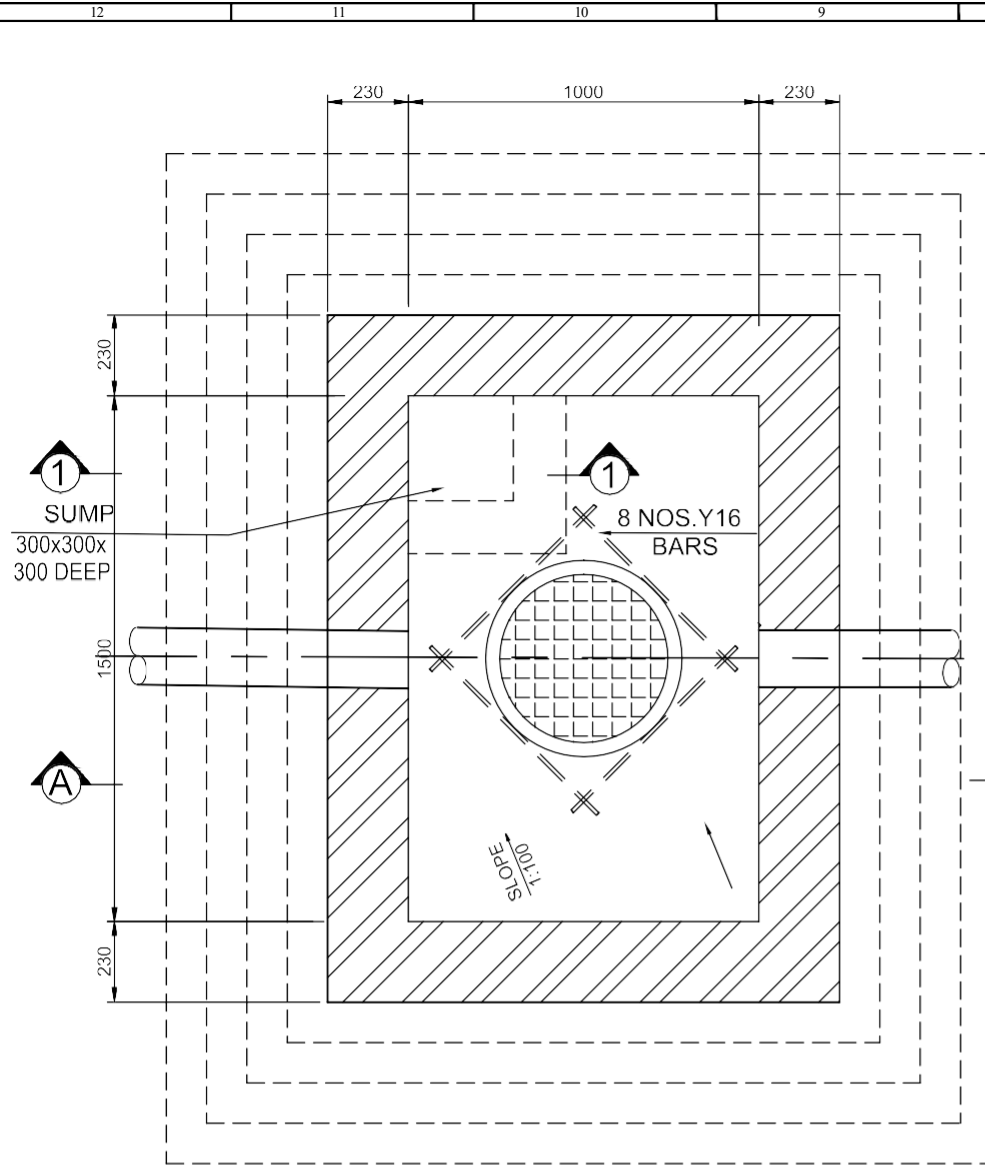

VALVE PIT PLAN
(SCALE 1:20)

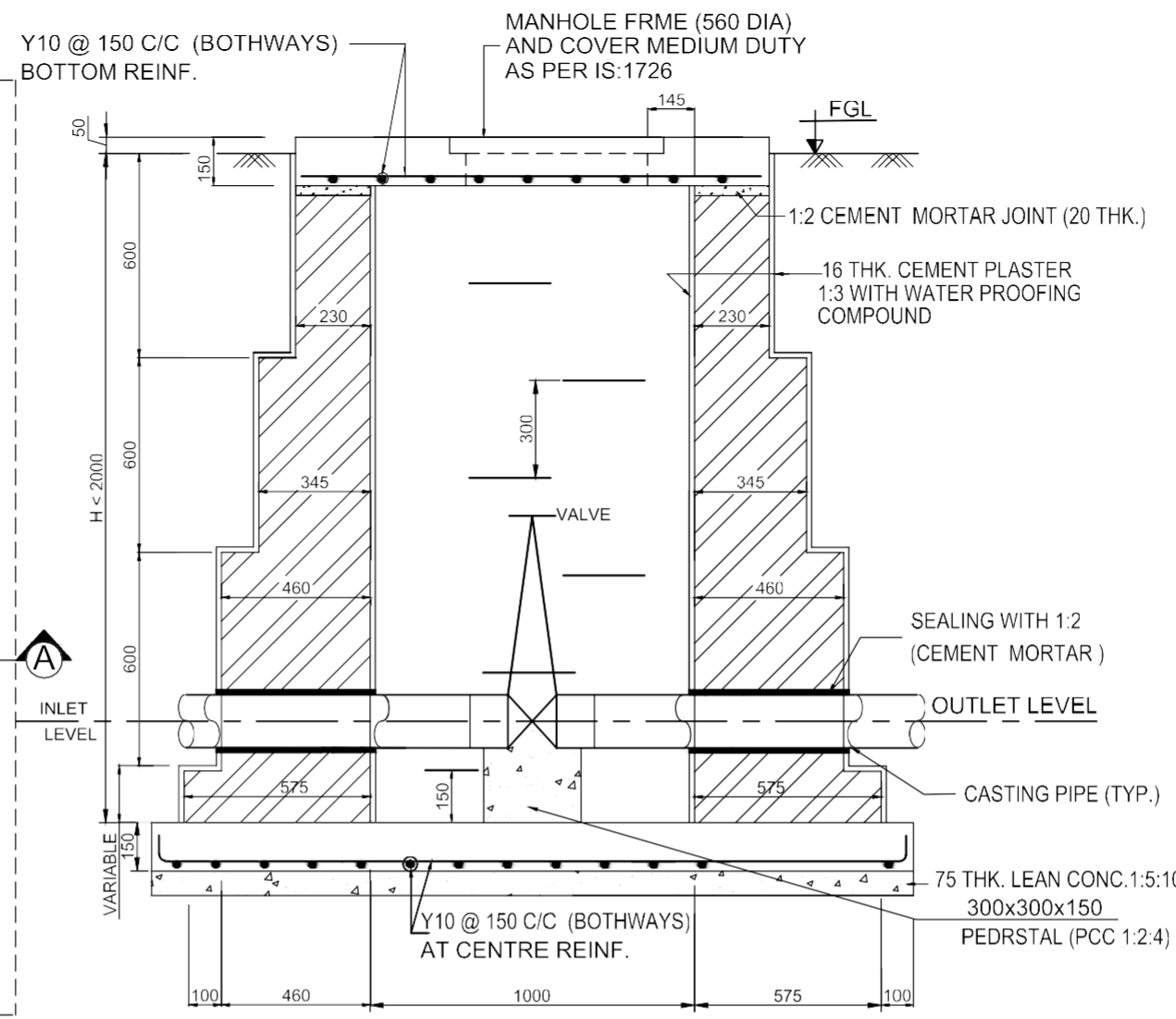

SECTION A-A
(SCALE 1:20)

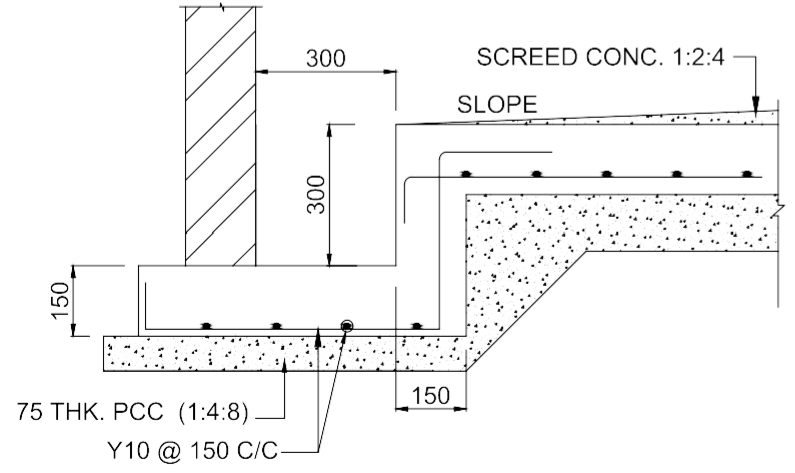

SECTION 1-1
(SCALE 1:15)

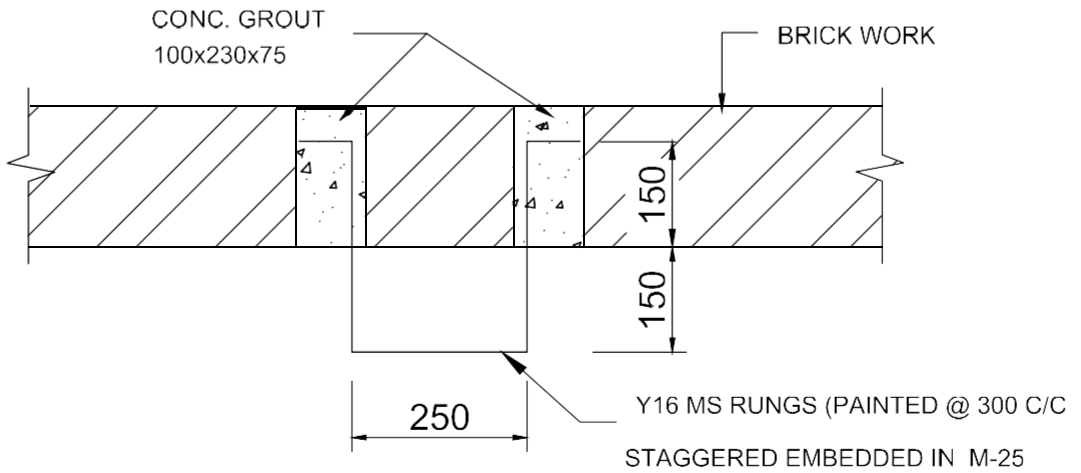

TYPICAL DETAILS OF MS RUNGS
(SCALE 1:10)

- NOTES:-**
1. ALL DIMENSIONS ARE IN MM UNLESS NOTED OTHERWISE.
 2. FOLLOW WRITTEN DIMENSIONS ONLY. DO NOT SCALE THE DRAWING.
 3. CLEAR COVER TO MAIN REINFORCEMENT SHALL BE (a) SLAB 20mm
 4. GRADE OF CONCRETE USED SHALL BE M-25 CONFORMING.
 5. REINFORCEMENT SHALL BE HYSD BARS OF (GRADE Fe 415) CONFORMING TO IS:1786.

OWNER:		HPOIL GAS PRIVATE LIMITED.	
PMC:		M/s. VCS QUALITY SERVICES PVT. LTD.	
PROJECT:		LMC & DMA SERVICES AT AMBALA-KURUKSHETRA GA	
TITLE:		STANDARD DETAIL OF BRICK VALVE CHAMBER (TYPE-2)	
SCALE AS SHOWN	DATE 01-07-2014	CAD FILE DATE	CAD A3

- NOTES:-**
1. ALL DIMENSIONS ARE IN MM UNLESS NOTED OTHERWISE.
 2. FOLLOW WRITTEN DIMENSIONS ONLY. DO NOT SCALE THE DRAWINGS.
 3. A MODIFIED PIPELINE WARNING SIGN SHALL BE INSTALLED CLOSE TO THE CROSSING.
 4. IN CASE OF ARMoured OFC CABLE, C.P. BONDING IS TO BE PROVIDED BETWEEN PIPELINE AND CABLE ARMOUR. IN CASE OF UNARMoured CABLE, ARRANGEMENT FOR SHIELDING (BY PROVIDING CASING ON EITHER SIDE OF THE PIPELINE OR CABLE) SHALL BE CONSIDERED.
 5. APPROVAL OF THE CROSSING SHALL BE OBTAINED FROM CONCERNED AUTHORITIES.

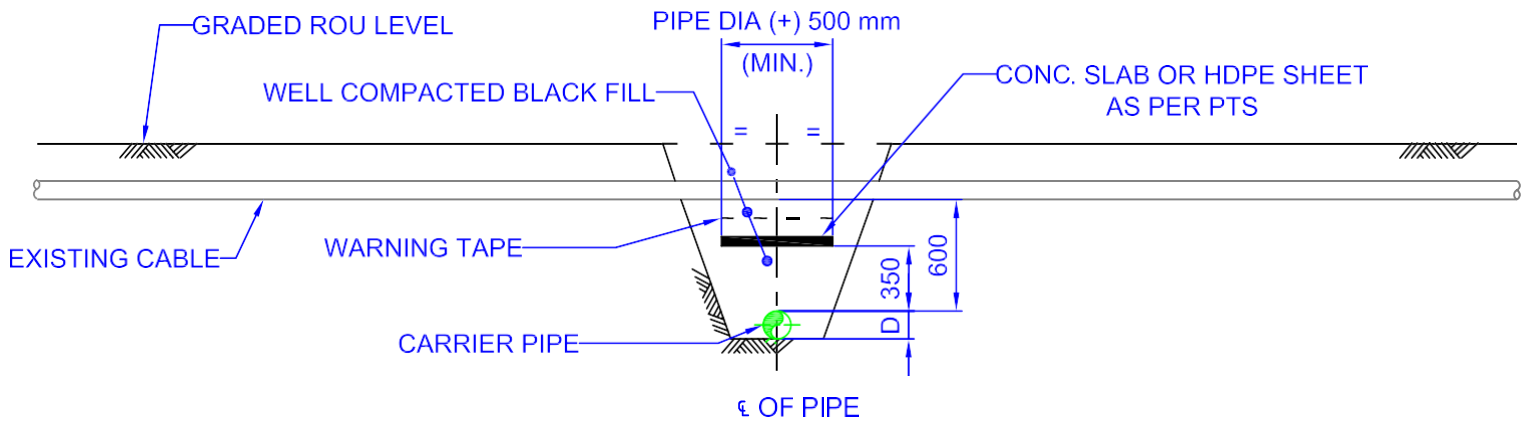
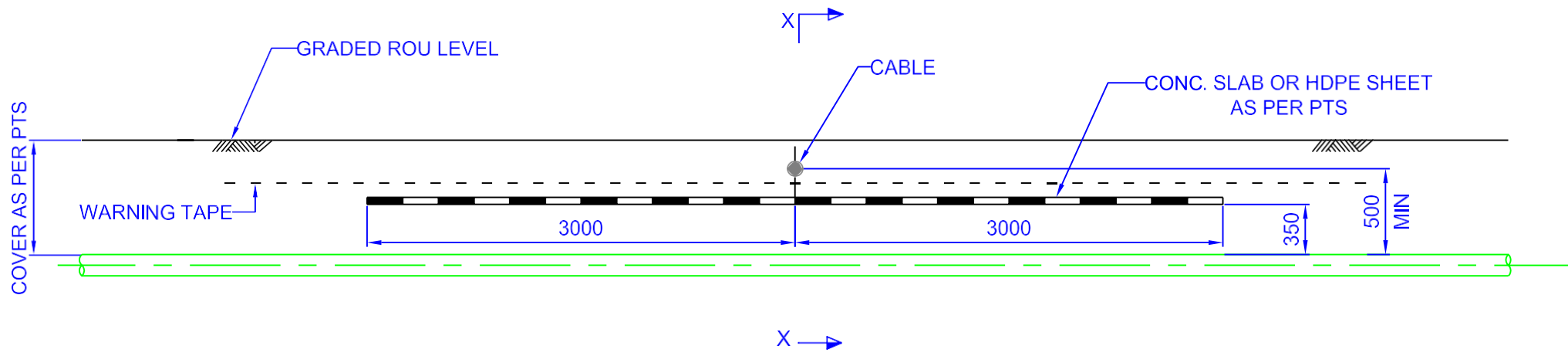

SECTION X-X

OWNER:				
PMC: M/s. VCS QUALITY SERVICES PVT. LTD.				
PROJECT:				
TITLE: TYPICAL UNDERGROUND CABLE CROSSING DETAILS				
SCALE: 1:2	DATE:	CAD FILE: DATE:	CAD	A3
DRG. NO. -10-03-24 REV-0				

A

B

C

D

E

A

B

C

D

E

NOTES:-

- 1. ALL DIMENSIONS ARE IN MM UNLESS NOTED OTHERWISE.
- 2. FOLLOW WRITTEN DIMENSIONS ONLY. DO NOT SCALE THE DRAWINGS.

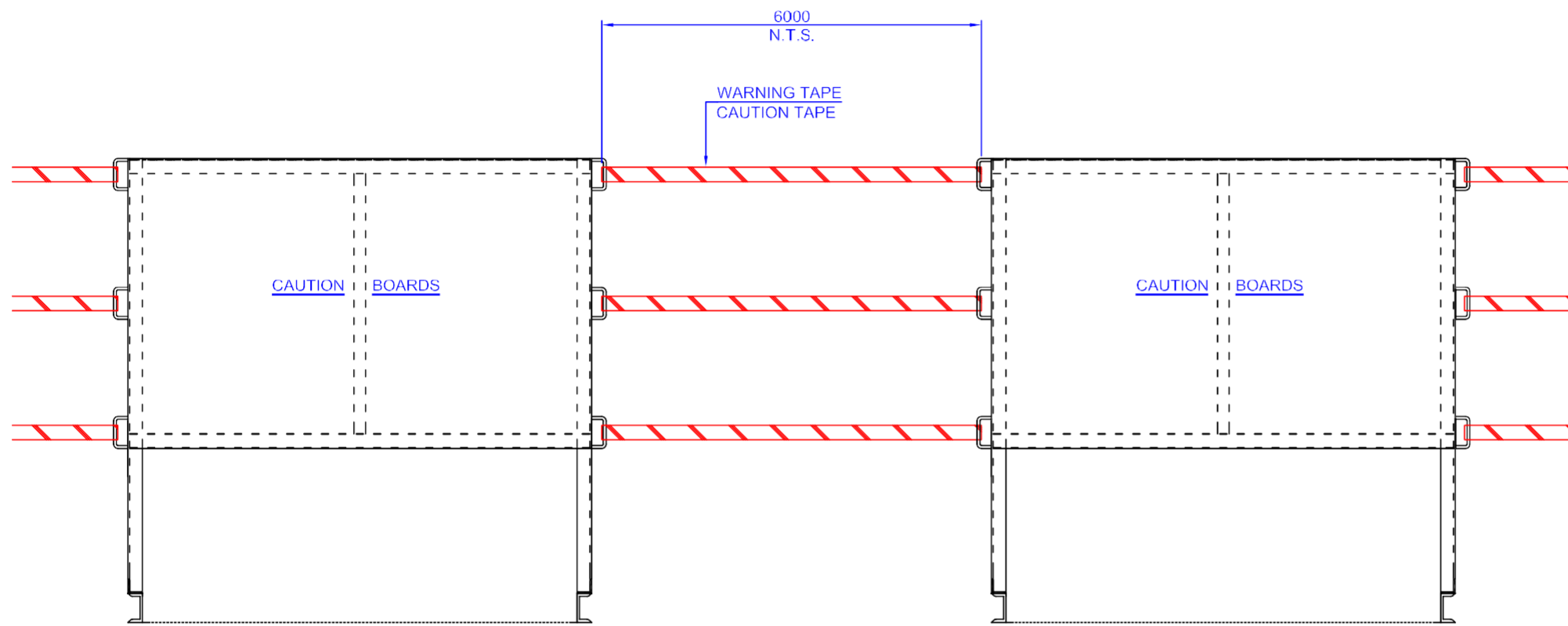

SCHEMATIC LAYOUT OF CAUTION BOARDS AND BARRICADING

OWNER:



PMC:



M/s. VCS QUALITY SERVICES PVT. LTD.

PROJECT:

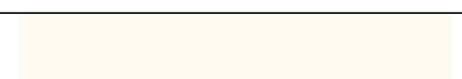

TITLE:

BARRICADING

SCALE	DATE	CAD FILE	CAD	A3

DRG. NO. -10-03-26 REV-0

NOTES:-
 1. ALL DIMENSIONS ARE IN MM UNLESS NOTED OTHERWISE.
 2. FOLLOW WRITTEN DIMENSIONS ONLY. DO NOT SCALE THE DRAWINGS.

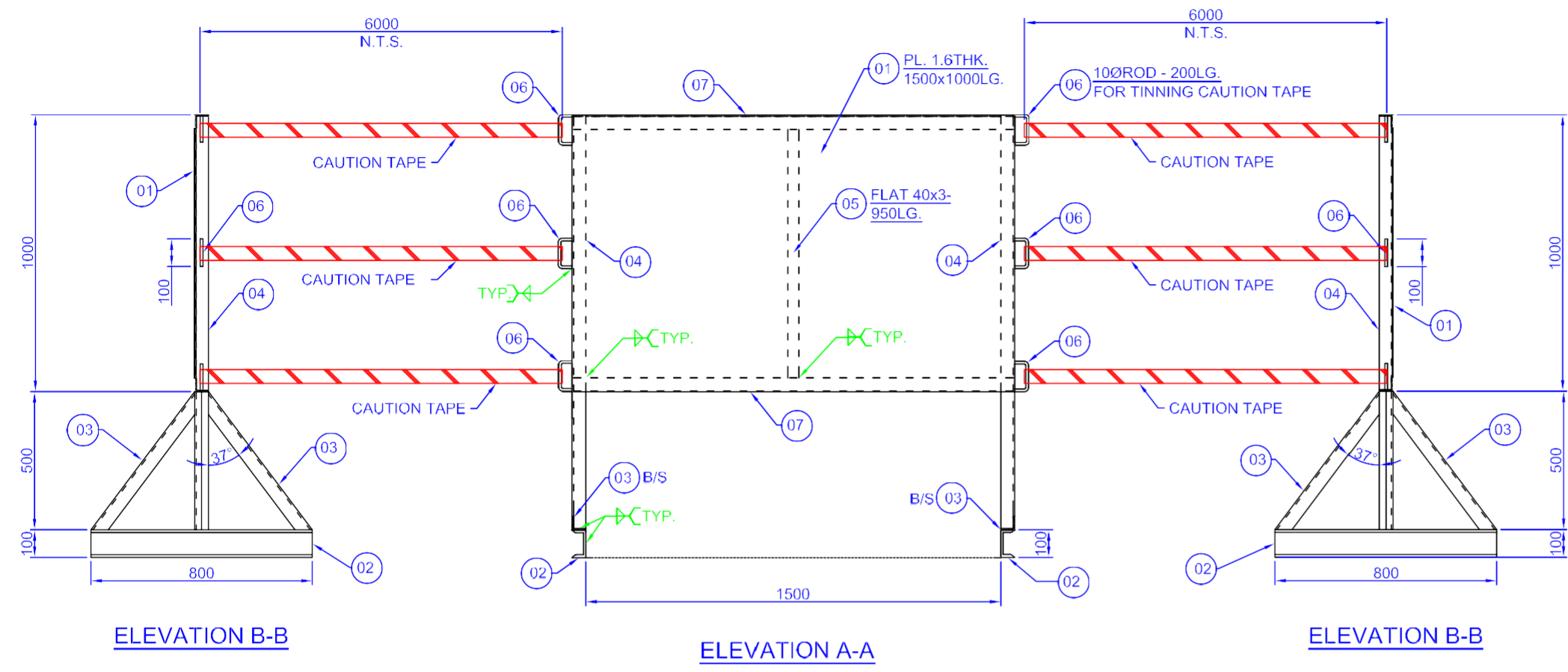

CAUTION
 WORK IN PROGRESS

IN RED →

← CLIENT LOGO

IN BLACK {
 LAYING OF NATURAL GAS PIPELINE
 CLIENT : OWNER'S NAME
 CONTRACTOR NAME:
 DATE OF COMMENCEMENT:
 DATE OF COMPLETION:
 EMERGENCY PHONE NOS.:

TO BE PRINTED ON ITEM NO. 01

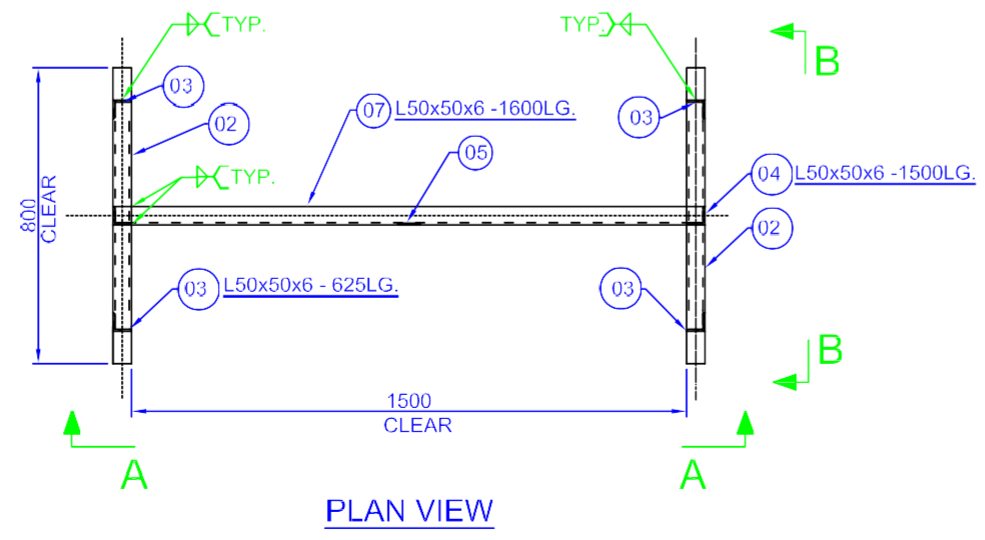

BILL OF MATERIAL						
Item Mkd.	Section	Width	Length	Item Qty.	Weight	Total Weight
				(All Marks)	Kgs./M.M2	In Kgs.
1.	PL. 1.6 THK.	1600	1000	1	12.56	20.10
2.	ISMC 100	--	800	2	9.20	14.72
3.	L50x50x6	--	625	4	4.50	11.25
4.	L50x50x6	--	1500	2	4.50	13.50
5.	Flat 3Thk.	900	40	1	0.94	0.03
6.	10Ø Rod	--	200	6	0.62	0.74
7.	L50x50x6	--	1600	2	4.50	14.40
					Grand Total (Kg)	74.74

OWNER:

PMC:
M/s. VCS QUALITY SERVICES PVT. LTD.

PROJECT:

TITLE: CAUTION BOARD & TAPE ARRANGEMENT IN G.I. / RISER INSTALLATION

SCALE: DATE: CAD FILE: DATE: CAD A3

DRG. NO. -10-03-26A

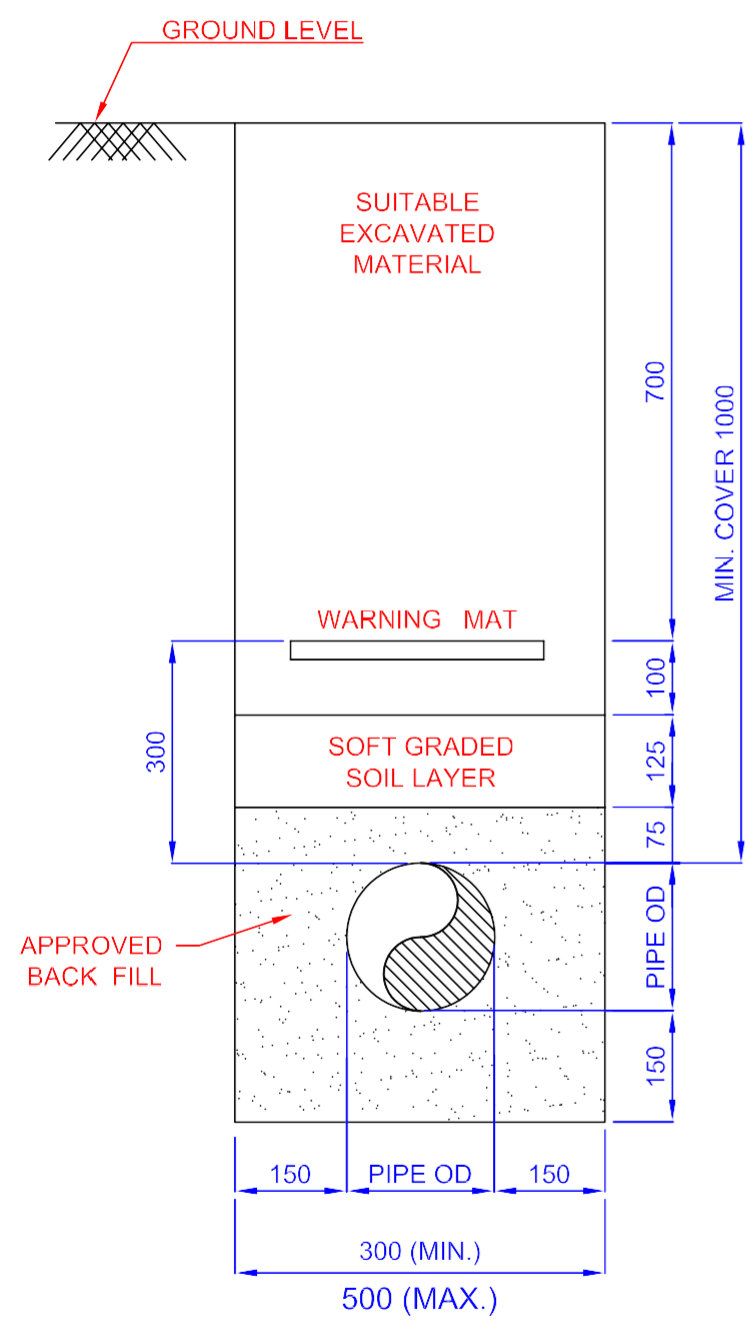

**TRENCH IN ROCKY STRATA
TYPICAL SECTION**

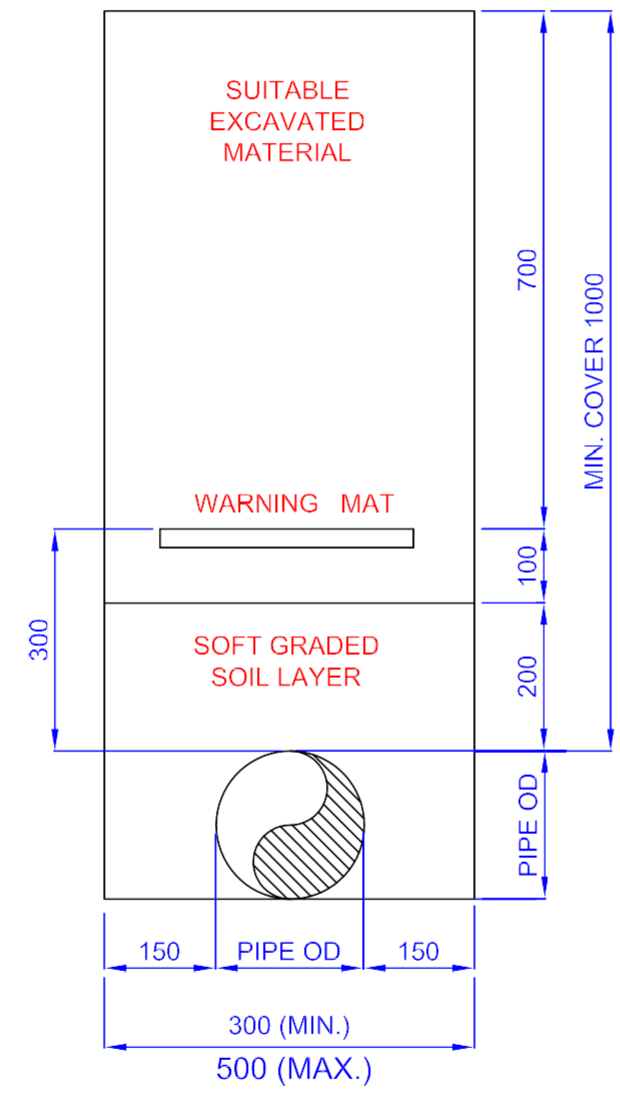

**TRENCH IN NORMAL SOIL
TYPICAL SECTION**

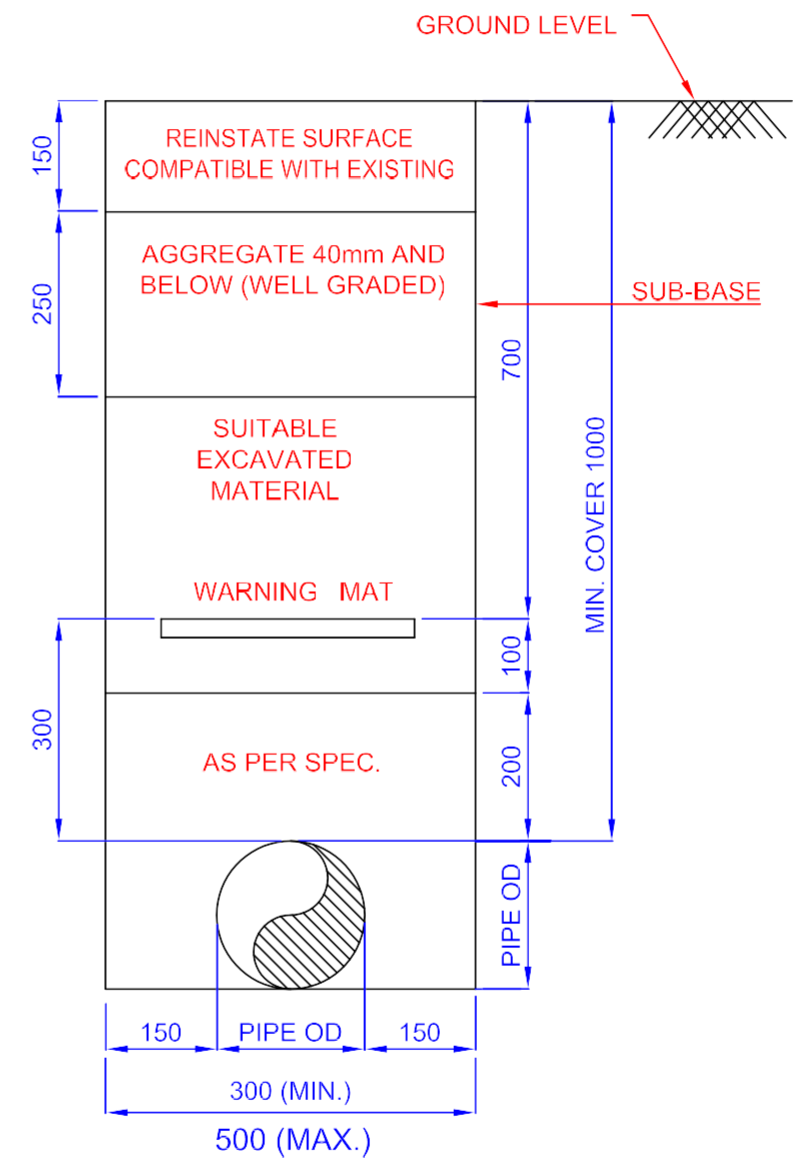

**TRENCH RESTORATION DETAIL
TYPICAL SECTION**

- NOTES:-**
1. ALL DIMENSIONS ARE IN MM UNLESS NOTED OTHERWISE.
 2. FOLLOW WRITTEN DIMENSIONS ONLY. DO NOT SCALE THE DRAWING.
 3. FOR ALL PIPELINE TO BE CONSTRUCTED IN THE LAND UNDER JURISDICTION OF GOVT. OF INDIA, THE MIN COVER TO BE ADOPTED SHALL BE 1000MM IN ACCORDANCE WITH GOVT. OF INDIA PETROLEUM PIPELINE (ACQUISITION OF RIGHT OF USER IN LAND) ACT NO. 50, 1962 AND AMENDMENT ACT NO. 13 OF 1977. ANY EXTRA COVER REQUIREMENT SHALL BE IN ACCORDANCE WITH SPECIFICATIONS.
 4. MIN. COVER REQUIREMENT SHALL BE SUBJECT TO APPROVAL OF CONCERNED AUTHORITIES WHEREVER REQUIRED.
 5. EXTRA COVER REQUIREMENT SHALL BE ESTABLISHED AT ALL OVER BE NOS AND HORIZONTAL BE NOS WHEREVER NECESSARY.
 6. FOR MINIMUM COVER REQUIREMENT AT PIPELINE CROSSING ROADS, RAILWAY TRACKS, RIVER MARSHY AREAS, ETC., REFER RELEVANT STANDARDS.

OWNER:				
PMC:				
M/s. VCS QUALITY SERVICES PVT. LTD.				
PROJECT:				
TITLE: TYPICAL TRENCH DIMENSIONS FOR PIPELINE				
SCALE: 1:10	DATE:	CAD FILE: DATE:	CAD	A3
DRG. NO. -10-03-27 REV-0				

NOTES:-

300

WARNING

22

250

15 -

CLIENT: HPOIL GAS PRIVATE LIMITED



TITLE PLATE MARKER

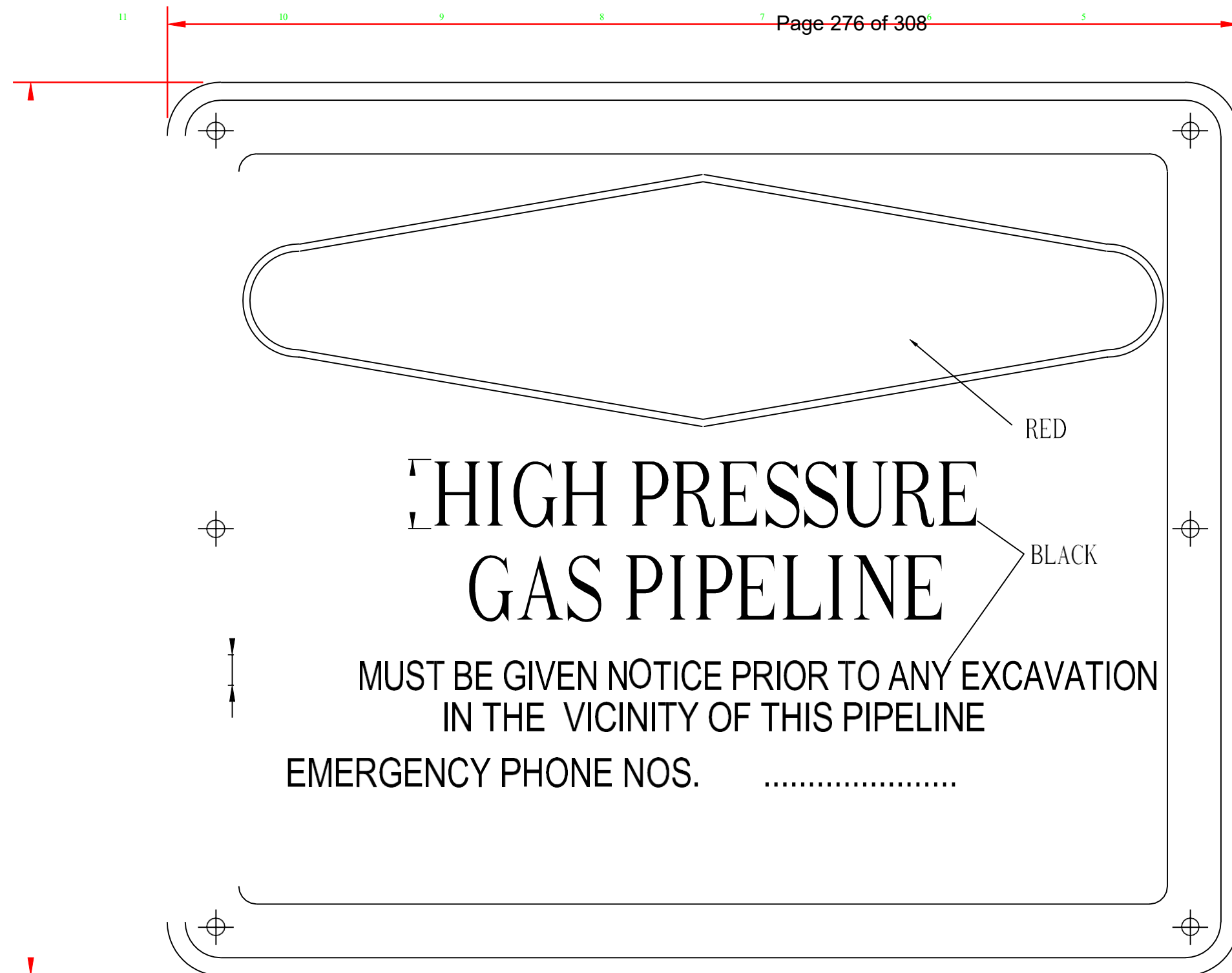

**HIGH PRESSURE
GAS PIPELINE**

MUST BE GIVEN NOTICE PRIOR TO ANY EXCAVATION
IN THE VICINITY OF THIS PIPELINE

EMERGENCY PHONE NOS.

M.S PLATE 3.0 MM (MIN.) THK.

POWDER COATED GOLDEN YELLOW



M/s. VCS QUALITY SERVICES PVT. LTD.

L	/

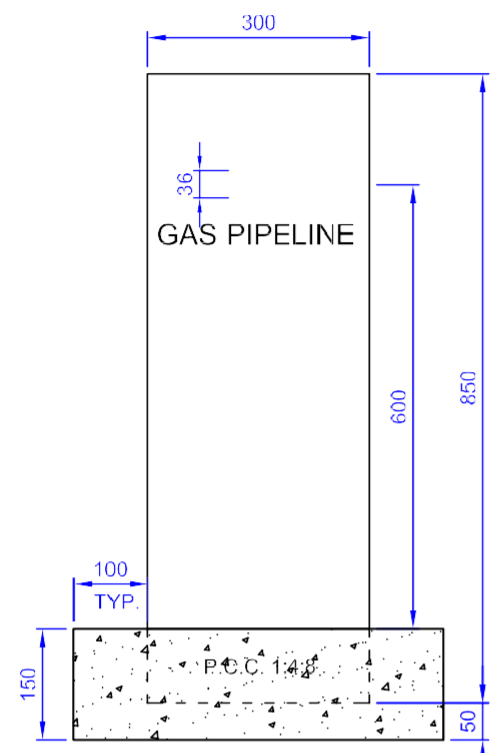

SECTION A-A

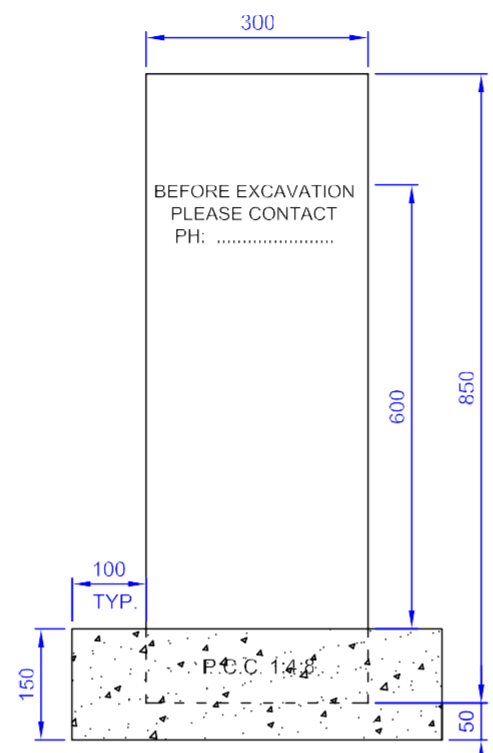

SECTION B-B

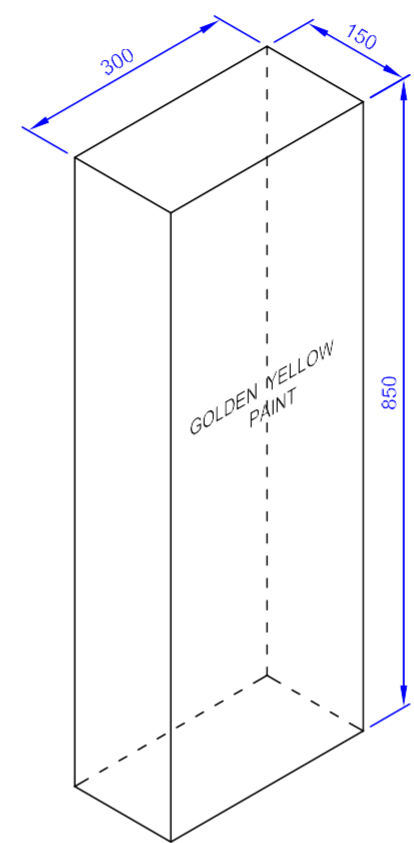

ISOMETRIC VIEW

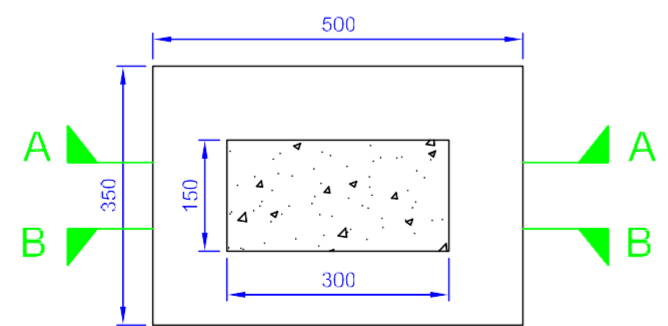

PLAIN VIEW

NOTES:-

1. ALL DIMENSIONS ARE IN MM UNLESS NOTED OTHERWISE.
2. FOLLOW WRITTEN DIMENSIONS ONLY. DO NOT SCALE THE DRAWING.
3. ALL TEXT SHOULD BE WRITTEN IN BLACK COLOR.

OWNER:				
PMC:				
M/s. VCS QUALITY SERVICES PVT. LTD.				
PROJECT:				
TITLE:				
SKETCH FOR STONE MARKER				
SCALE	DATE	CAD FILE	CAD	A3
1:10				
DRG. NO. -10-03-29 REV-0				

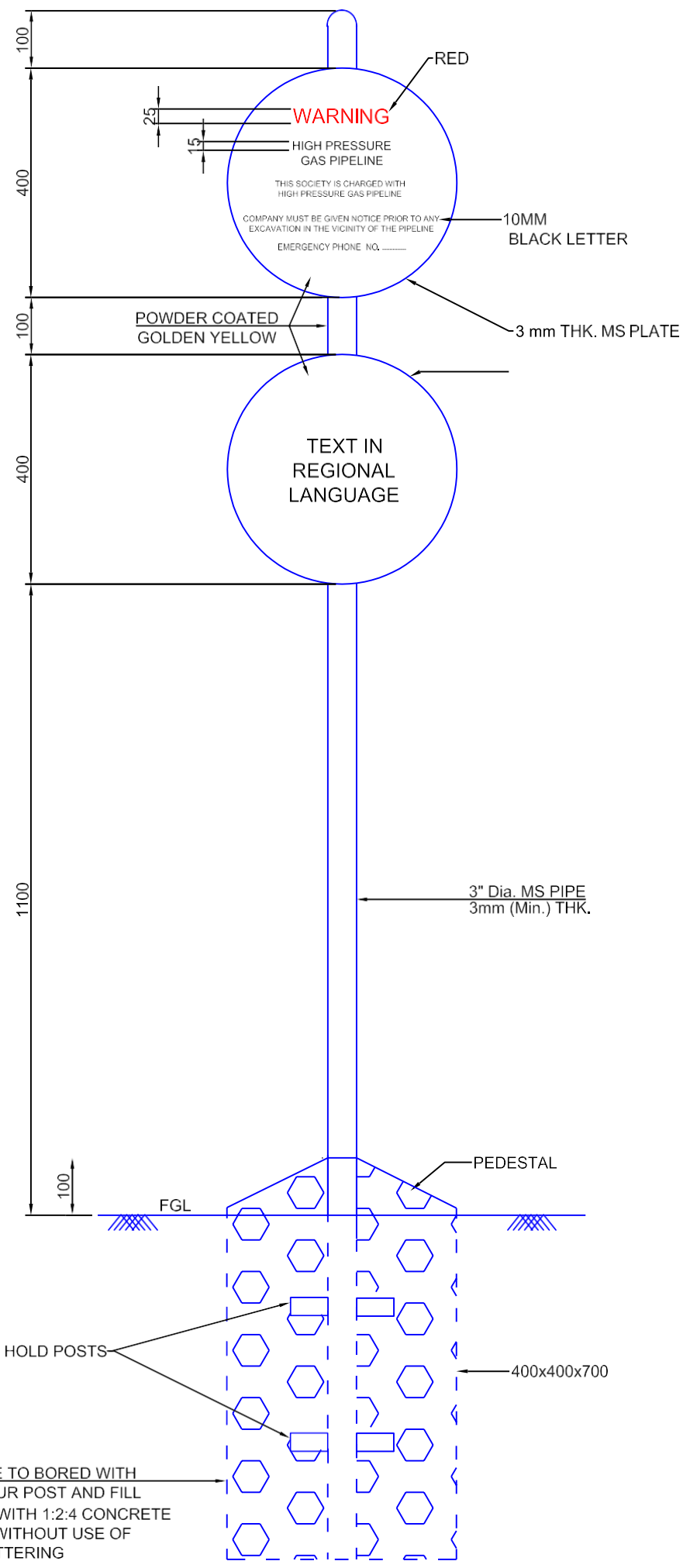

FIXING DETAILS

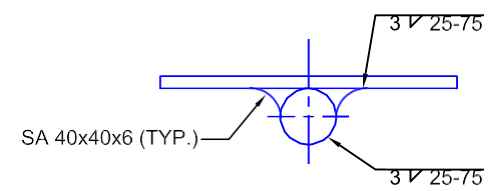
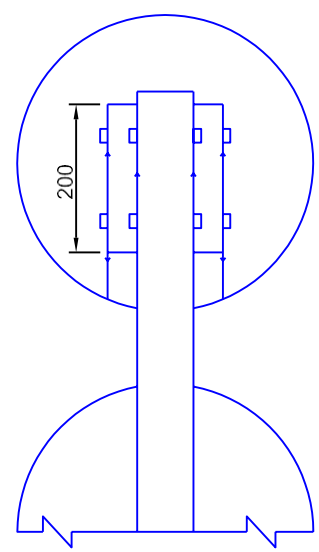

NOTES:-

1. ALL DIMENSIONS ARE IN MM UNLESS NOTED OTHERWISE.
2. WARNING TEXT AND MARKER SIZES ARE INDICATIVE AND ARE SUBJECT TO THE APPROVAL BY OWNER / OWNER'S REPRESENTATIVE BEFORE FABRICATION.
3. SCHEME FOR POWDER COATING AND COLORING : ONE COAT OF PRIMER & TWO COATS OF SPECIFIED PAINTS. ALL LETTERS EXCEPT 'WARNING' TO BE PAINTED BLACK.
4. APPROVAL OF WARNING MARKER DESIGN SHALL BE OBTAINED BEFORE THE COMMENCEMENT OF WORK.

OWNER:



PMC:



M/s. VCS QUALITY SERVICES PVT. LTD.

PROJECT:

TITLE: POLE MARKER WITH FOUNDATION (INDIVIDUAL SOCIETIES / AREAS)

SCALE: 1:10	DATE:	CAD FILE: DATE:	CAD	A3
-------------	-------	-----------------	-----	----

DRG. NO. -10-03-30 REV-0

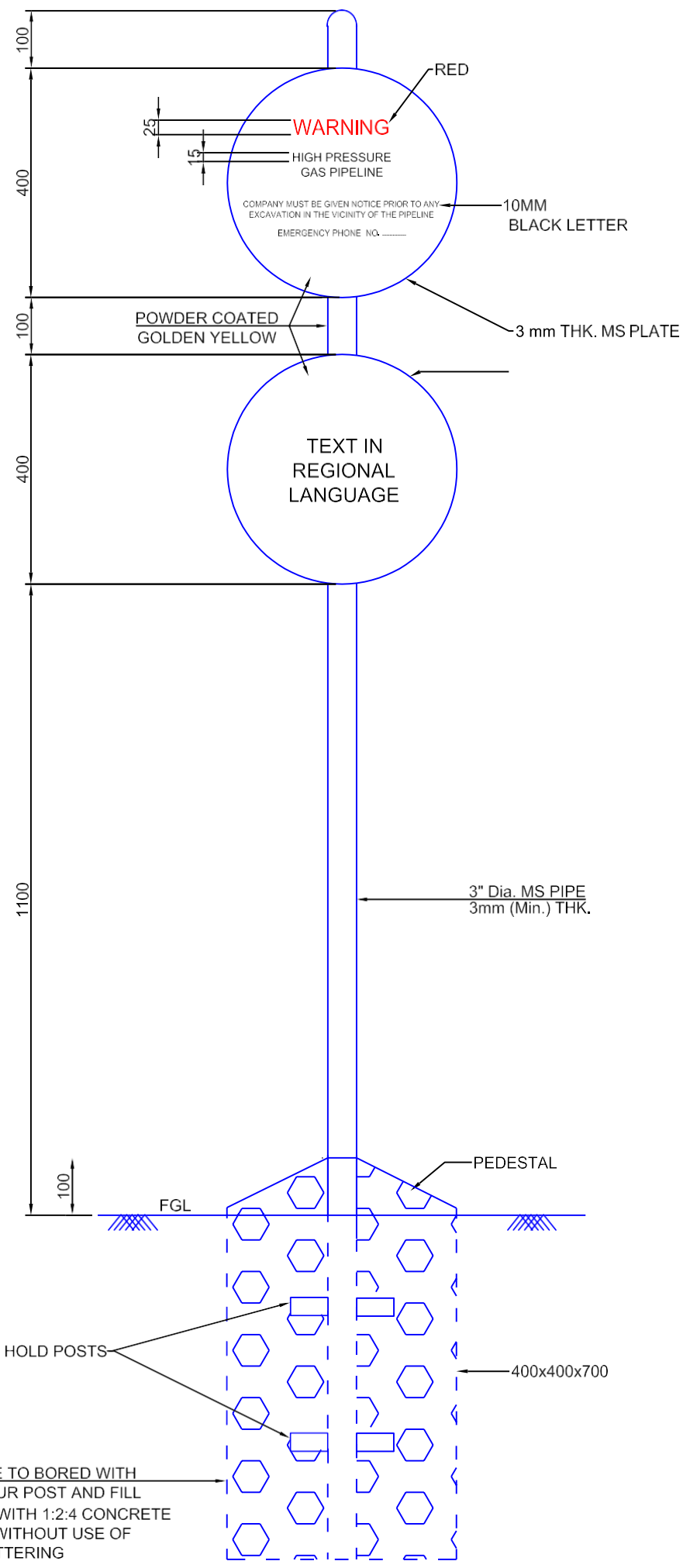

FIXING DETAILS

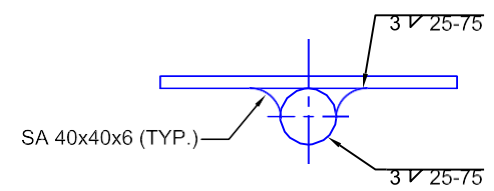
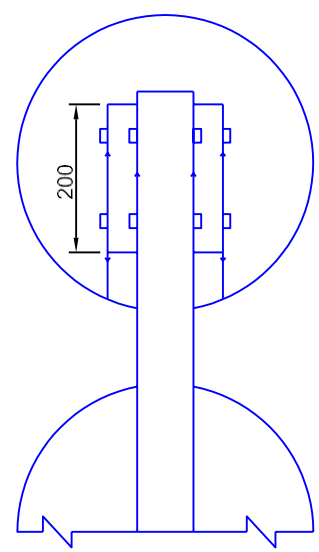

- NOTES:-**
1. ALL DIMENSIONS ARE IN MM UNLESS NOTED OTHERWISE.
 2. WARNING TEXT AND MARKER SIZES ARE INDICATIVE AND ARE SUBJECT TO THE APPROVAL BY OWNER / OWNER'S REPRESENTATIVE BEFORE FABRICATION.
 3. SCHEME FOR POWDER COATING AND COLORING : ONE COAT OF PRIMER & TWO COATS OF SPECIFIED PAINTS. ALL LETTERS EXCEPT 'WARNING' TO BE PAINTED BLACK.
 4. APPROVAL OF WARNING MARKER DESIGN SHALL BE OBTAINED BEFORE THE COMMENCEMENT OF WORK.

OWNER:			
PMC: M/s. VCS QUALITY SERVICES PVT. LTD.			
PROJECT:			
TITLE: POLE MARKER WITH FOUNDATION			
SCALE: 1:10	DATE:	CAD FILE: DATE:	CAD A3
DRG. NO. -10-03-31 REV-0			

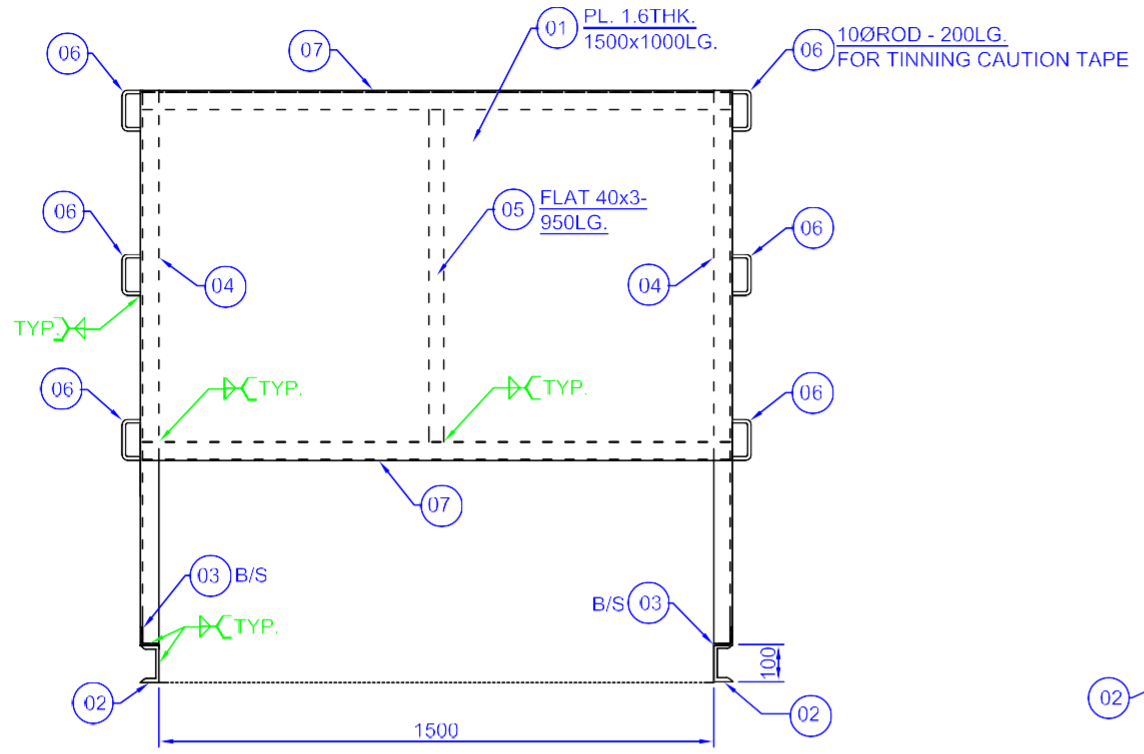

ELEVATION A-A

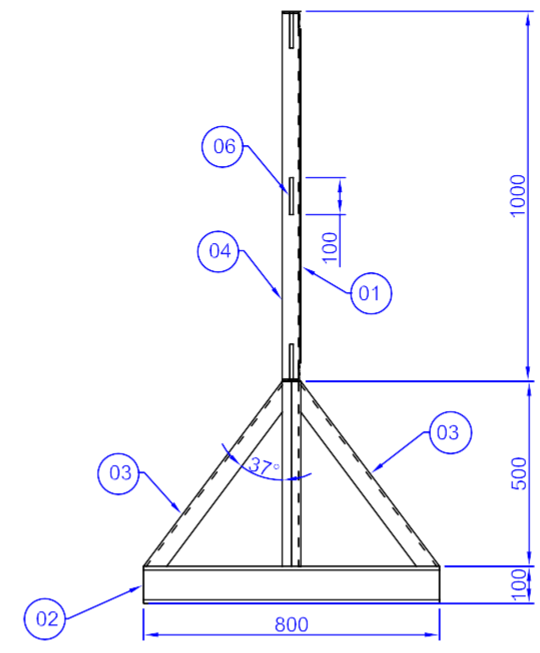

ELEVATION B-B

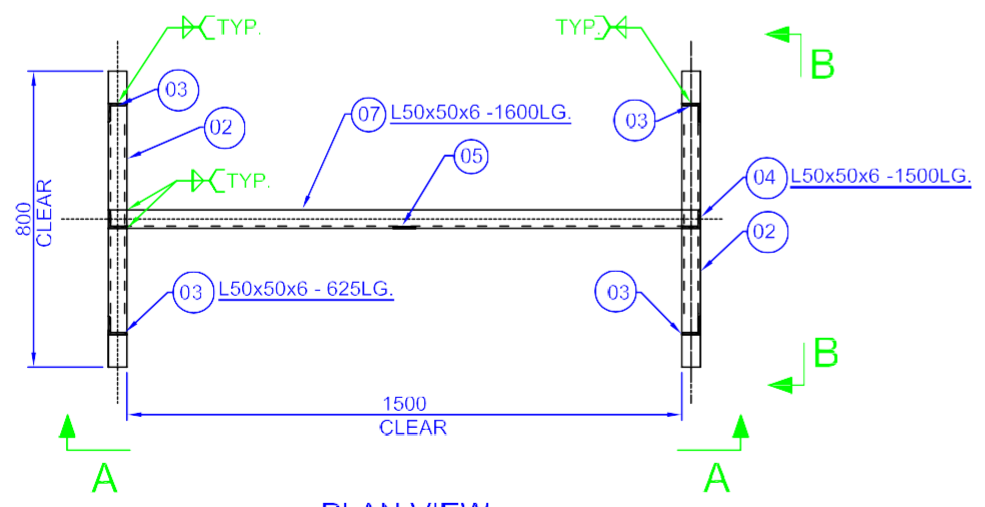

PLAN VIEW

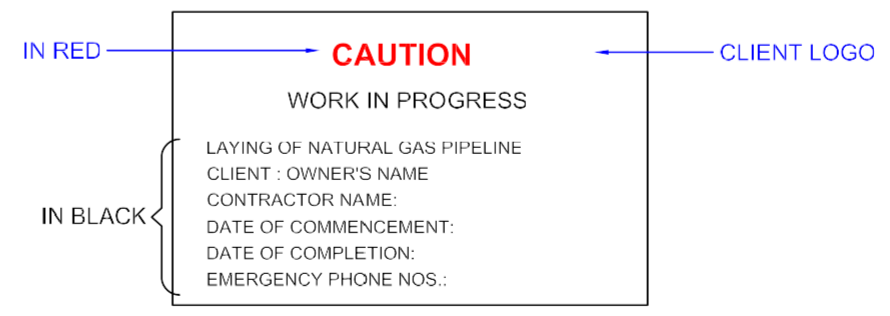

TO BE PRINTED ON ITEM NO. 01

NOTES:-

1. ALL DIMENSIONS ARE IN MM UNLESS NOTED OTHERWISE.
2. FOLLOW WRITTEN DIMENSIONS ONLY. DO NOT SCALE THE DRAWINGS.

BILL OF MATERIAL

Item Mkd.	Section	Width	Length	Item Qty.	Weight	Total Weight
					(All Marks) Kgs./M.M2	In Kgs.
1.	PL. 1.6 THK.	1600	1000	1	12.56	20.10
2.	ISMC 100	--	800	2	9.20	14.72
3.	L50x50x6	--	625	4	4.50	11.25
4.	L50x50x6	--	1500	2	4.50	13.50
5.	Flat 3Thk.	900	40	1	0.94	0.03
6.	10Ø Rod	--	200	6	0.62	0.74
7.	L50x50x6	--	1600	2	4.50	14.40
					Grand Total (Kg)	74.74

OWNER:



PMC:

M/s. VCS QUALITY SERVICES PVT. LTD.

PROJECT:

TITLE:

CAUTION BOARD

SCALE	DATE	CAD FILE: DATE	CAD	A3
-------	------	----------------	-----	----

DRG. NO. -10-03-32 REV-0

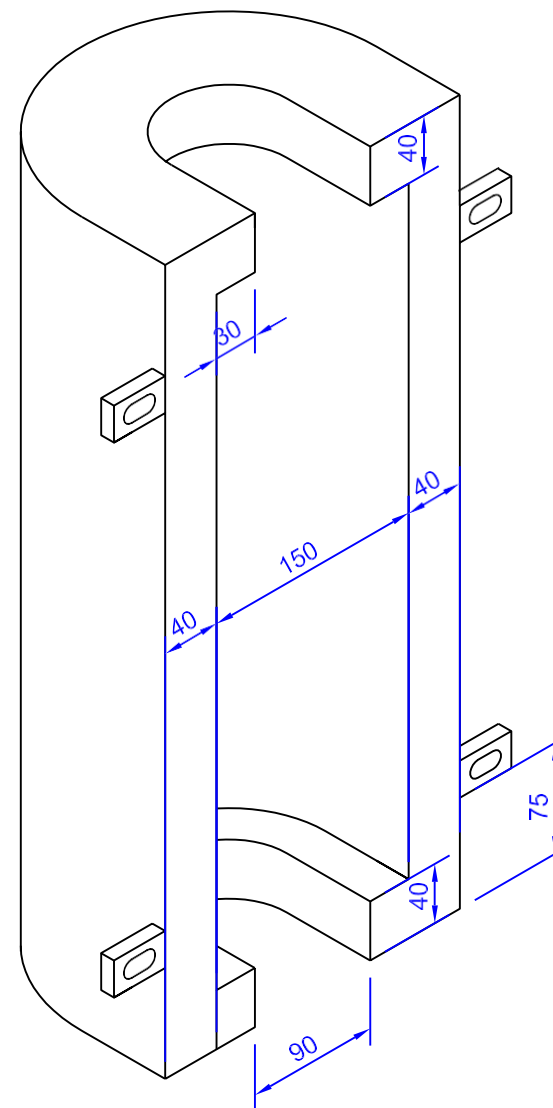
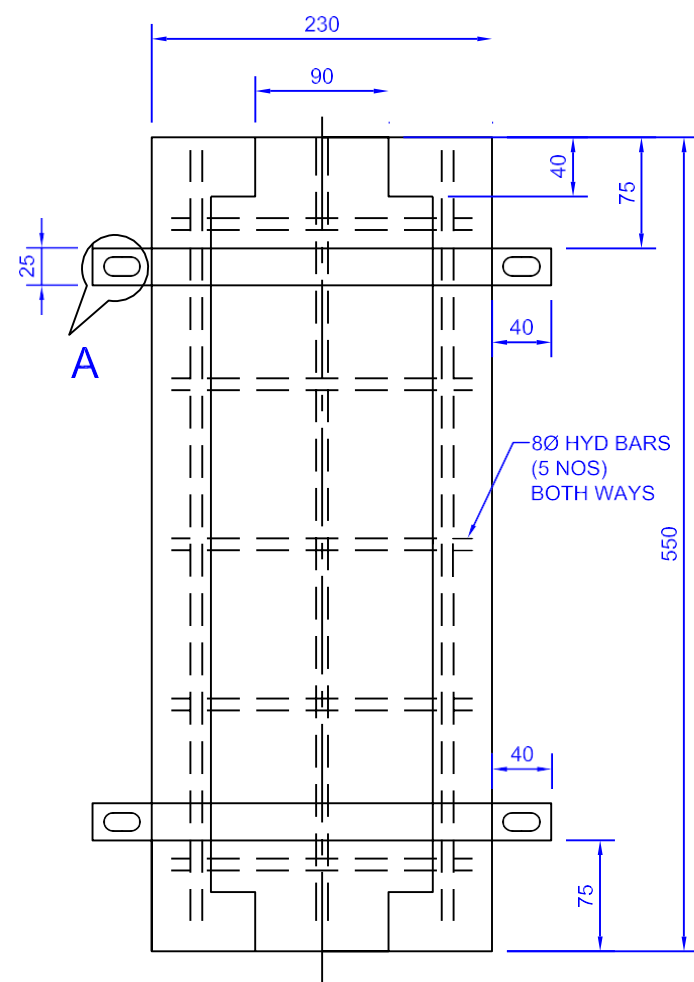
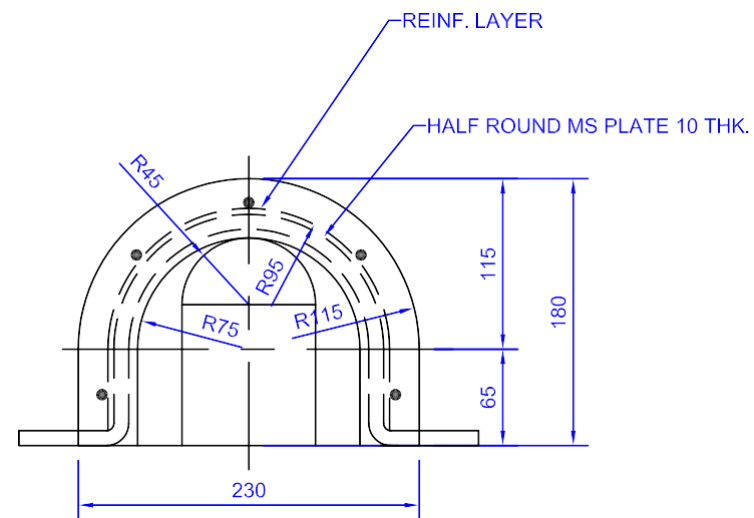

ISOMETRIC VIEW

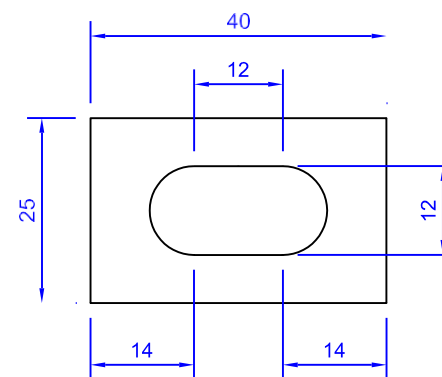

DETAIL-A
SCALE 1:1

NOTES:-

1. ALL DIMENSIONS ARE IN MM UNLESS NOTED OTHERWISE.
2. FOLLOW WRITTEN DIMENSIONS ONLY. DO NOT SCALE THE DRAWING.
3. GRADE OF CONCRETE SHALL BE M25.
4. REINFORCEMENT IS HYD. TO IS:1786.
5. CONCRETE SLEEVE TO BE CLAMPED TO WALL WITH 10Ø ANCHOR BOLTS.

OWNER:



PMC:



M/s. VCS QUALITY SERVICES PVT. LTD.

PROJECT:

TITLE:

HALF ROUND CONCRETE SLEEVE

SCALE 1:5	DATE	CAD FILE: DATE	CAD	A3
--------------	------	-------------------	-----	----

DRG. NO. -10-03-33 REV-0

NOTES:-

1. ALL DIMENSIONS ARE IN MM UNLESS NOTED OTHERWISE.
2. FOLLOW WRITTEN DIMENSIONS ONLY. DO NOT SCALE THE DRAWING.

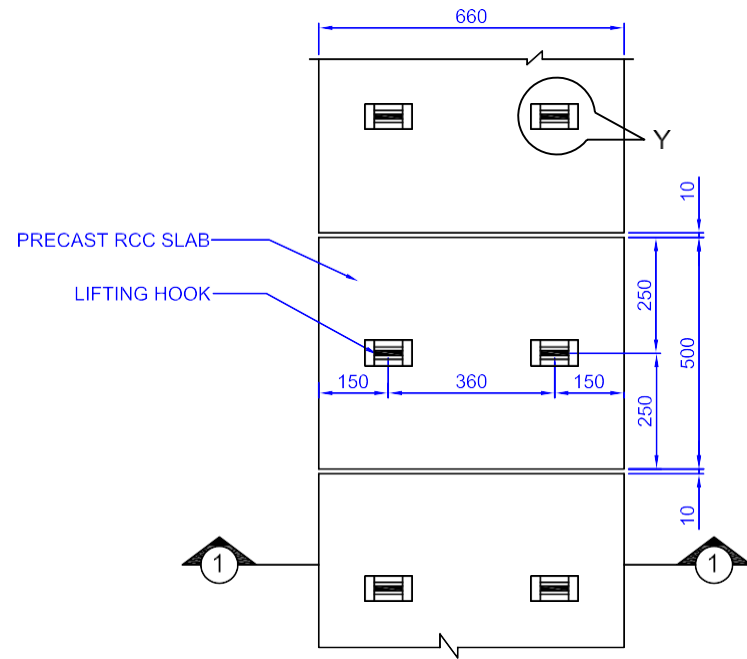

G.A PLAN OF COVER SLAB

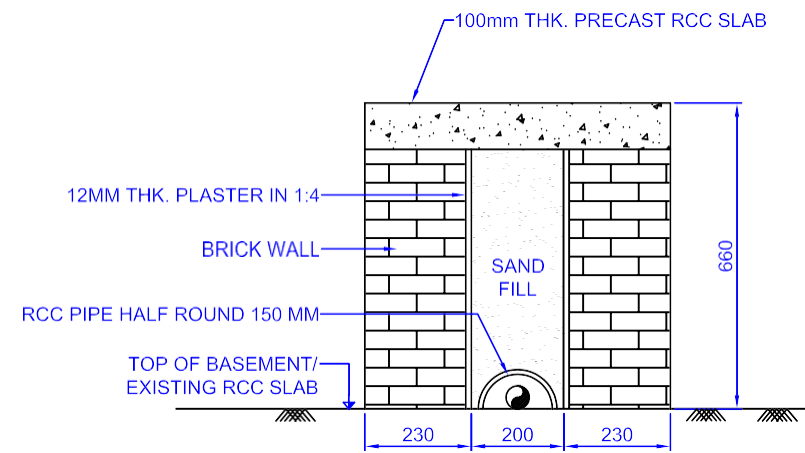

SECTION 1-1 THRU PIPE TRENCH

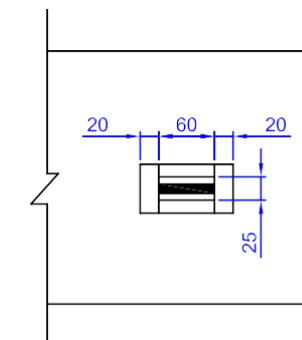

**DETAIL - Y
SCALE 1:8**

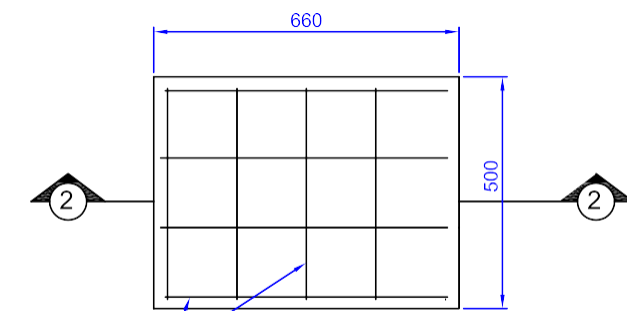

PRECAST RCC SLAB

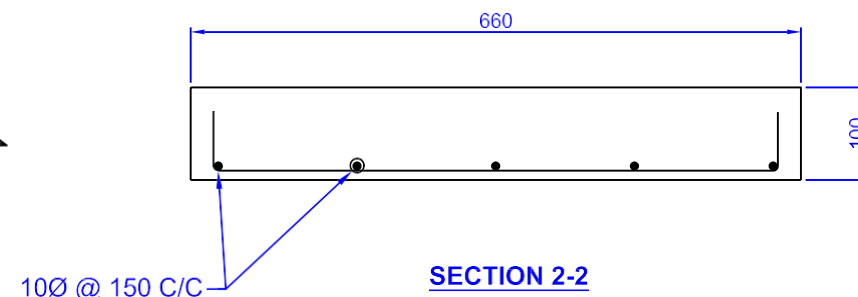

**SECTION 2-2
SCALE 1:8**

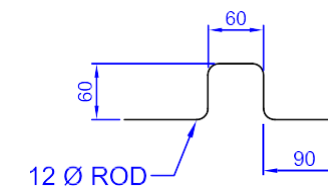

**LIFTING HOOK
SCALE 1:8**

OWNER:



PMC:



M/s. VCS QUALITY SERVICES PVT. LTD.

PROJECT:

**TITLE: TYPICAL BRICK WALL TRENCH
(0.66 X 0.66 X 1.0)**

SCALE 1:16	DATE	CAD FILE: DATE	CAD	A3
---------------	------	-------------------	-----	----

DRG. NO. -10-03-34 REV-0

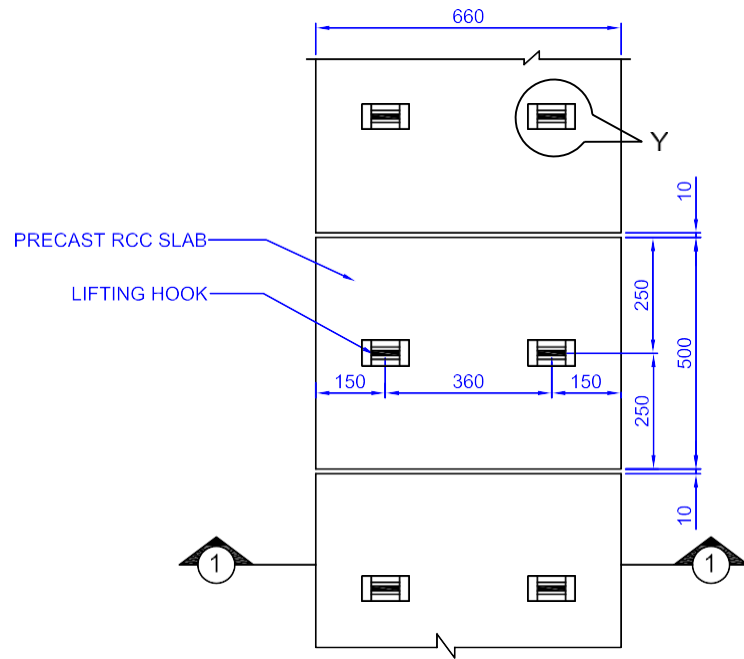

G.A PLAN OF COVER SLAB

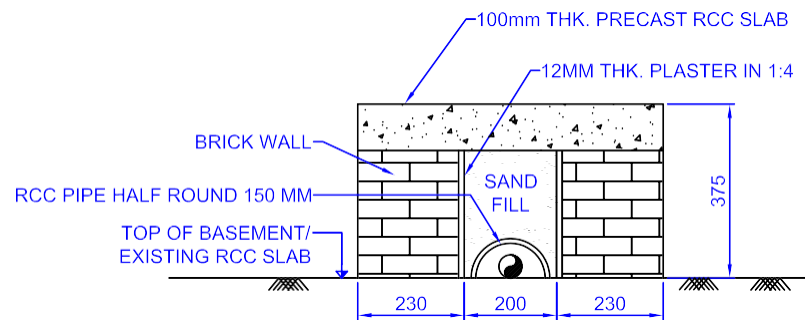

SECTION 1-1 THRU PIPE TRENCH

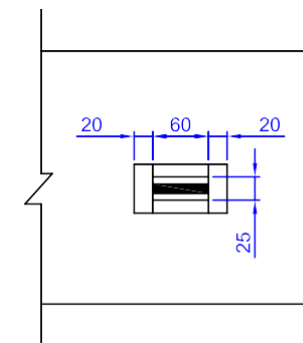

**DETAIL - Y
SCALE 1:8**

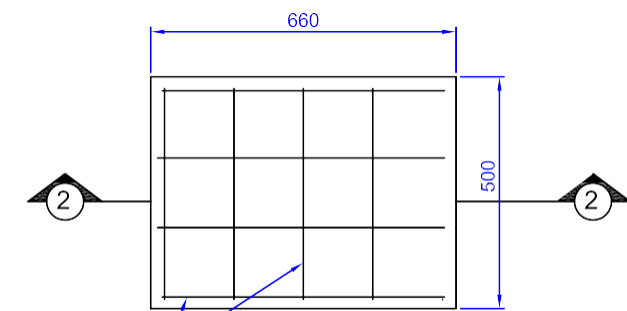

PRECAST RCC SLAB

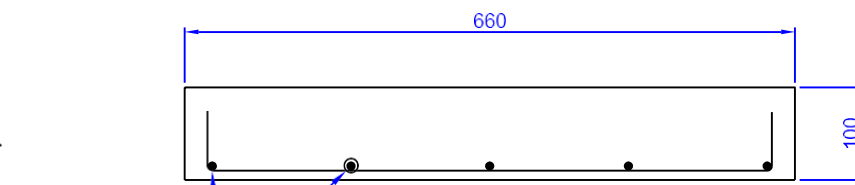

**SECTION 2-2
SCALE 1:8**

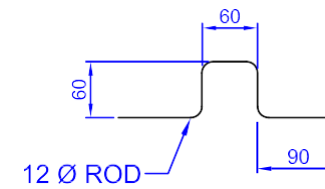

**LIFTING HOOK
SCALE 1:8**

NOTES:-

1. ALL DIMENSIONS ARE IN MM UNLESS NOTED OTHERWISE.
2. FOLLOW WRITTEN DIMENSIONS ONLY. DO NOT SCALE THE DRAWING.

OWNER:



PMC:



M/s. VCS QUALITY SERVICES PVT. LTD.

PROJECT:

**TITLE: TYPICAL BRICK WALL TRENCH
(0.375 X 0.66 X 1.0)**

SCALE 1:16	DATE	CAD FILE: DATE	CAD	A3
---------------	------	-------------------	-----	----

DRG. NO. -10-03-35 REV-0

NOTES:-
 1. ALL DIMENSIONS ARE IN MM UNLESS NOTED OTHERWISE.
 2. FOLLOW WRITTEN DIMENSIONS ONLY. DO NOT SCALE THE DRAWING.

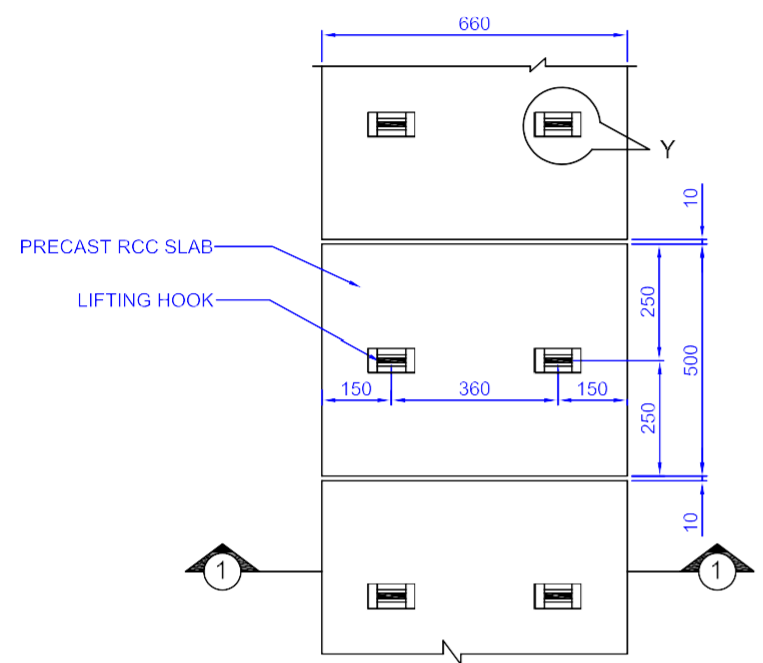

G.A PLAN OF COVER SLAB

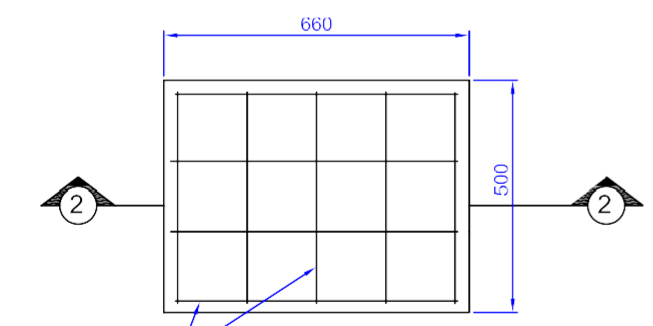

PRECAST RCC SLAB

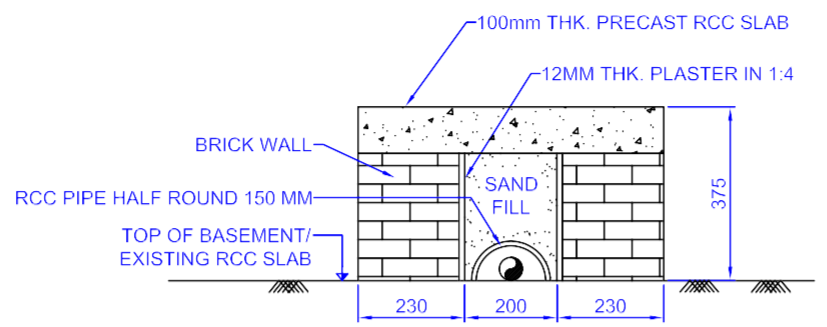

SECTION 1-1 THRU PIPE TRENCH

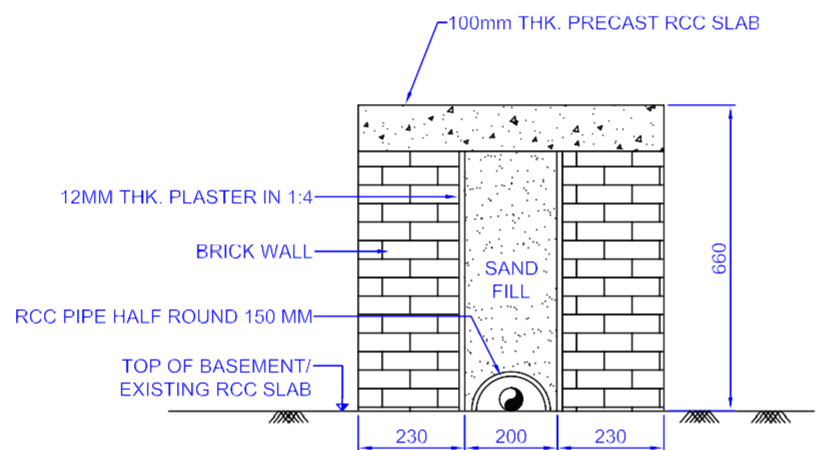

SECTION 1-1 THRU PIPE TRENCH

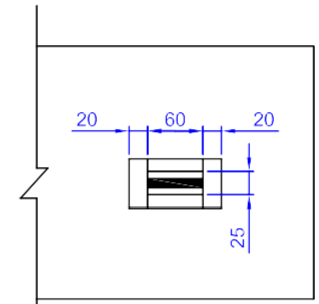

**DETAIL - Y
SCALE 1:8**

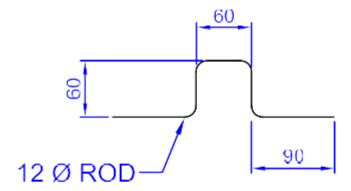

**LIFTING HOOK
SCALE 1:8**

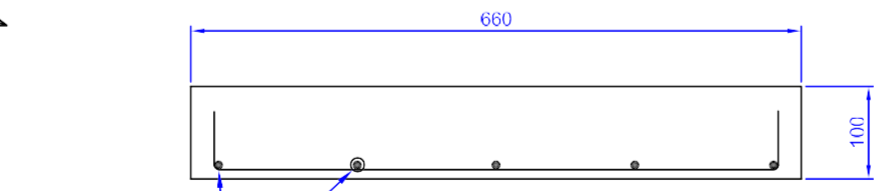

**SECTION 2-2
SCALE 1:8**

OWNER:			
PMC:			
M/s. VCS QUALITY SERVICES PVT. LTD.			
PROJECT:			
TITLE: TYPICAL BRICK WALL TRENCH UPTO 7M (ROAD CROSSING) INSIDE SOCIETY			
SCALE: 1:16	DATE:	CAD FILE: DATE:	CAD A3
DRG. NO.		-10-03-43 REV-0	

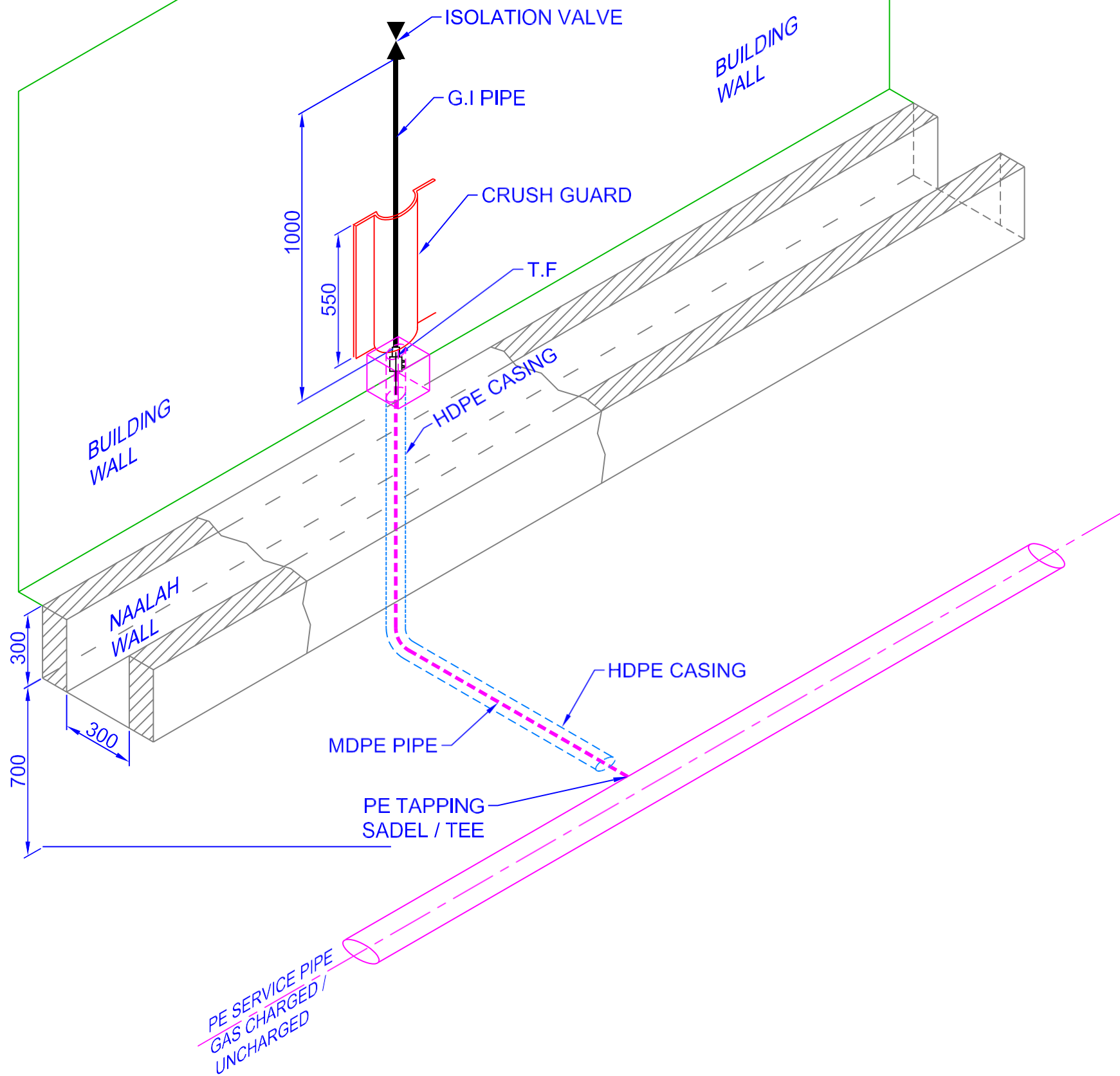

NOTES:-

1. ALL DIMENSIONS ARE IN MM UNLESS NOTED OTHERWISE.

OWNER:



PMC:



M/s. VCS QUALITY SERVICES PVT. LTD.

PROJECT:

**TITLE: DRAIN CROSSING FOR LAYING OF SERVICE LINES
WHERE PEDESTAL IS POSSIBLE**

SCALE N.T.S.	DATE	CAD FILE: DATE	CAD	A3
-----------------	------	-------------------	-----	----

DRG. NO. -10-03-44 REV-0

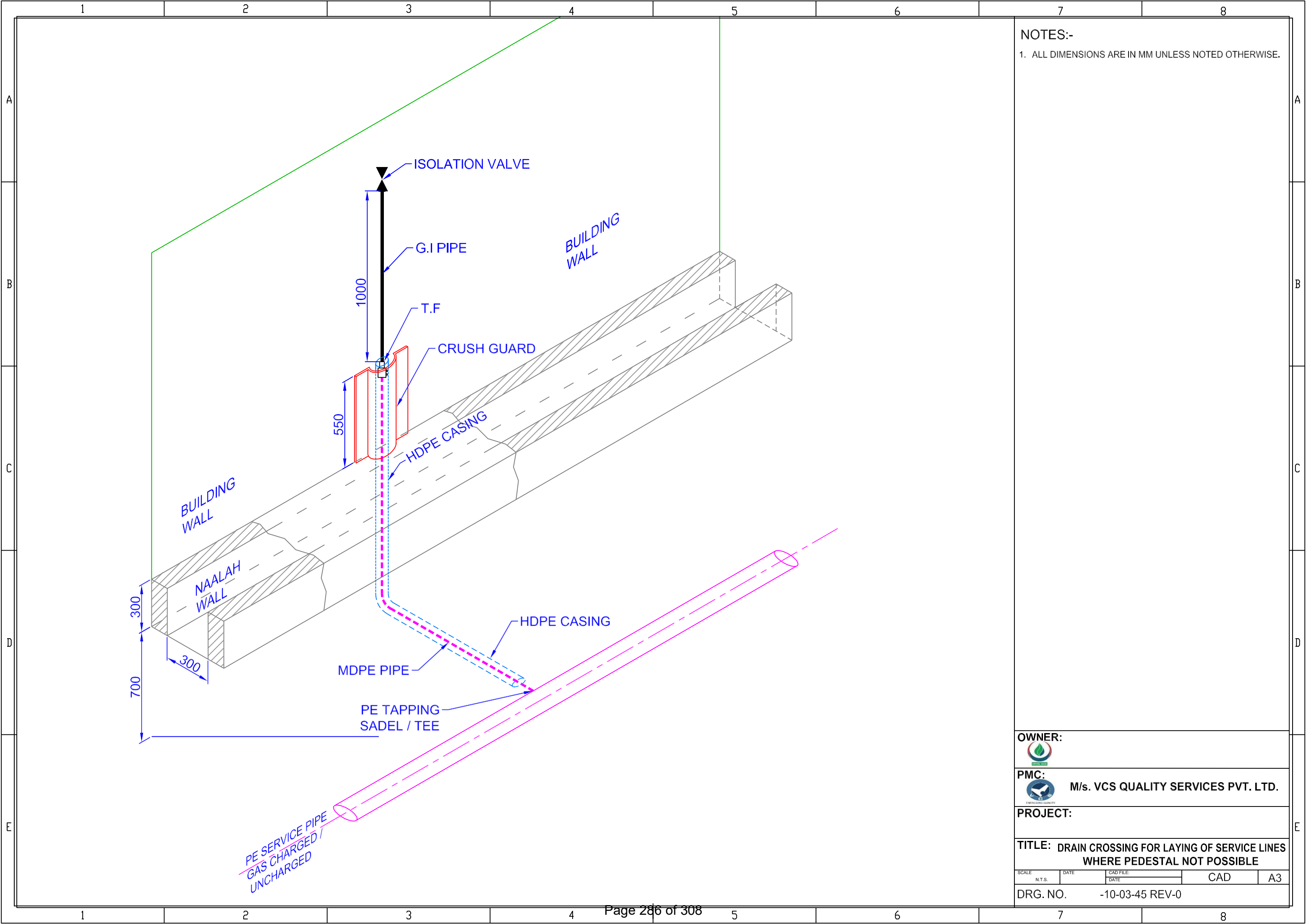

NOTES:-
 1. ALL DIMENSIONS ARE IN MM UNLESS NOTED OTHERWISE.

OWNER:

PMC:  M/s. VCS QUALITY SERVICES PVT. LTD.

PROJECT:



TITLE: DRAIN CROSSING FOR LAYING OF SERVICE LINES
 WHERE PEDESTAL NOT POSSIBLE

SCALE	DATE	CAD FILE:	CAD	A3
N.T.S.		DATE		

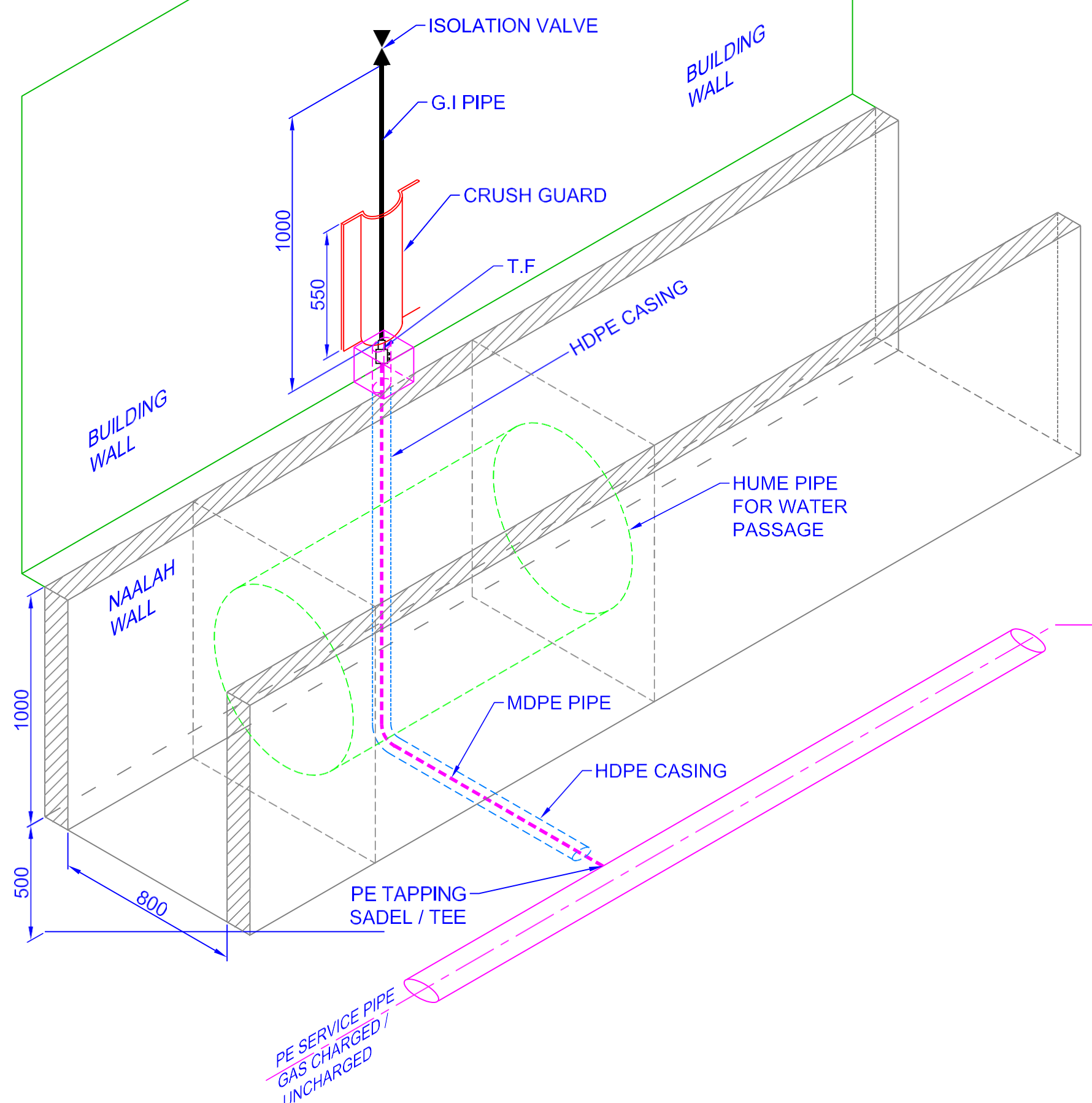
DRG. NO. -10-03-45 REV-0



NOTES:-
 1. ALL DIMENSIONS ARE IN MM UNLESS NOTED OTHERWISE.

OWNER:				
				
PMC:				
 M/s. VCS QUALITY SERVICES PVT. LTD.				
PROJECT:				
TITLE: NALLAH CROSSING FOR LAYING OF SERVICE LINES				
SCALE	DATE	CAD FILE:		
N.T.S.		DATE	CAD	A3
DRG. NO. -10-03-46 REV-0				

- NOTES:-**
1. ALL DIMENSIONS ARE IN MM UNLESS NOTED OTHERWISE.
 2. FOLLOW WRITTEN DIMENSIONS ONLY. DO NOT SCALE THE DRAWINGS.
 3. ROAD / HIGHWAY CROSSING SHALL BE RESTORED TO ORIGINAL CONDITION TO THE ENTIRE SATISFACTION OF OWNER AND CONCERNED AUTHORITIES HAVING JURISDICTION.
 4. REFER API RP 1102 FOR OTHER DESIGN AND INSTALLATION REQUIREMENTS.
 5. ANGLE OF INTERSECTION BETWEEN PIPELINE AND THE ROAD / HIGHWAY SHALL BE AS CLOSE TO 90° AS POSSIBLE BUT IN NO CASE LESS THAN 30°.
 6. CONTRACTOR SHALL VERIFY THE ACTUAL DIMENSION WITH RESPECT TO SURVEY DETAILS OF EACH ROAD / HIGHWAY CROSSING AND PREPARE DETAILED DRAWINGS FOR INDIVIDUAL CROSSING TAKE ENGINEER-IN-CHARGE AND CLIENT'S APPROVAL BEFORE COMMENCEMENT OF CONSTRUCTION.
 7. THE CASING PIPE SHALL BE OF SIZE MAINTAINED AS PER T.S. FOR PE LAYING.

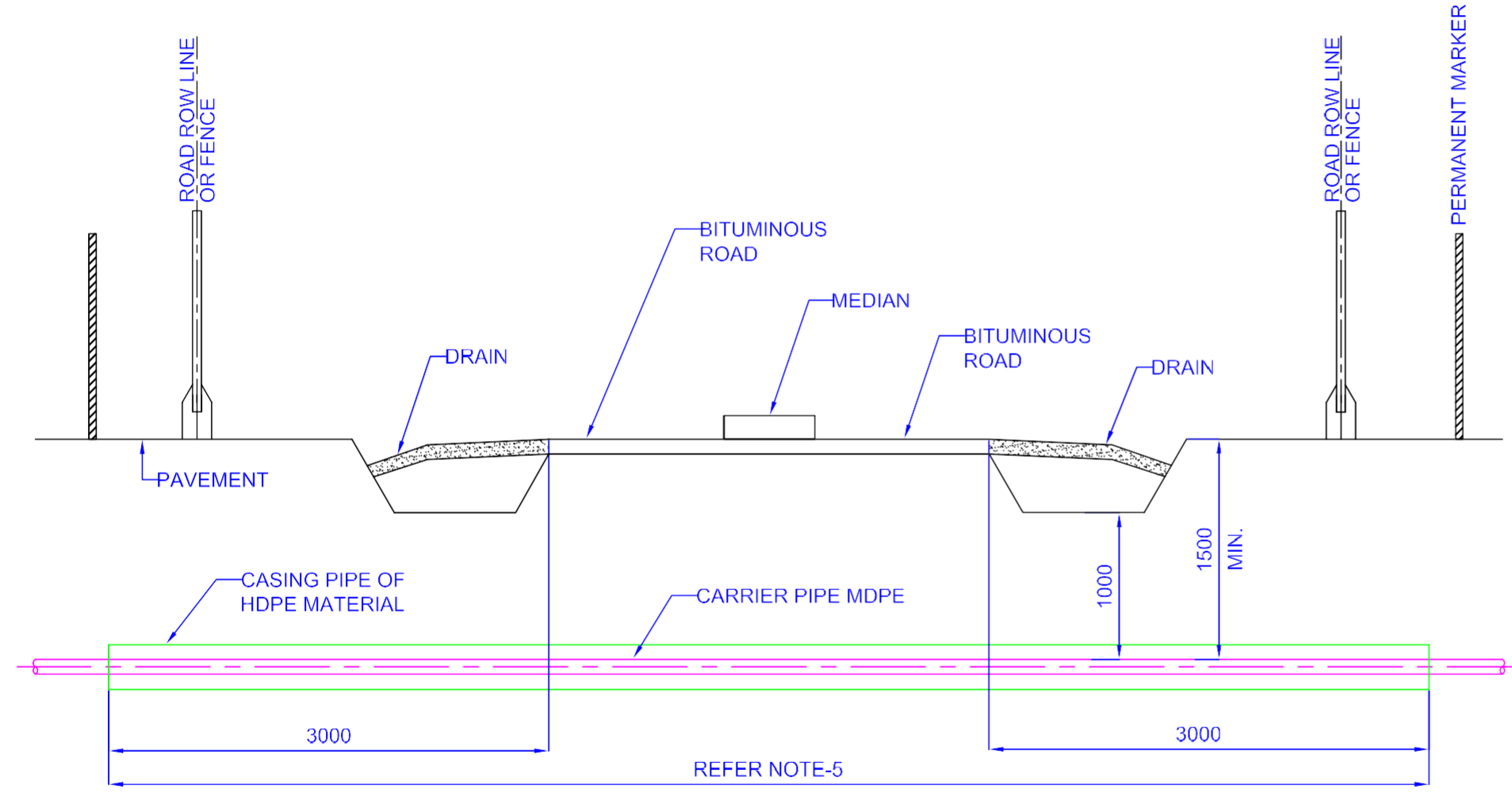

TYPICAL SECTION

OWNER:				
PMC:				
M/s. VCS QUALITY SERVICES PVT. LTD.				
PROJECT:				
TITLE: ROAD / HIGHWAY CASING CROSSING FOR MDPE PIPE				
SCALE: 1:2	DATE:	CAD FILE: DATE:	CAD	A3
DRG. NO. -10-04-23 REV-0				

- NOTES:-**
1. ALL DIMENSIONS ARE IN MM UNLESS NOTED OTHERWISE.
 2. FOLLOW WRITTEN DIMENSIONS ONLY. DO NOT SCALE THE DRAWINGS.
 3. THE SIZES SHOWN IN THE DRAWING ARE TENTATIVE AND SHALL BE DECIDED WHILE DETAIL ENGINEERING.
 4. G.I. INSTALLATION / METER INSTALLATION SHALL BE DECIDED BY OWNER / OWNERS REPRESENTATIVE AS PER SITE CONDITION.

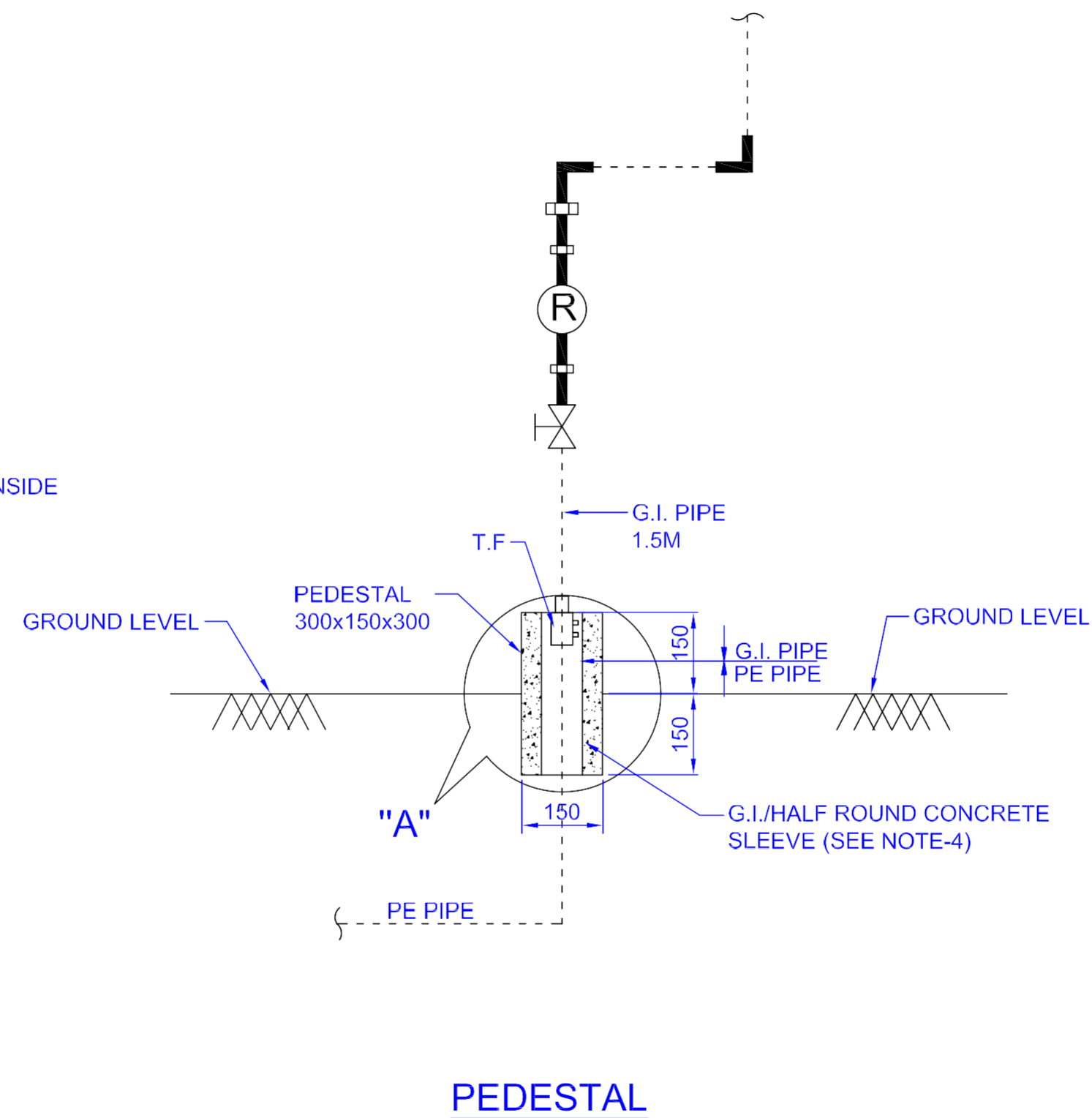
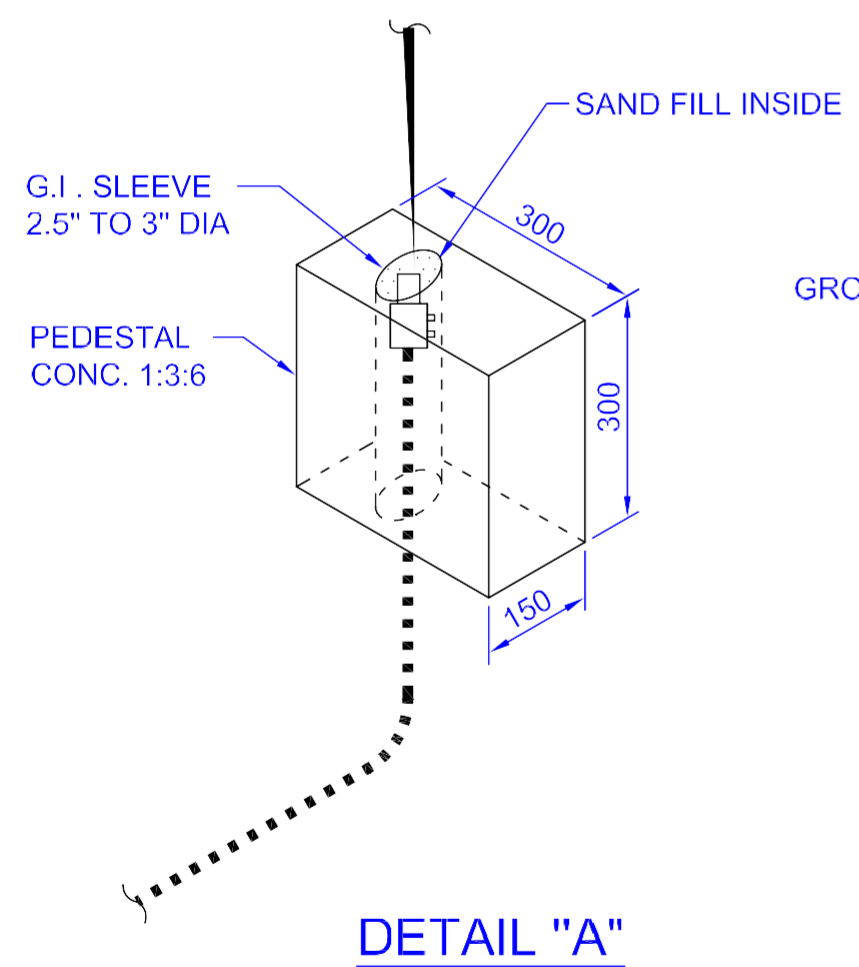

OWNER:				
PMC:				
M/s. VCS QUALITY SERVICES PVT. LTD.				
PROJECT:				
TITLE:				
G.I. PIPE SLEEVE				
SCALE	DATE	CAD FILE	CAD	A3
1:10				
DRG. NO. -20-03-18 REV-0				

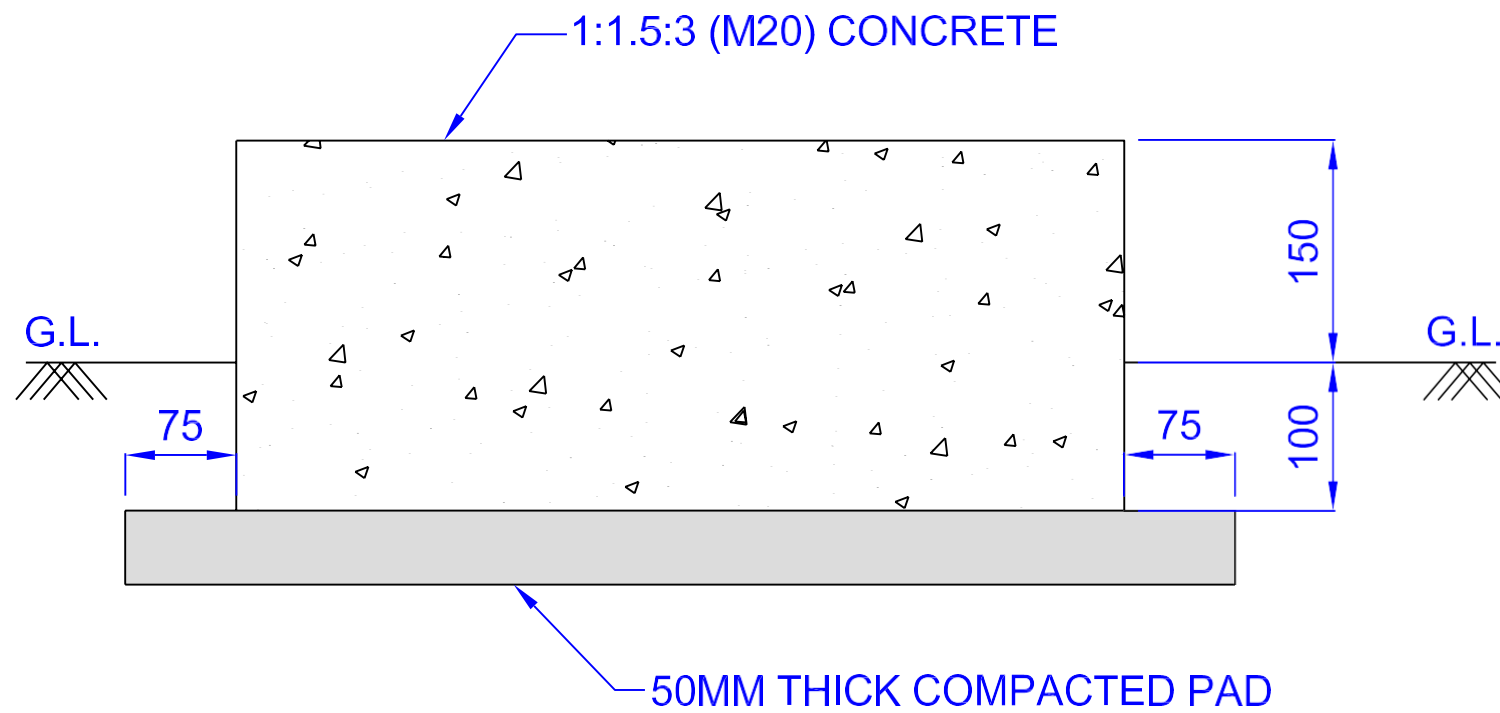
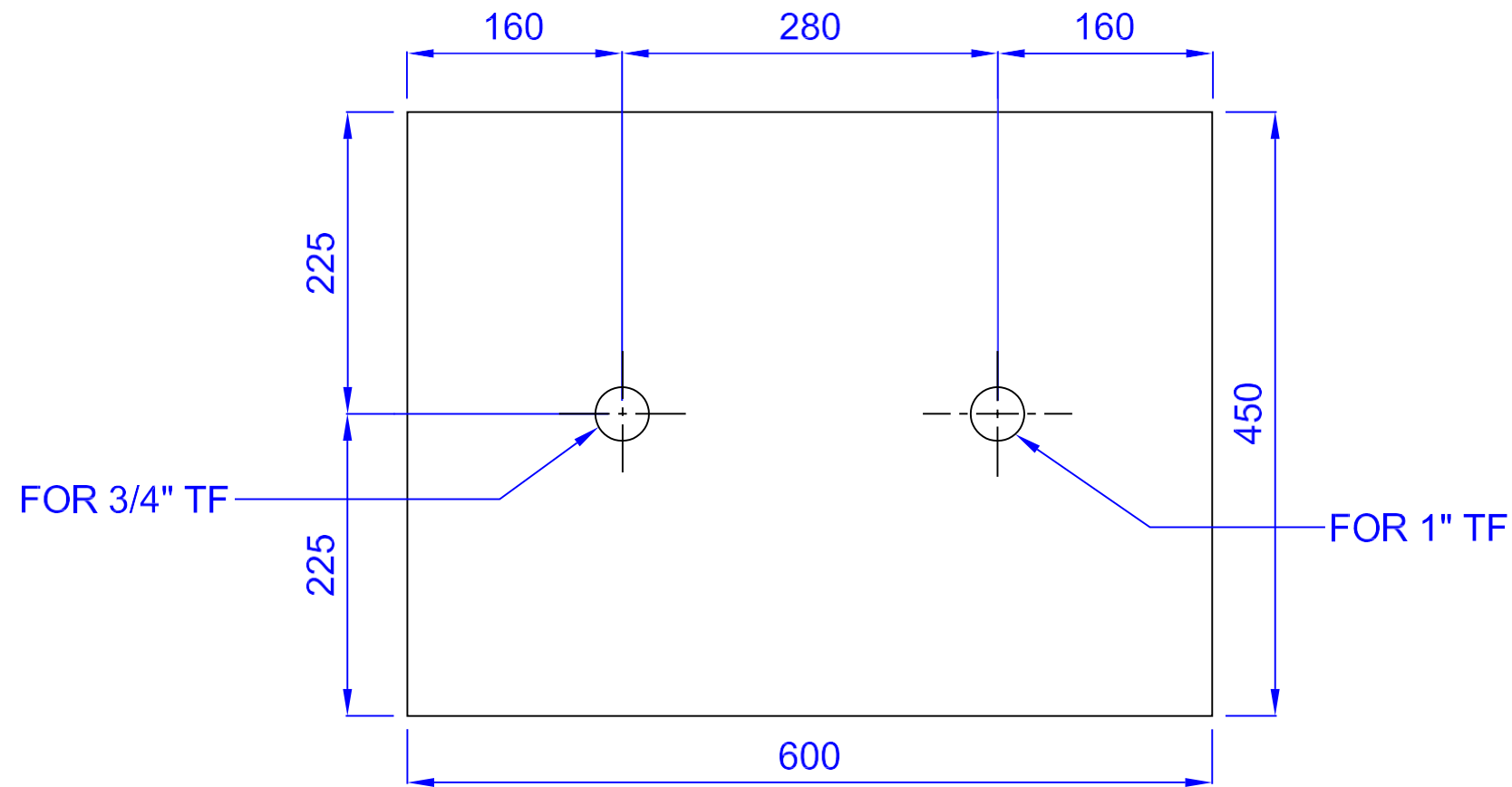

NOTES:-

1. ALL DIMENSIONS ARE IN MM UNLESS NOTED OTHERWISE.
2. FOLLOW WRITTEN DIMENSIONS ONLY. DO NOT SCALE THE DRAWING.

OWNER:



M/s. VCS QUALITY SERVICES PVT. LTD.

PROJECT:

TITLE: SCHEMATIC DIAGRAM OF FOUNDATION FOR SINGLE STREAM SERVICE REGULATOR

SCALE 1:5	DATE	CAD FILE: DATE	CAD	A3
--------------	------	-------------------	-----	----

DRG. NO. -20-03-39 REV-0

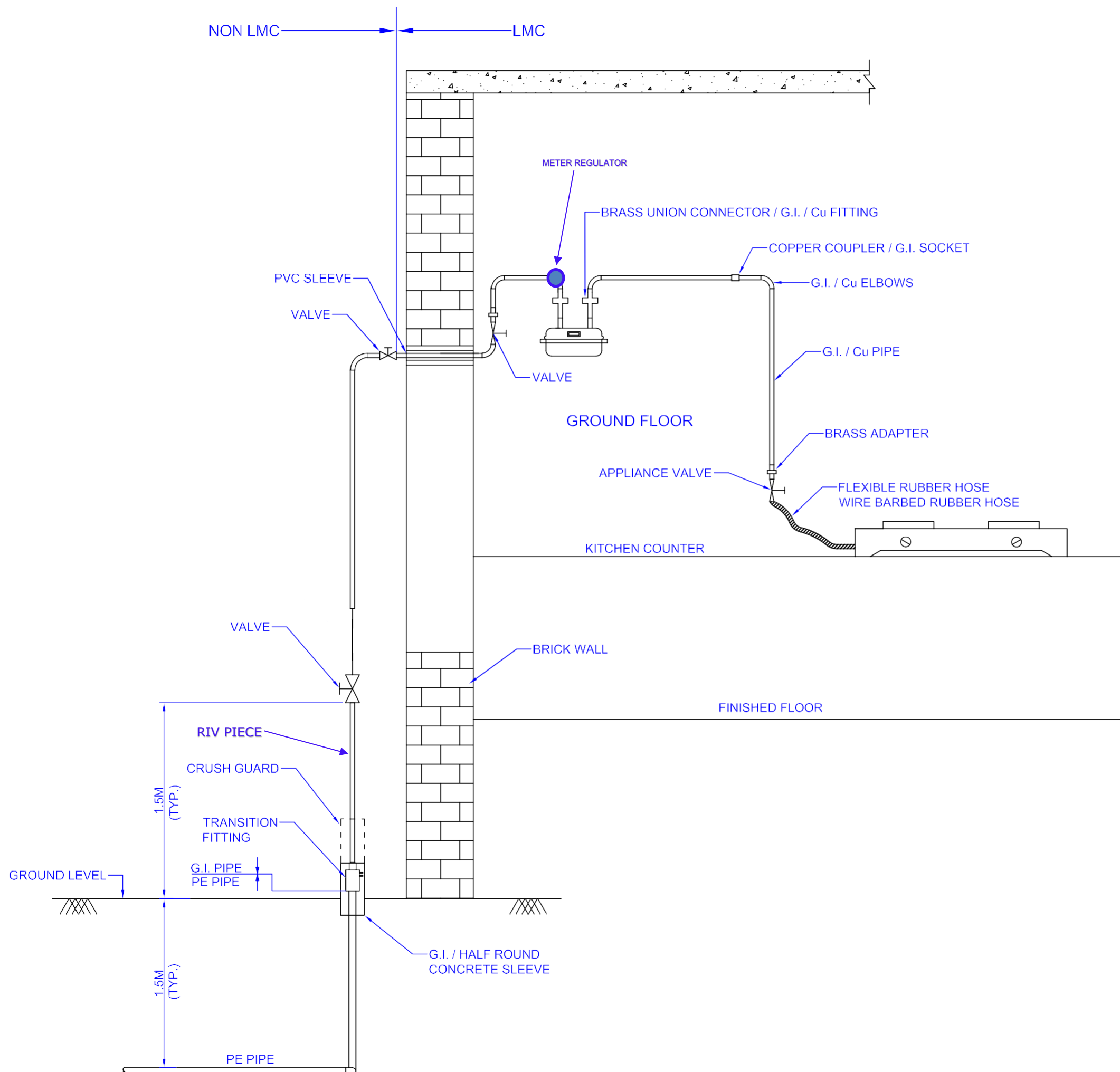

NOTES:-

1. ALL DIMENSIONS ARE IN MM UNLESS NOTED OTHERWISE.
2. THE SIZES SHOWN IN THE DRAWING ARE TENTATIVE AND SHALL BE DECIDED AT THE TIME OF DETAIL ENGINEERING.
3. PIPING DOWNSTREAM METER SHALL BE COPPER IN CASE METER IS INSTALLED WITHIN THE KITCHEN.
4. TENTATIVE RISER LENGTH (FROM OUTLET OF TRANSITION FITTING TO INLET OF ISOLATION VALVE) SHALL BE 1.5M. ANY CHANGES IN RISER LENGTH SHALL BE AFTER APPROVAL FROM EIC.
5. G.I. INSTALLATION / METER INSTALLATION SHALL BE DECIDED BY OWNER / OWNER'S REPRESENTATIVE AS PER SITE CONDITIONS.
6. IF COPPER PIPE GOES TO THE APPLIANCE VALVE THEN BRASS FITTING SHALL BE USED AT THE OUTLET OF METER OR IF G.I. PIPE GOES TO THE APPLIANCE VALVE THEN G.I. FITTING SHALL BE USED AT THE OUTLET OF THE METER.
7. MAXIMUM DISTANCE BETWEEN CLAMPS SHALL BE 1.5M WHEN PIPE GOES IN THE STRAIGHT LENGTH, IF ANY TEE OR ANY FITTING IS USED IN BETWEEN THE PIPE THEN CLAMP SHALL BE PLACED 150 MM AWAY FROM CENTER LINE OF THE FITTING AT EVERY SIDE. HOWEVER, THE SAME MAY BE CHANGED AS PER SITE CONDITIONS / AS DIRECTED BY EIC.
8. TAPPING SHALL BE LEFT NEAR OUTSIDE THE KITCHEN AS DIRECTED BY OWNER / OWNER'S REPRESENTATIVE..

THIS IS THE GENERAL LAYOUT.
FOR LMC AND NON-LMC

OWNER:



PMC:



M/s. VCS QUALITY SERVICES PVT. LTD.

PROJECT:

**TITLE: TYPICAL DOMESTIC CONNECTION LAYOUT
OF NG DISTRIBUTION (NON LMC & LMC)**

SCALE	DATE	CAD FILE	CAD	A3
-------	------	----------	-----	----

DRG. NO. -20-05-01 REV-0

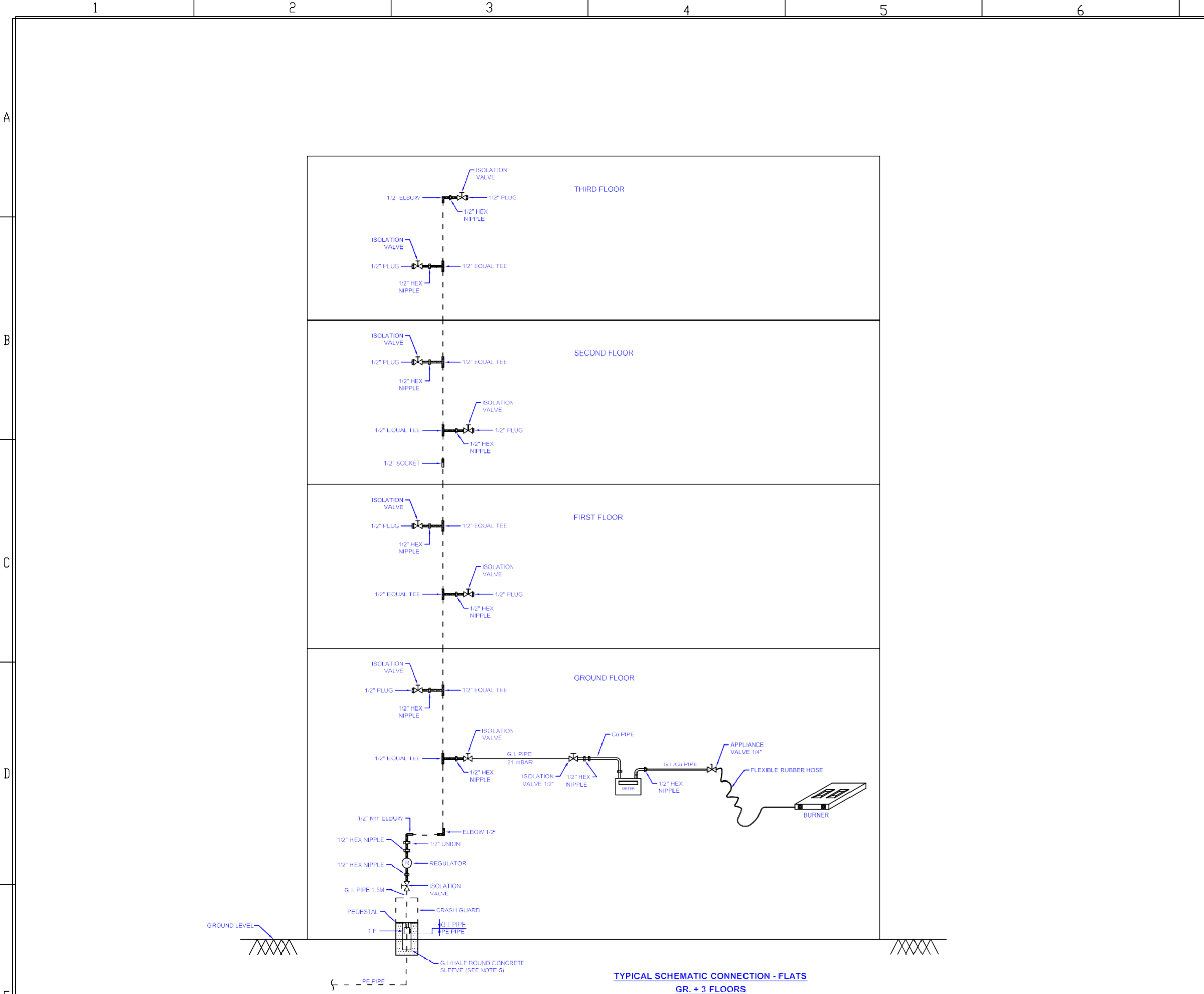

TYPICAL SCHEMATIC CONNECTION - FLATS
GR. + 3 FLOORS

NOTES:-

1. ALL DIMENSIONS ARE IN MM UNLESS NOTED OTHERWISE.
2. THE SIZES SHOWN IN THE DRAWING ARE TENTATIVE AND SHALL BE DECIDED AT THE TIME OF DETAIL ENGINEERING.
3. PIPING DOWNSTREAM METER SHALL BE COPPER IN CASE METER IS INSTALLED WITHIN THE KITCHEN.
4. TENTATIVE RISER LENGTH (FROM OUTLET OF TRANSITION FITTING TO INLET OF ISOLATION VALVE) SHALL BE 1.5M. ANY CHANGES IN RISER LENGTH SHALL BE AFTER APPROVAL FROM EIC.
5. G.I. INSTALLATION / METER INSTALLATION SHALL BE DECIDED BY OWNER / OWNER'S REPRESENTATIVE AS PER SITE CONDITIONS.
6. IF COPPER PIPE GOES TO THE APPLIANCE VALVE THEN BRASS FITTING SHALL BE USED AT THE OUTLET OF METER OR IF G.I. PIPE GOES TO THE APPLIANCE VALVE THEN G.I. FITTING SHALL BE USED AT THE OUTLET OF THE METER.
7. MAXIMUM DISTANCE BETWEEN CLAMPS SHALL BE 1.5M WHEN PIPE GOES IN THE STRAIGHT LENGTH, IF ANY TEE OR ANY FITTING IS USED IN BETWEEN THE PIPE THEN CLAMP SHALL BE PLACED 150 MM AWAY FROM CENTER LINE OF THE FITTING AT EVERY SIDE. HOWEVER, THE SAME MAY BE CHANGED AS PER SITE CONDITIONS / AS DIRECTED BY EIC.
8. METER CLAMP SHALL BE APPROVED FROM OWNER / OWNER'S REPRESENTATIVE..

OWNER:



PMC: M/s. VCS QUALITY SERVICES PVT. LTD.

PROJECT:

TITLE: TYPICAL SCHEMATIC CONNECTION - FLATS
GR. + 3 FLOORS

SCALE	DATE	CAD FILE	CAD	A3
-------	------	----------	-----	----

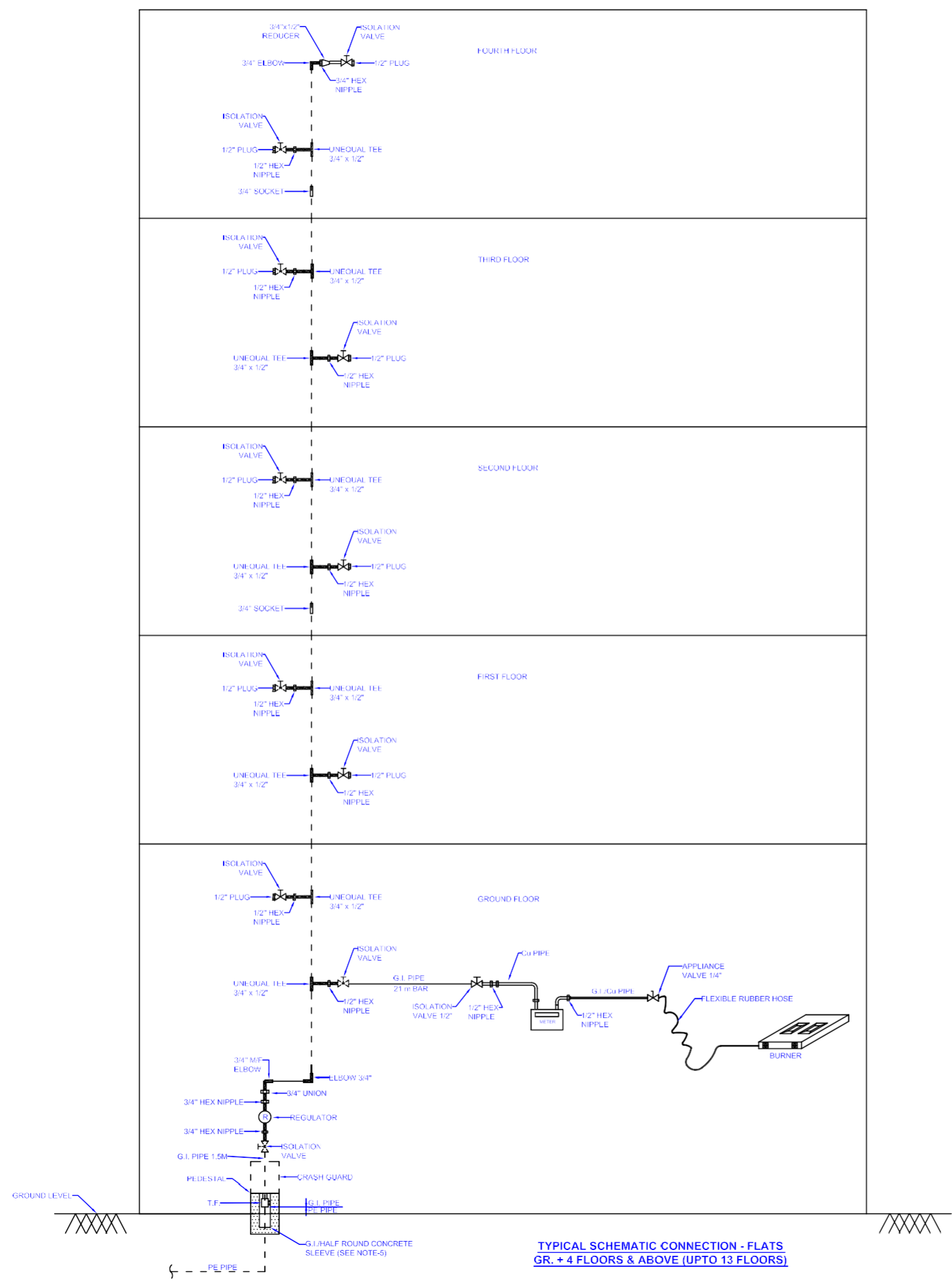

DRG. NO. -20-05-02 REV-0



TYPICAL SCHEMATIC CONNECTION - FLATS
GR. + 4 FLOORS & ABOVE (UPTO 13 FLOORS)

NOTES:-

1. ALL DIMENSIONS ARE IN MM UNLESS NOTED OTHERWISE.
2. THE SIZES SHOWN IN THE DRAWING ARE TENTATIVE AND SHALL BE DECIDED AT THE TIME OF DETAIL ENGINEERING.
3. PIPING DOWNSTREAM METER SHALL BE COPPER IN CASE METER IS INSTALLED WITHIN THE KITCHEN.
4. TENTATIVE RISER LENGTH (FROM OUTLET OF TRANSITION FITTING TO INLET OF ISOLATION VALVE) SHALL BE 1.5M. ANY CHANGES IN RISER LENGTH SHALL BE AFTER APPROVAL FROM EIC.
5. G.I. INSTALLATION / METER INSTALLATION SHALL BE DECIDED BY OWNER / OWNER'S REPRESENTATIVE AS PER SITE CONDITIONS.
6. IF COPPER PIPE GOES TO THE APPLIANCE VALVE THEN BRASS FITTING SHALL BE USED AT THE OUTLET OF METER OR IF G.I. PIPE GOES TO THE APPLIANCE VALVE THEN G.I. FITTING SHALL BE USED AT THE OUTLET OF THE METER.
7. MAXIMUM DISTANCE BETWEEN CLAMPS SHALL BE 1.5M WHEN PIPE GOES IN THE STRAIGHT LENGTH, IF ANY TEE OR ANY FITTING IS USED IN BETWEEN THE PIPE THEN CLAMP SHALL BE PLACED 150 MM AWAY FROM CENTER LINE OF THE FITTING AT EVERY SIDE. HOWEVER, THE SAME MAY BE CHANGED AS PER SITE CONDITIONS / AS DIRECTED BY EIC.
8. METER CLAMP SHALL BE APPROVED FROM OWNER / OWNER'S REPRESENTATIVE..

OWNER:

PMC:
 **M/s. VCS QUALITY SERVICES PVT. LTD.**
PROJECT:
TITLE: TYPICAL SCHEMATIC CONNECTION - FLATS GR. + 4 FLOORS & ABOVE (UPTO 13 FLOORS)

SCALE	DATE	CAD FILE	CAD	A3

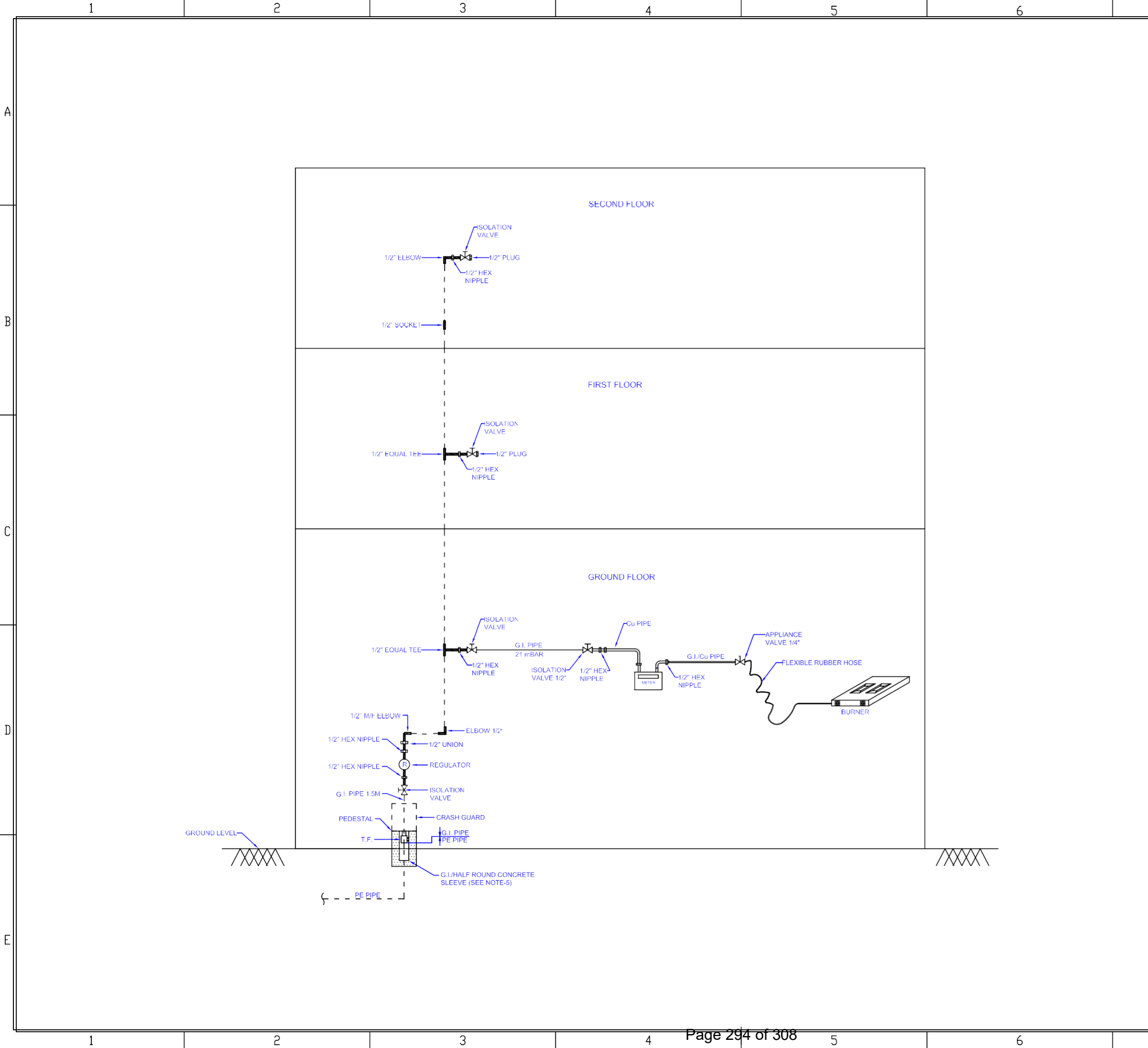
DRG. NO. -20-05-03 REV-0



- NOTES:-**
1. ALL DIMENSIONS ARE IN MM UNLESS NOTED OTHERWISE.
 2. THE SIZES SHOWN IN THE DRAWING ARE TENTATIVE AND SHALL BE DECIDED AT THE TIME OF DETAIL ENGINEERING.
 3. PIPING DOWNSTREAM METER SHALL BE COPPER IN CASE METER IS INSTALLED WITHIN THE KITCHEN.
 4. TENTATIVE RISER LENGTH (FROM OUTLET OF TRANSITION FITTING TO INLET OF ISOLATION VALVE) SHALL BE 1.5M. ANY CHANGES IN RISER LENGTH SHALL BE AFTER APPROVAL FROM EIC.
 5. G.I. INSTALLATION / METER INSTALLATION SHALL BE DECIDED BY OWNER / OWNER'S REPRESENTATIVE AS PER SITE CONDITIONS.
 6. IF COPPER PIPE GOES TO THE APPLIANCE VALVE THEN BRASS FITTING SHALL BE USED AT THE OUTLET OF METER OR IF G.I. PIPE GOES TO THE APPLIANCE VALVE THEN G.I. FITTING SHALL BE USED AT THE OUTLET OF THE METER.
 7. MAXIMUM DISTANCE BETWEEN CLAMPS SHALL BE 1.5M WHEN PIPE GOES IN THE STRAIGHT LENGTH, IF ANY TEE OR ANY FITTING IS USED IN BETWEEN THE PIPE THEN CLAMP SHALL BE PLACED 150 MM AWAY FROM CENTER LINE OF THE FITTING AT EVERY SIDE. HOWEVER, THE SAME MAY BE CHANGED AS PER SITE CONDITIONS / AS DIRECTED BY EIC.
 8. METER CLAMP SHALL BE APPROVED FROM OWNER / OWNER'S REPRESENTATIVE..

OWNER:

PMC:
 **M/s. VCS QUALITY SERVICES PVT. LTD.**

PROJECT:

TITLE:
TYPICAL SCHEMATIC CONNECTION - KOTHI

SCALE	DATE	CAD FILE	CAD	A3

DRG. NO. -20-05-04 REV-0

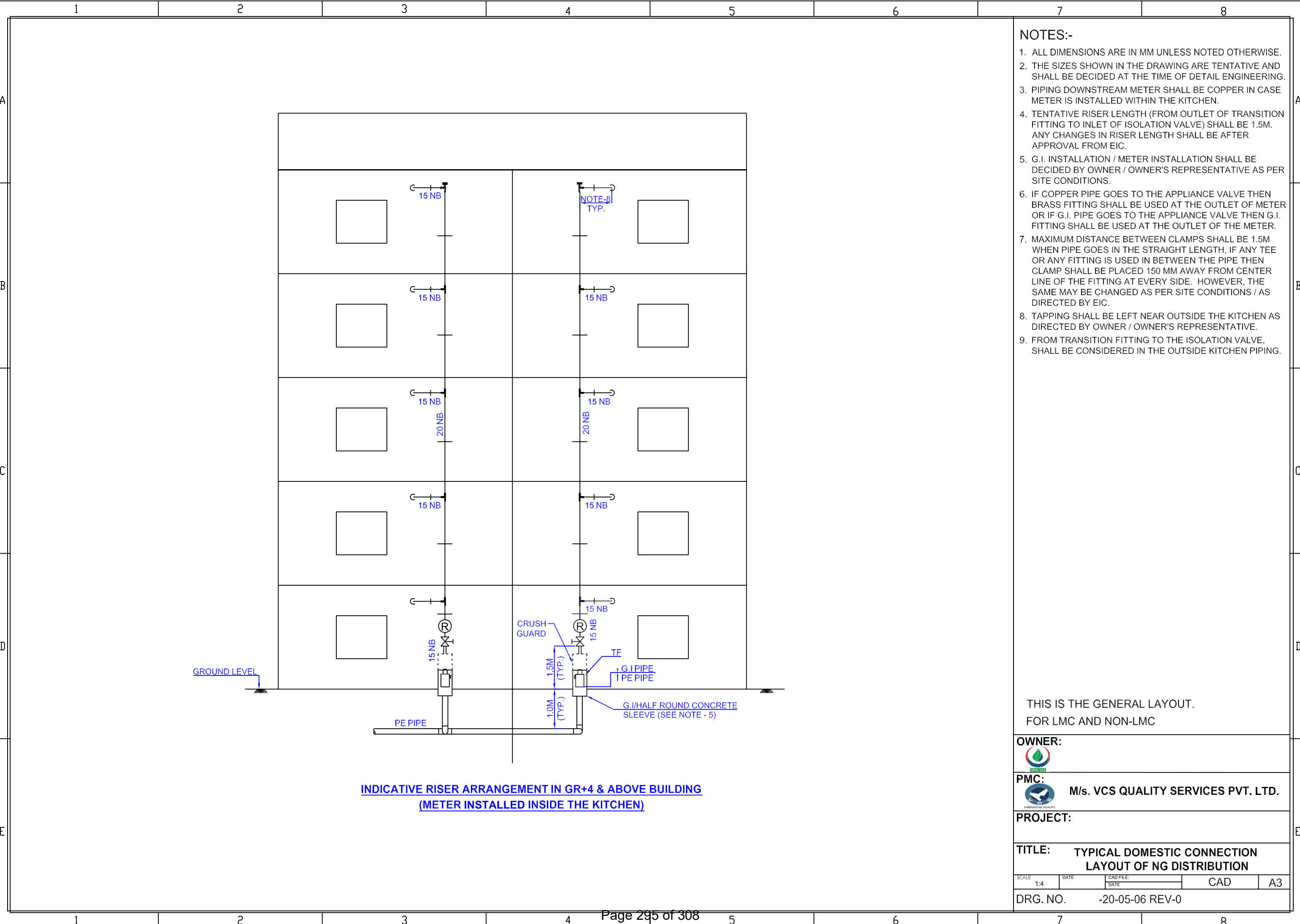

NOTES:-

1. ALL DIMENSIONS ARE IN MM UNLESS NOTED OTHERWISE.
2. THE SIZES SHOWN IN THE DRAWING ARE TENTATIVE AND SHALL BE DECIDED AT THE TIME OF DETAIL ENGINEERING.
3. PIPING DOWNSTREAM METER SHALL BE COPPER IN CASE METER IS INSTALLED WITHIN THE KITCHEN.
4. TENTATIVE RISER LENGTH (FROM OUTLET OF TRANSITION FITTING TO INLET OF ISOLATION VALVE) SHALL BE 1.5M. ANY CHANGES IN RISER LENGTH SHALL BE AFTER APPROVAL FROM EIC.
5. G.I. INSTALLATION / METER INSTALLATION SHALL BE DECIDED BY OWNER / OWNER'S REPRESENTATIVE AS PER SITE CONDITIONS.
6. IF COPPER PIPE GOES TO THE APPLIANCE VALVE THEN BRASS FITTING SHALL BE USED AT THE OUTLET OF METER OR IF G.I. PIPE GOES TO THE APPLIANCE VALVE THEN G.I. FITTING SHALL BE USED AT THE OUTLET OF THE METER.
7. MAXIMUM DISTANCE BETWEEN CLAMPS SHALL BE 1.5M WHEN PIPE GOES IN THE STRAIGHT LENGTH, IF ANY TEE OR ANY FITTING IS USED IN BETWEEN THE PIPE THEN CLAMP SHALL BE PLACED 150 MM AWAY FROM CENTER LINE OF THE FITTING AT EVERY SIDE. HOWEVER, THE SAME MAY BE CHANGED AS PER SITE CONDITIONS / AS DIRECTED BY EIC.
8. TAPPING SHALL BE LEFT NEAR OUTSIDE THE KITCHEN AS DIRECTED BY OWNER / OWNER'S REPRESENTATIVE.
9. FROM TRANSITION FITTING TO THE ISOLATION VALVE, SHALL BE CONSIDERED IN THE OUTSIDE KITCHEN PIPING.

THIS IS THE GENERAL LAYOUT.
FOR LMC AND NON-LMC

OWNER:			
PMC:			
M/s. VCS QUALITY SERVICES PVT. LTD.			
PROJECT:			
TITLE: TYPICAL DOMESTIC CONNECTION LAYOUT OF NG DISTRIBUTION			
SCALE 1:4	DATE	CAD FILE: DATE	CAD A3
DRG. NO.		-20-05-06 REV-0	

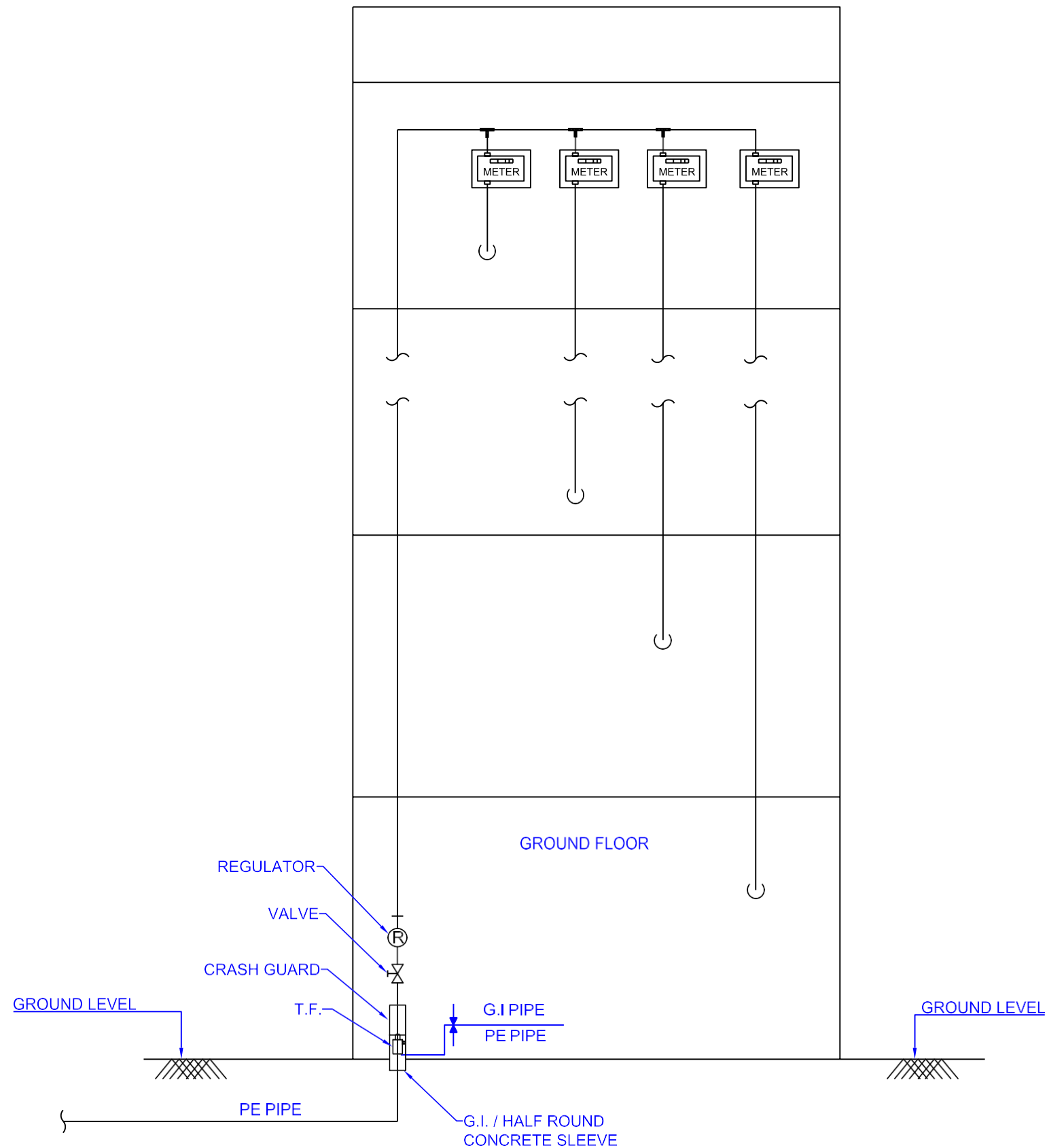

INDICATIVE RISER ARRANGEMENT IN BUILDING,
IF METER IS INSTALLED AT TOP OF FLOOR

NOTES:-

1. ALL DIMENSIONS ARE IN MM UNLESS NOTED OTHERWISE.
2. THE SIZES SHOWN IN THE DRAWING ARE TENTATIVE AND SHALL BE DECIDED AT THE TIME OF DETAIL ENGINEERING.
3. PIPING DOWNSTREAM METER SHALL BE COPPER IN CASE METER IS INSTALLED WITHIN THE KITCHEN.
4. TENTATIVE RISER LENGTH (FROM OUTLET OF TRANSITION FITTING TO INLET OF ISOLATION VALVE) SHALL BE 1.5M. ANY CHANGES IN RISER LENGTH SHALL BE AFTER APPROVAL FROM EIC.
5. G.I. INSTALLATION / METER INSTALLATION SHALL BE DECIDED BY OWNER / OWNER'S REPRESENTATIVE AS PER SITE CONDITIONS.
6. IF COPPER PIPE GOES TO THE APPLIANCE VALVE THEN BRASS FITTING SHALL BE USED AT THE OUTLET OF METER OR IF G.I. PIPE GOES TO THE APPLIANCE VALVE THEN G.I. FITTING SHALL BE USED AT THE OUTLET OF THE METER.
7. MAXIMUM DISTANCE BETWEEN CLAMPS SHALL BE 1.5M WHEN PIPE GOES IN THE STRAIGHT LENGTH, IF ANY TEE OR ANY FITTING IS USED IN BETWEEN THE PIPE THEN CLAMP SHALL BE PLACED 150 MM AWAY FROM CENTER LINE OF THE FITTING AT EVERY SIDE. HOWEVER, THE SAME MAY BE CHANGED AS PER SITE CONDITIONS / AS DIRECTED BY EIC.
8. TAPPING SHALL BE LEFT NEAR OUTSIDE THE KITCHEN AS DIRECTED BY OWNER / OWNER'S REPRESENTATIVE.
9. FROM TRANSITION FITTING TO THE ISOLATION VALVE, SHALL BE CONSIDERED IN THE OUTSIDE KITCHEN PIPING.
10. AT THE TIME OF MEASURING LENGTH OF G.I./COPPER PIPE, G.I./COPPER FITTINGS SHALL BE COUNTED IN THE PIPE LENGTH.

THIS IS THE GENERAL LAYOUT.

OWNER:



PMC:



M/s. VCS QUALITY SERVICES PVT. LTD.

PROJECT:

**TITLE: TYPICAL DOMESTIC CONNECTION
LAYOUT OF NG DISTRIBUTION**

SCALE N.T.S.	DATE	CAD FILE: DATE	CAD	A3
-----------------	------	-------------------	-----	----

DRG. NO. -20-05-07 REV-0

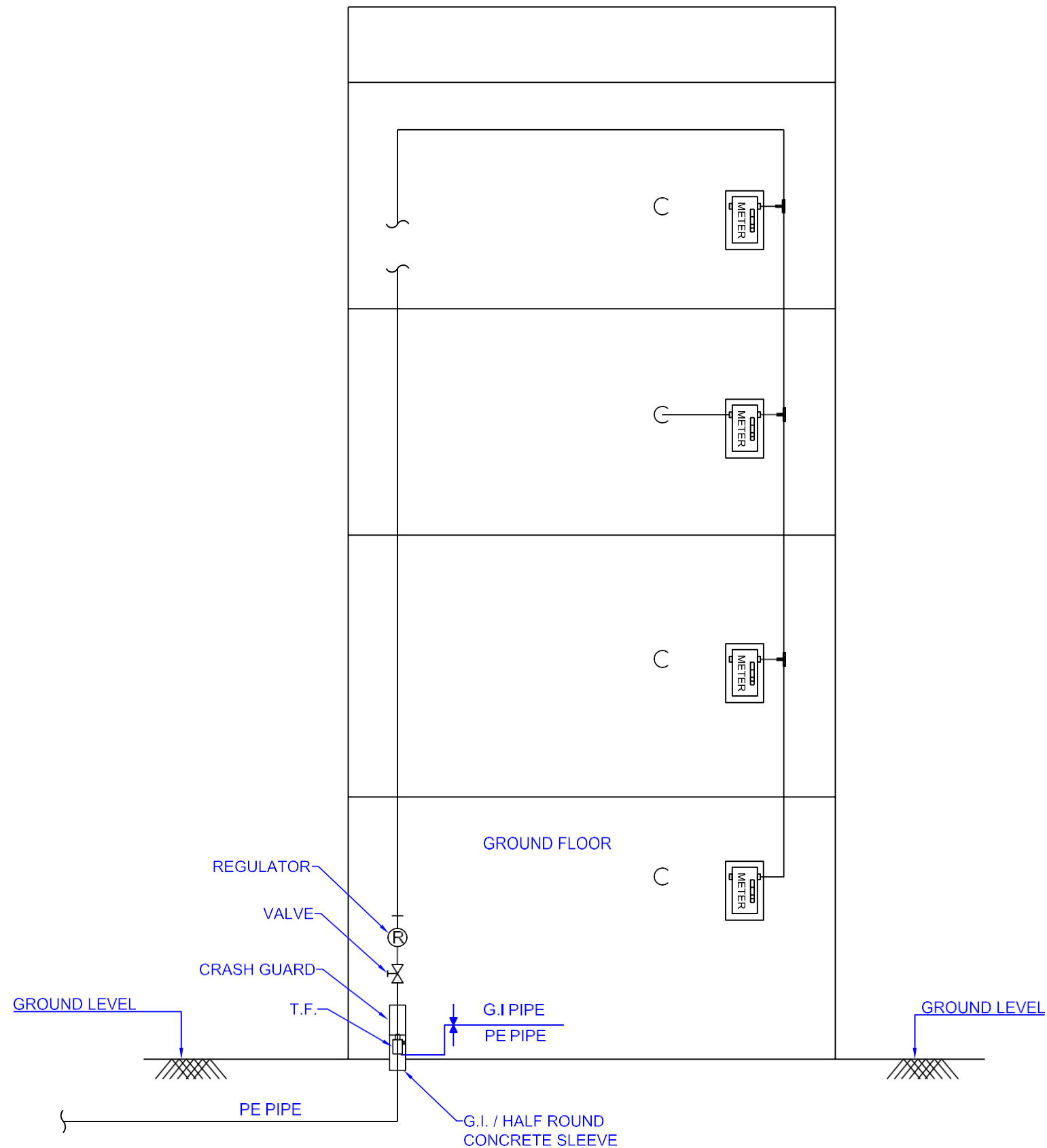

INDICATIVE RISER ARRANGEMENT IN BUILDING,
IF METER IS INSTALLED AT EACH FLOOR

NOTES:-

1. ALL DIMENSIONS ARE IN MM UNLESS NOTED OTHERWISE.
2. THE SIZES SHOWN IN THE DRAWING ARE TENTATIVE AND SHALL BE DECIDED AT THE TIME OF DETAIL ENGINEERING.
3. PIPING DOWNSTREAM METER SHALL BE COPPER IN CASE METER IS INSTALLED WITHIN THE KITCHEN.
4. TENTATIVE RISER LENGTH (FROM OUTLET OF TRANSITION FITTING TO INLET OF ISOLATION VALVE) SHALL BE 1.5M. ANY CHANGES IN RISER LENGTH SHALL BE AFTER APPROVAL FROM EIC.
5. G.I. INSTALLATION / METER INSTALLATION SHALL BE DECIDED BY OWNER / OWNER'S REPRESENTATIVE AS PER SITE CONDITIONS.
6. IF COPPER PIPE GOES TO THE APPLIANCE VALVE THEN BRASS FITTING SHALL BE USED AT THE OUTLET OF METER OR IF G.I. PIPE GOES TO THE APPLIANCE VALVE THEN G.I. FITTING SHALL BE USED AT THE OUTLET OF THE METER.
7. MAXIMUM DISTANCE BETWEEN CLAMPS SHALL BE 1.5M WHEN PIPE GOES IN THE STRAIGHT LENGTH, IF ANY TEE OR ANY FITTING IS USED IN BETWEEN THE PIPE THEN CLAMP SHALL BE PLACED 150 MM AWAY FROM CENTER LINE OF THE FITTING AT EVERY SIDE. HOWEVER, THE SAME MAY BE CHANGED AS PER SITE CONDITIONS / AS DIRECTED BY EIC.
8. TAPPING SHALL BE LEFT NEAR OUTSIDE THE KITCHEN AS DIRECTED BY OWNER / OWNER'S REPRESENTATIVE.
9. FROM TRANSITION FITTING TO THE ISOLATION VALVE, SHALL BE CONSIDERED IN THE OUTSIDE KITCHEN PIPING.
10. AT THE TIME OF MEASURING LENGTH OF G.I./COPPER PIPE, G.I./COPPER FITTINGS SHALL BE COUNTED IN THE PIPE LENGTH.

THIS IS THE GENERAL LAYOUT.

OWNER:



PMC:



M/s. VCS QUALITY SERVICES PVT. LTD.

PROJECT:

**TITLE: TYPICAL DOMESTIC CONNECTION
LAYOUT OF NG DISTRIBUTION**

SCALE N.T.S.	DATE	CAD FILE: DATE	CAD	A3
-----------------	------	-------------------	-----	----

DRG. NO. -20-05-08 REV-0

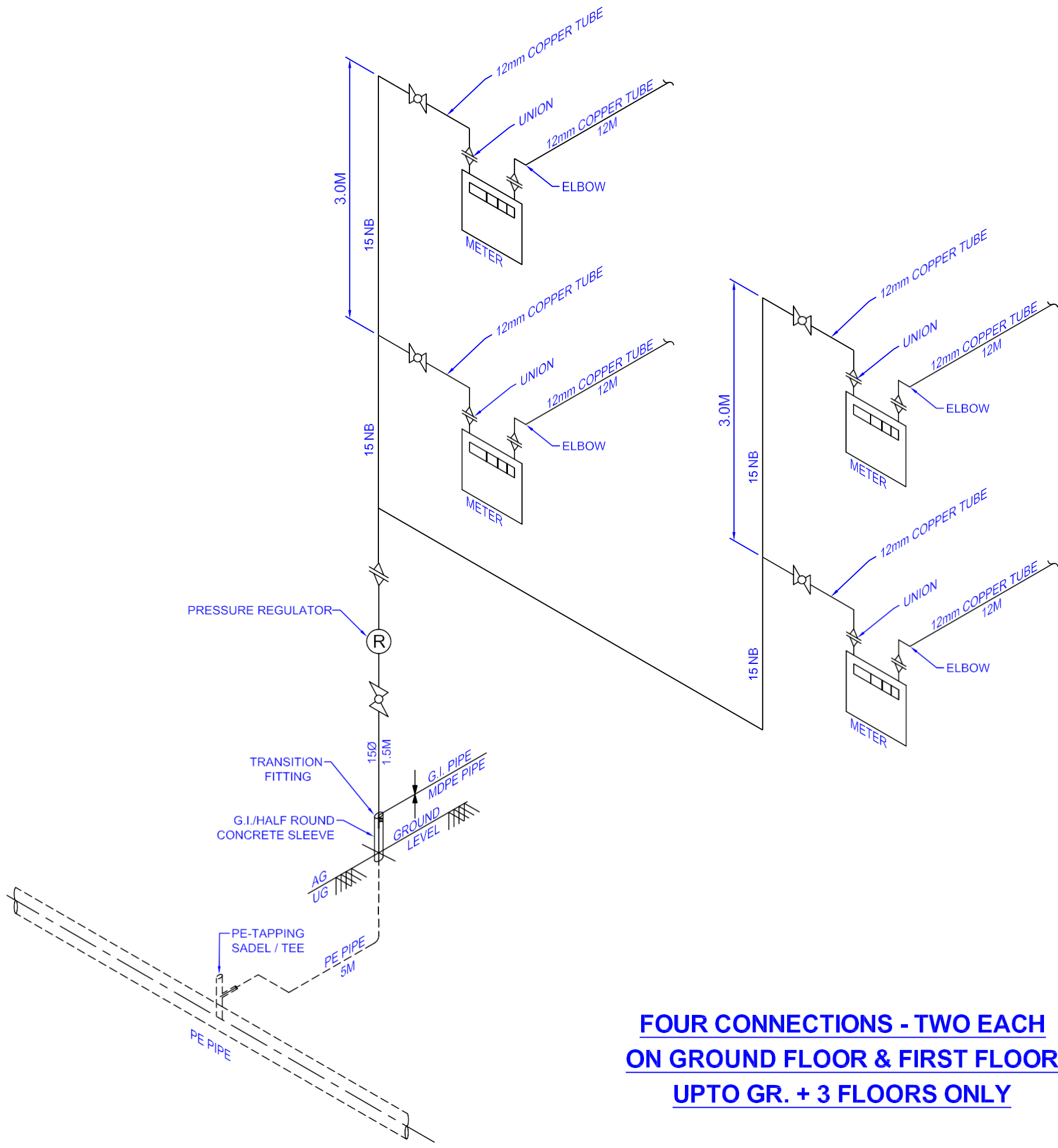

**FOUR CONNECTIONS - TWO EACH
ON GROUND FLOOR & FIRST FLOOR
UPTO GR. + 3 FLOORS ONLY**

NOTES:-

1. ALL DIMENSIONS ARE IN MM UNLESS NOTED OTHERWISE.
2. THE SIZES SHOWN IN THE DRAWING ARE TENTATIVE AND SHALL BE DECIDED AT THE TIME OF DETAIL ENGINEERING.
3. PIPING DOWNSTREAM METER SHALL BE COPPER IN CASE METER IS INSTALLED WITHIN THE KITCHEN.
4. TENTATIVE RISER LENGTH (FROM OUTLET OF TRANSITION FITTING TO INLET OF ISOLATION VALVE) SHALL BE 1.5M. ANY CHANGES IN RISER LENGTH SHALL BE AFTER APPROVAL FROM EIC.
5. G.I. INSTALLATION / METER INSTALLATION SHALL BE DECIDED BY OWNER / OWNER'S REPRESENTATIVE AS PER SITE CONDITIONS.
6. IF COPPER PIPE GOES TO THE APPLIANCE VALVE THEN BRASS FITTING SHALL BE USED AT THE OUTLET OF METER OR IF G.I. PIPE GOES TO THE APPLIANCE VALVE THEN G.I. FITTING SHALL BE USED AT THE OUTLET OF THE METER.
7. MAXIMUM DISTANCE BETWEEN CLAMPS SHALL BE 1.5M WHEN PIPE GOES IN THE STRAIGHT LENGTH, IF ANY TEE OR ANY FITTING IS USED IN BETWEEN THE PIPE THEN CLAMP SHALL BE PLACED 150 MM AWAY FROM CENTER LINE OF THE FITTING AT EVERY SIDE. HOWEVER, THE SAME MAY BE CHANGED AS PER SITE CONDITIONS / AS DIRECTED BY EIC.

THIS IS THE GENERAL LAYOUT.
FOR LMC AND NON-LMC

OWNER:			
PMC:			
M/s. VCS QUALITY SERVICES PVT. LTD.			
PROJECT:			
TITLE: TYPICAL DOMESTIC CONNECTION LAYOUT OF NG DISTRIBUTION			
SCALE	DATE	CAD FILE:	
N.T.S.		DATE	CAD A3
DRG. NO.		-20-05-10 REV-0	

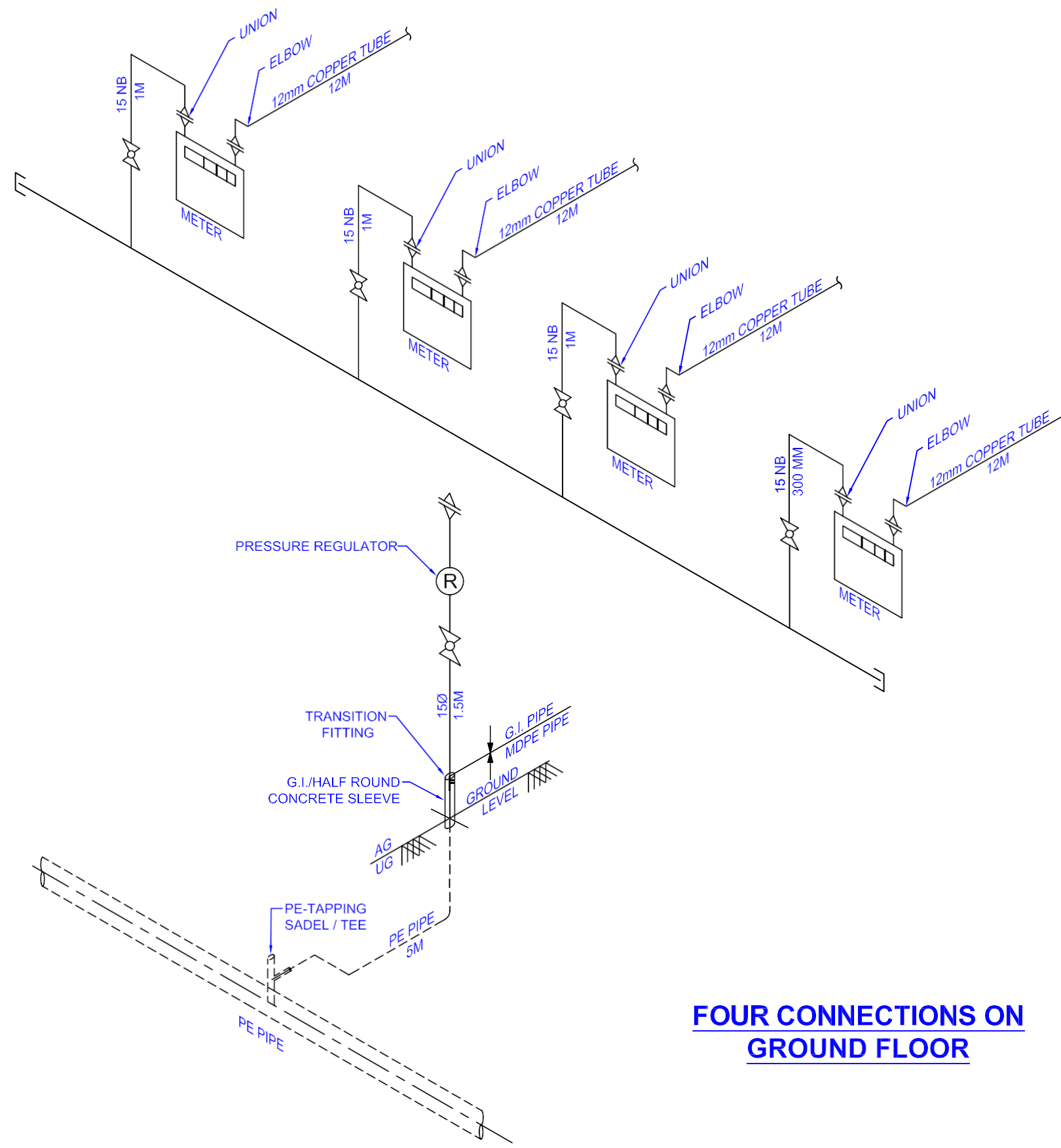

FOUR CONNECTIONS ON GROUND FLOOR

NOTES:-

1. ALL DIMENSIONS ARE IN MM UNLESS NOTED OTHERWISE.
2. THE SIZES SHOWN IN THE DRAWING ARE TENTATIVE AND SHALL BE DECIDED AT THE TIME OF DETAIL ENGINEERING.
3. PIPING DOWNSTREAM METER SHALL BE COPPER IN CASE METER IS INSTALLED WITHIN THE KITCHEN.
4. TENTATIVE RISER LENGTH (FROM OUTLET OF TRANSITION FITTING TO INLET OF ISOLATION VALVE) SHALL BE 1.5M. ANY CHANGES IN RISER LENGTH SHALL BE AFTER APPROVAL FROM EIC.
5. G.I. INSTALLATION / METER INSTALLATION SHALL BE DECIDED BY OWNER / OWNER'S REPRESENTATIVE AS PER SITE CONDITIONS.
6. IF COPPER PIPE GOES TO THE APPLIANCE VALVE THEN BRASS FITTING SHALL BE USED AT THE OUTLET OF METER OR IF G.I. PIPE GOES TO THE APPLIANCE VALVE THEN G.I. FITTING SHALL BE USED AT THE OUTLET OF THE METER.
7. MAXIMUM DISTANCE BETWEEN CLAMPS SHALL BE 1.5M WHEN PIPE GOES IN THE STRAIGHT LENGTH, IF ANY TEE OR ANY FITTING IS USED IN BETWEEN THE PIPE THEN CLAMP SHALL BE PLACED 150 MM AWAY FROM CENTER LINE OF THE FITTING AT EVERY SIDE. HOWEVER, THE SAME MAY BE CHANGED AS PER SITE CONDITIONS / AS DIRECTED BY EIC.

THIS IS THE GENERAL LAYOUT.
FOR LMC AND NON-LMC

OWNER:



PMC:



M/s. VCS QUALITY SERVICES PVT. LTD.

PROJECT:

TITLE: TYPICAL DOMESTIC CONNECTION LAYOUT OF NG DISTRIBUTION

SCALE	DATE	CAD FILE:	CAD	A3
N.T.S.		DATE		

DRG. NO. -20-05-11 REV-0

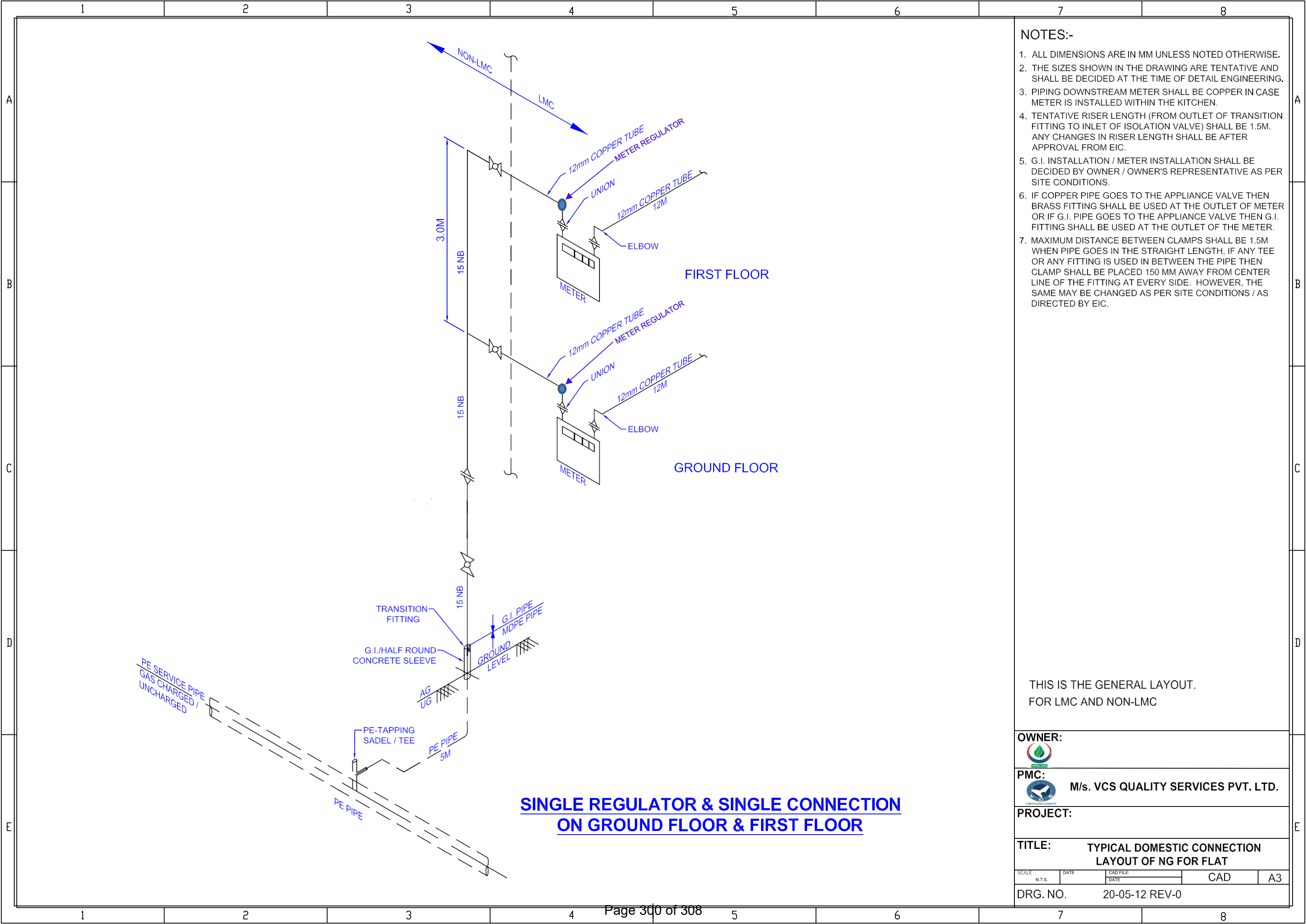

NOTES:-

1. ALL DIMENSIONS ARE IN MM UNLESS NOTED OTHERWISE.
2. THE SIZES SHOWN IN THE DRAWING ARE TENTATIVE AND SHALL BE DECIDED AT THE TIME OF DETAIL ENGINEERING.
3. PIPING DOWNSTREAM METER SHALL BE COPPER IN CASE METER IS INSTALLED WITHIN THE KITCHEN.
4. TENTATIVE RISER LENGTH (FROM OUTLET OF TRANSITION FITTING TO INLET OF ISOLATION VALVE) SHALL BE 1.5M. ANY CHANGES IN RISER LENGTH SHALL BE AFTER APPROVAL FROM EIC.
5. G.I. INSTALLATION / METER INSTALLATION SHALL BE DECIDED BY OWNER / OWNER'S REPRESENTATIVE AS PER SITE CONDITIONS.
6. IF COPPER PIPE GOES TO THE APPLIANCE VALVE THEN BRASS FITTING SHALL BE USED AT THE OUTLET OF METER OR IF G.I. PIPE GOES TO THE APPLIANCE VALVE THEN G.I. FITTING SHALL BE USED AT THE OUTLET OF THE METER.
7. MAXIMUM DISTANCE BETWEEN CLAMPS SHALL BE 1.5M WHEN PIPE GOES IN THE STRAIGHT LENGTH, IF ANY TEE OR ANY FITTING IS USED IN BETWEEN THE PIPE THEN CLAMP SHALL BE PLACED 150 MM AWAY FROM CENTER LINE OF THE FITTING AT EVERY SIDE. HOWEVER, THE SAME MAY BE CHANGED AS PER SITE CONDITIONS / AS DIRECTED BY EIC.

THIS IS THE GENERAL LAYOUT.
FOR LMC AND NON-LMC

OWNER:			
PMC:			
M/s. VCS QUALITY SERVICES PVT. LTD.			
PROJECT:			
TITLE: TYPICAL DOMESTIC CONNECTION LAYOUT OF NG FOR FLAT			
SCALE	DATE	CAD FILE:	
N.T.S.		DATE	CAD A3
DRG. NO.		20-05-12 REV-0	

SINGLE REGULATOR & SINGLE CONNECTION ON GROUND FLOOR & FIRST FLOOR

- NOTES:-**
1. ALL DIMENSIONS ARE IN MM UNLESS NOTED OTHERWISE.
 2. THE SIZES SHOWN IN THE DRAWING ARE TENTATIVE AND SHALL BE DECIDED AT THE TIME OF DETAIL ENGINEERING.
 3. PIPING DOWNSTREAM METER SHALL BE COPPER IN CASE METER IS INSTALLED WITHIN THE KITCHEN.
 4. TENTATIVE RISER LENGTH (FROM OUTLET OF TRANSITION FITTING TO INLET OF ISOLATION VALVE) SHALL BE 1.5M. ANY CHANGES IN RISER LENGTH SHALL BE AFTER APPROVAL FROM EIC.
 5. G.I. INSTALLATION / METER INSTALLATION SHALL BE DECIDED BY OWNER / OWNER'S REPRESENTATIVE AS PER SITE CONDITIONS.
 6. IF COPPER PIPE GOES TO THE APPLIANCE VALVE THEN BRASS FITTING SHALL BE USED AT THE OUTLET OF METER OR IF G.I. PIPE GOES TO THE APPLIANCE VALVE THEN G.I. FITTING SHALL BE USED AT THE OUTLET OF THE METER.
 7. MAXIMUM DISTANCE BETWEEN CLAMPS SHALL BE 1.5M WHEN PIPE GOES IN THE STRAIGHT LENGTH, IF ANY TEE OR ANY FITTING IS USED IN BETWEEN THE PIPE THEN CLAMP SHALL BE PLACED 150 MM AWAY FROM CENTER LINE OF THE FITTING AT EVERY SIDE. HOWEVER, THE SAME MAY BE CHANGED AS PER SITE CONDITIONS / AS DIRECTED BY EIC.

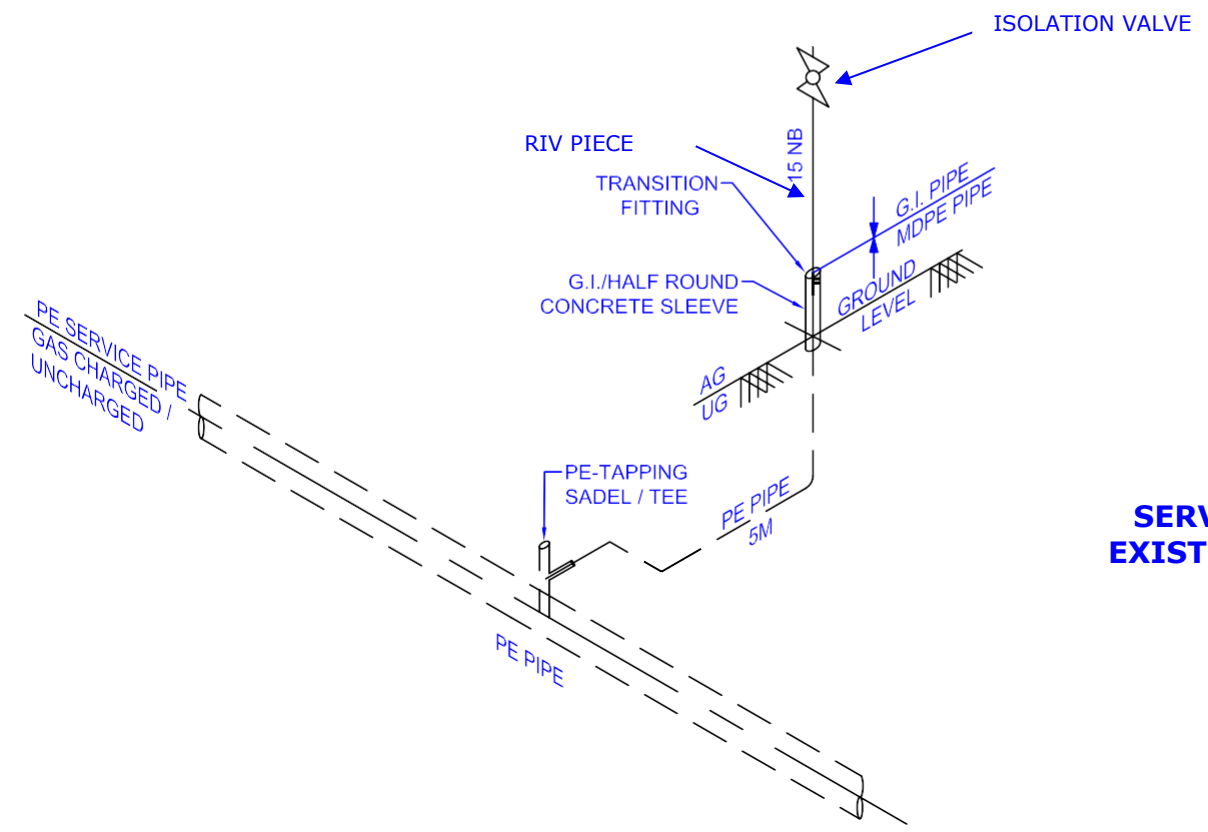

SERVICE PIPELINE CONNECTIVITY FROM EXISTING CHARGED/UNCHARGED PIPELINE

THIS IS THE GENERAL LAYOUT.
FOR LMC AND NON-LMC

OWNER:			
PMC:			
M/s. VCS QUALITY SERVICES PVT. LTD.			
PROJECT:			
TITLE: TYPICAL SERVICE PIPELINE LAYOUT			
SCALE	DATE	CAD FILE:	
N.T.S.		DATE	CAD A3
DRG. NO.		-20-05-14 REV-0	

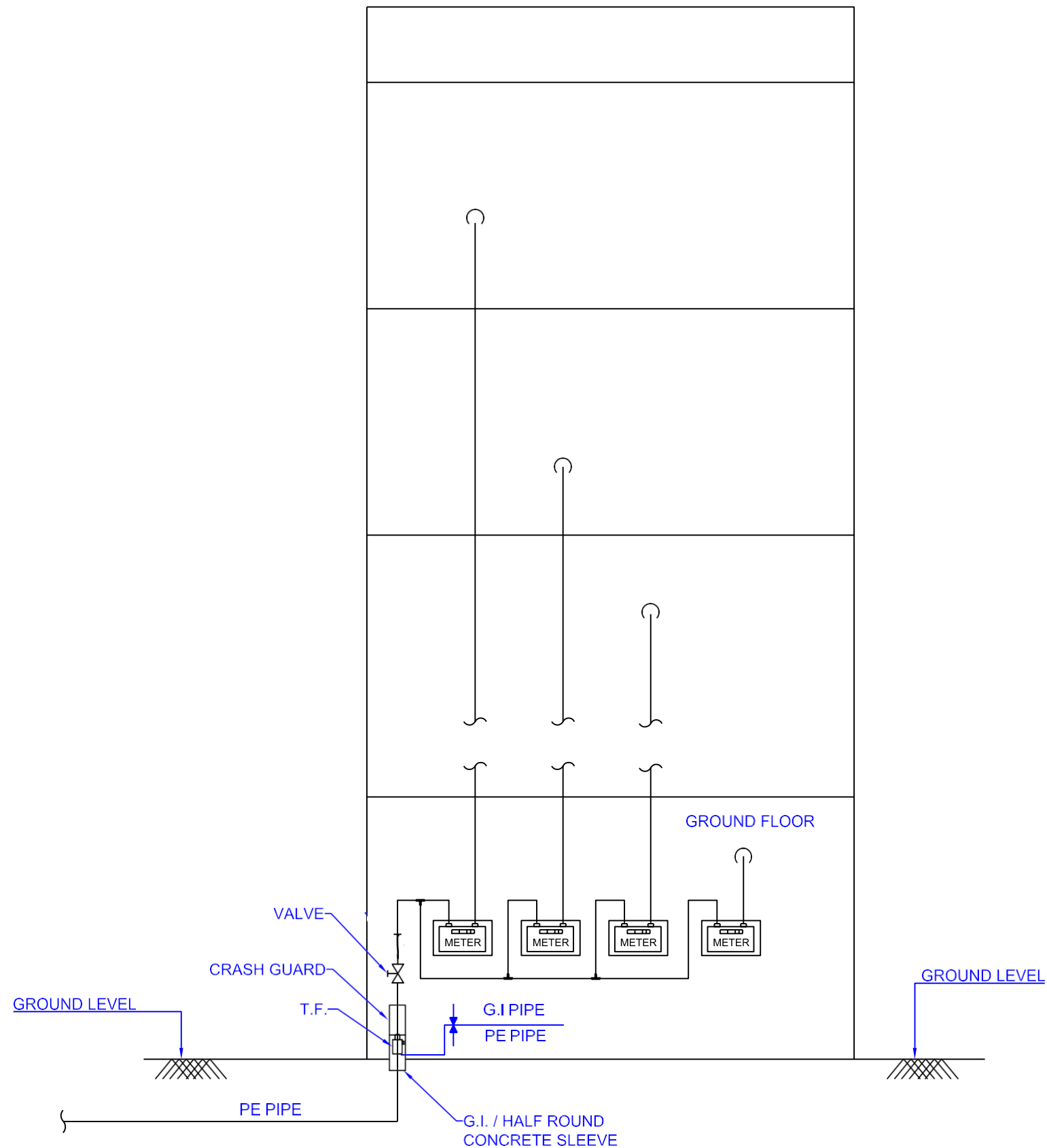

INDICATIVE RISER ARRANGEMENT IN BUILDING,
IF METER INSTALLED AT GROUND FLOOR

NOTES:-

1. ALL DIMENSIONS ARE IN MM UNLESS NOTED OTHERWISE.
2. THE SIZES SHOWN IN THE DRAWING ARE TENTATIVE AND SHALL BE DECIDED AT THE TIME OF DETAIL ENGINEERING.
3. PIPING DOWNSTREAM METER SHALL BE COPPER IN CASE METER IS INSTALLED WITHIN THE KITCHEN.
4. TENTATIVE RISER LENGTH (FROM OUTLET OF TRANSITION FITTING TO INLET OF ISOLATION VALVE) SHALL BE 1.5M. ANY CHANGES IN RISER LENGTH SHALL BE AFTER APPROVAL FROM EIC.
5. G.I. INSTALLATION / METER INSTALLATION SHALL BE DECIDED BY OWNER / OWNER'S REPRESENTATIVE AS PER SITE CONDITIONS.
6. IF COPPER PIPE GOES TO THE APPLIANCE VALVE THEN BRASS FITTING SHALL BE USED AT THE OUTLET OF METER OR IF G.I. PIPE GOES TO THE APPLIANCE VALVE THEN G.I. FITTING SHALL BE USED AT THE OUTLET OF THE METER.
7. MAXIMUM DISTANCE BETWEEN CLAMPS SHALL BE 1.5M WHEN PIPE GOES IN THE STRAIGHT LENGTH, IF ANY TEE OR ANY FITTING IS USED IN BETWEEN THE PIPE THEN CLAMP SHALL BE PLACED 150 MM AWAY FROM CENTER LINE OF THE FITTING AT EVERY SIDE. HOWEVER, THE SAME MAY BE CHANGED AS PER SITE CONDITIONS / AS DIRECTED BY EIC.
8. TAPPING SHALL BE LEFT NEAR OUTSIDE THE KITCHEN AS DIRECTED BY OWNER / OWNER'S REPRESENTATIVE.
9. FROM TRANSITION FITTING TO THE ISOLATION VALVE, SHALL BE CONSIDERED IN THE OUTSIDE KITCHEN PIPING.
10. AT THE TIME OF MEASURING LENGTH OF G.I./COPPER PIPE, G.I./COPPER FITTINGS SHALL BE COUNTED IN THE PIPE LENGTH.

THIS IS THE GENERAL LAYOUT.
FOR LMC AND NON-LMC

OWNER:



PMC:



M/s. VCS QUALITY SERVICES PVT. LTD.

PROJECT:

**TITLE: TYPICAL DOMESTIC CONNECTION
LAYOUT OF NG DISTRIBUTION**

SCALE N.T.S.	DATE	CAD FILE: DATE	CAD	A3
-----------------	------	-------------------	-----	----

DRG. NO. -20-05-15 REV-0

NOTES:-
 1. ALL DIMENSIONS ARE IN MM UNLESS NOTED OTHERWISE.
 2. FOLLOW WRITTEN DIMENSIONS ONLY. DO NOT SCALE THE DRAWING.

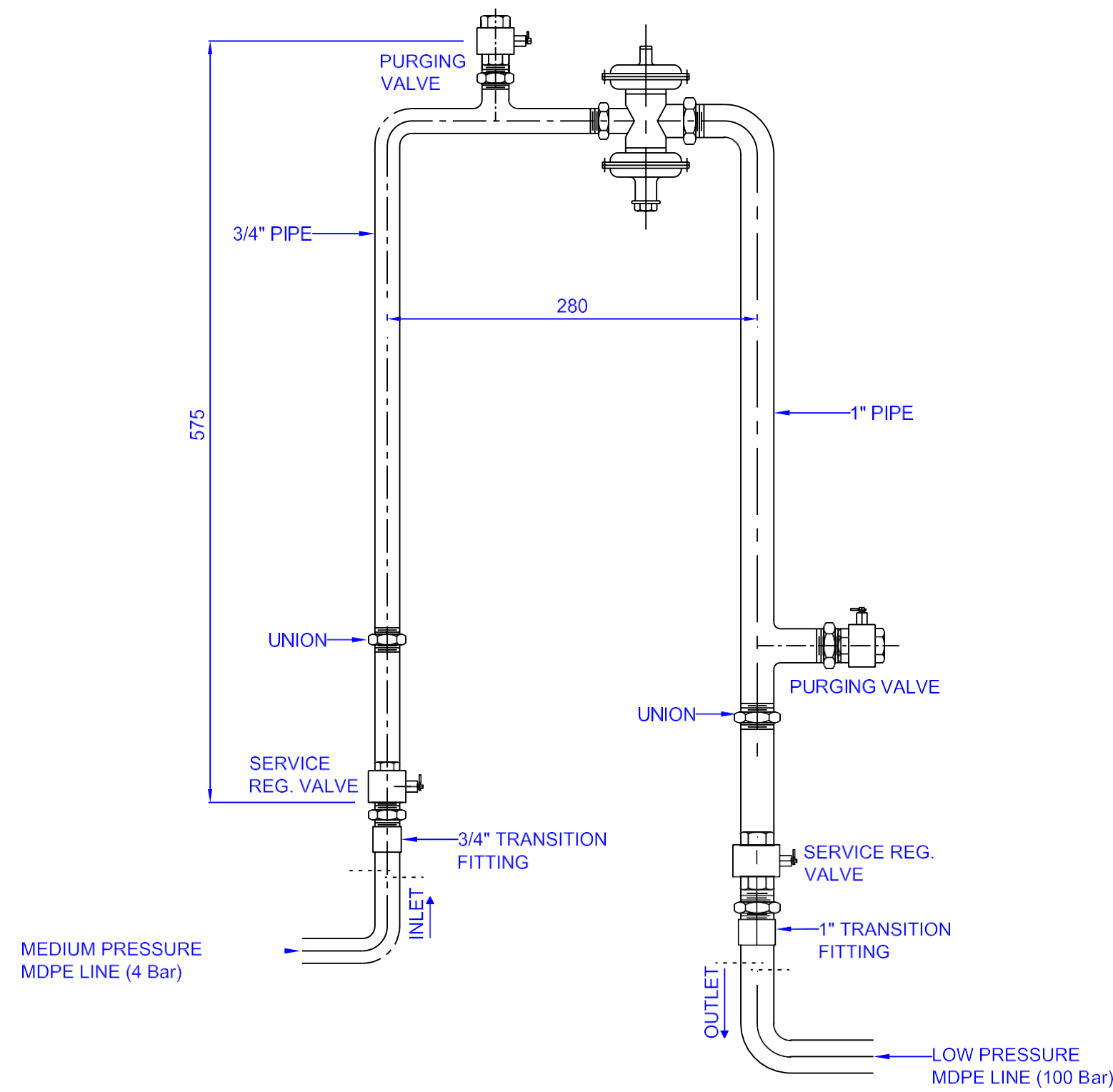

OWNER:				
PMC: M/s. VCS QUALITY SERVICES PVT. LTD.				
PROJECT:				
TITLE: SCHEMATIC DIAGRAM FOR SINGLE STREAM REGULATOR				
SCALE 1:4	DATE	CAD FILE DATE	CAD	A3
DRG. NO. -20-05-37 REV-0				

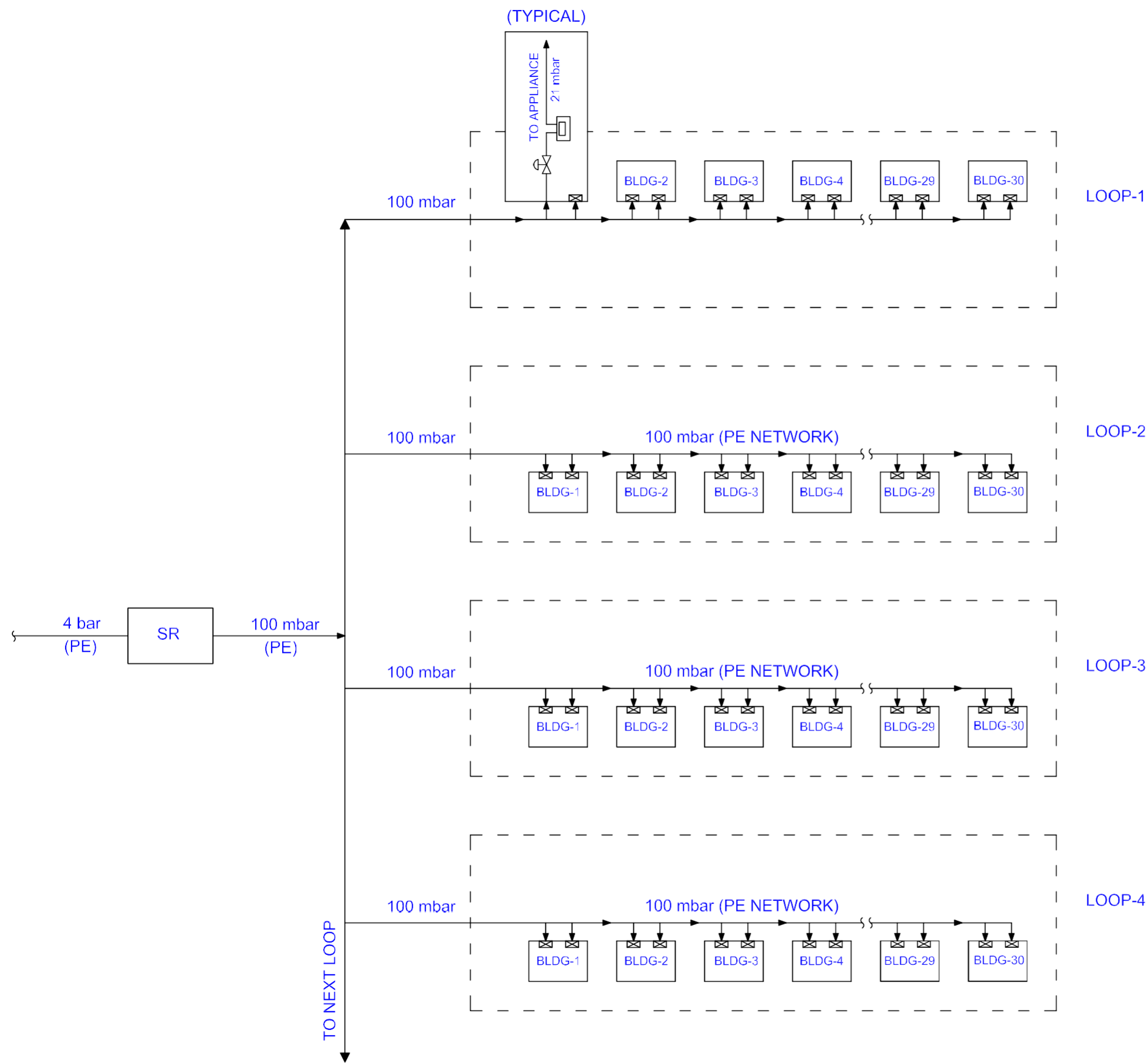

NOTES:-

1. ALL DIMENSIONS ARE IN MM UNLESS NOTED OTHERWISE.
2. FOLLOW WRITTEN DIMENSIONS ONLY. DO NOT SCALE THE DRAWING.

OWNER:



PMC:



M/s. VCS QUALITY SERVICES PVT. LTD.

PROJECT:

TITLE: SCHEMATIC DIAGRAM DESCRIBING DIFFERENT PRESSURE SYSTEM (SR TO APPLIANCE IN KITCHEN)

SCALE	DATE	CAD FILE	CAD	A3
N.T.S				

DRG. NO. -20-05-40 REV-0

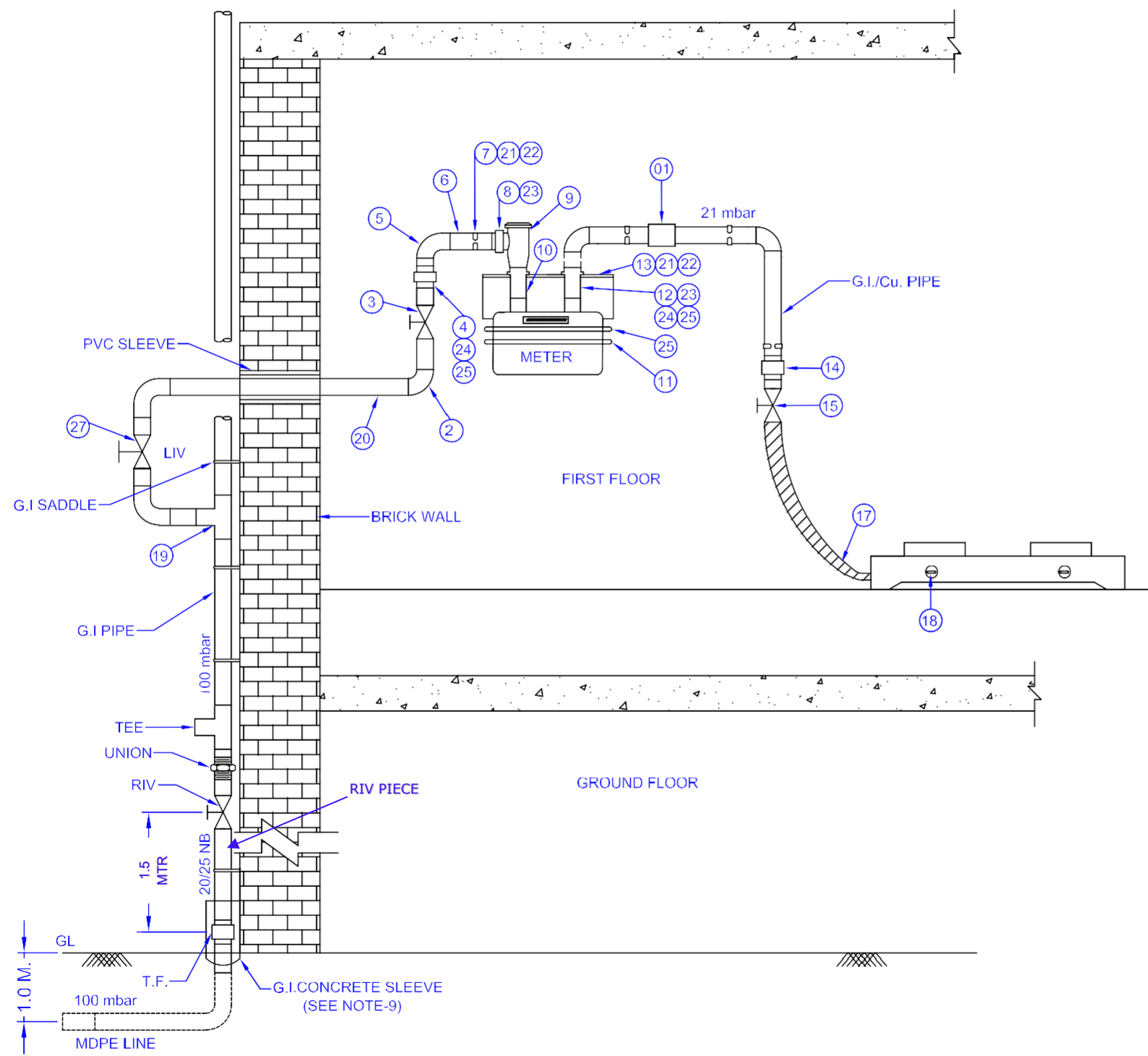

NOTES:-

1. ALL DIMENSIONS ARE IN MM UNLESS NOTED OTHERWISE.
2. THE SIZES SHOWN IN THE DRAWING ARE TENTATIVE AND SHALL BE DECIDED AT THE TIME OF DETAIL ENGINEERING.
3. PIPING DOWNSTREAM METER SHALL BE COPPER IN CASE METER IS INSTALLED WITHIN THE KITCHEN.
4. TENTATIVE RISER LENGTH (FROM OUTLET OF TRANSITION FITTING TO INLET OF ISOLATION VALVE) SHALL BE 1.5M. ANY CHANGES IN RISER LENGTH SHALL BE AFTER APPROVAL FROM EIC.
5. G.I. INSTALLATION / METER INSTALLATION SHALL BE DECIDED BY OWNER / OWNER'S REPRESENTATIVE AS PER SITE CONDITIONS.
6. IF COPPER PIPE GOES TO THE APPLIANCE VALVE THEN BRASS FITTING SHALL BE USED AT THE OUTLET OF METER OR IF G.I. PIPE GOES TO THE APPLIANCE VALVE THEN G.I. FITTING SHALL BE USED AT THE OUTLET OF THE METER.
7. MAXIMUM DISTANCE BETWEEN CLAMPS SHALL BE 1.5M WHEN PIPE GOES IN THE STRAIGHT LENGTH, IF ANY TEE OR ANY FITTING IS USED IN BETWEEN THE PIPE THEN CLAMP SHALL BE PLACED 150 MM AWAY FROM CENTER LINE OF THE FITTING AT EVERY SIDE. HOWEVER, THE SAME MAY BE CHANGED AS PER SITE CONDITIONS / AS DIRECTED BY EIC.
8. TAPPING SHALL BE LEFT NEAR OUTSIDE THE KITCHEN AS DIRECTED BY OWNER / OWNER'S REPRESENTATIVE.
9. G.I. CONCRETE SLEEVE INSTALLATION SHALL BE DECIDED BY OWNER / OWNER'S REPRESENTATIVE AS PER SITE CONDITIONS.
10. REGULATOR TO BE FIXED NEAR THE METER AS PER INSTRUMENT AS PER INSTRUCTION OF EIC.

BILL OF MATERIAL

SR No.	MATERIAL DESCRIPTION	QTY.	REMARK
1.	COPPER COUPLER	01	
2.	90 DEG. ELBOW G.I.(1/2"x12mm)	01	
3.	METER CONTROL VALVE (1/2")	01	
4.	BRASS DISCONNECTING UNION (1/2"x12mm)	01	
5.	G.I./Cu ELBOW (12mm)	02	
6.	G.I./Cu TUBE(12mm)	3m	INDICATIVE
7.	PVC. CLIP	05	
8.	BRASS DISCONNECTING UNION (3/4"x12mm)	01	
9.	METER REGULATOR	01	
10.	METER INLET UNION (3/4"x3/4")	01	
11.	GAS METER (2.5 m3/hr)	01	
12.	METER OUTLET UNION (3/4"x12mm)	01	
13.	METER BRACKET	01	
14.	BRASS ADAPTER(1/4"x12mm)	01	
15.	APPLIANCE VALVE WITH NOZZLE (1/4")	01	
16.	GAS STOVE	01	
17.	STEEL REINFORCED RUBBER HOSE	1m	TYPICAL
18.	NOZZLE JET	02	
19.	COPPER EQUAL TEE	01	OPTIONAL
20.	25mm OD, PVC, PIPE AS PER IS - 4986	01	
21.	RAWAL PLUGS	07	
22.	WOOD SCREW	07	
23.	TEFLON TAPE	4m	INDICATIVE
24.	SOLDER WIRE	20 gms	
25.	FLUX	15 gms	
26.	METER CLAMP	01	
27.	LATERAL VALVE	01	

THIS IS THE GENERAL LAYOUT.

OWNER:



PMC:

M/s. VCS QUALITY SERVICES PVT. LTD.

PROJECT:

TITLE: TYPICAL DOMESTIC CONNECTION LAYOUT OF NG DISTRIBUTION

SCALE: N.T.S.	DATE:	CAD FILE: DATE:	CAD	A3
---------------	-------	-----------------	-----	----

DRG. NO. -20-05-07 REV-0

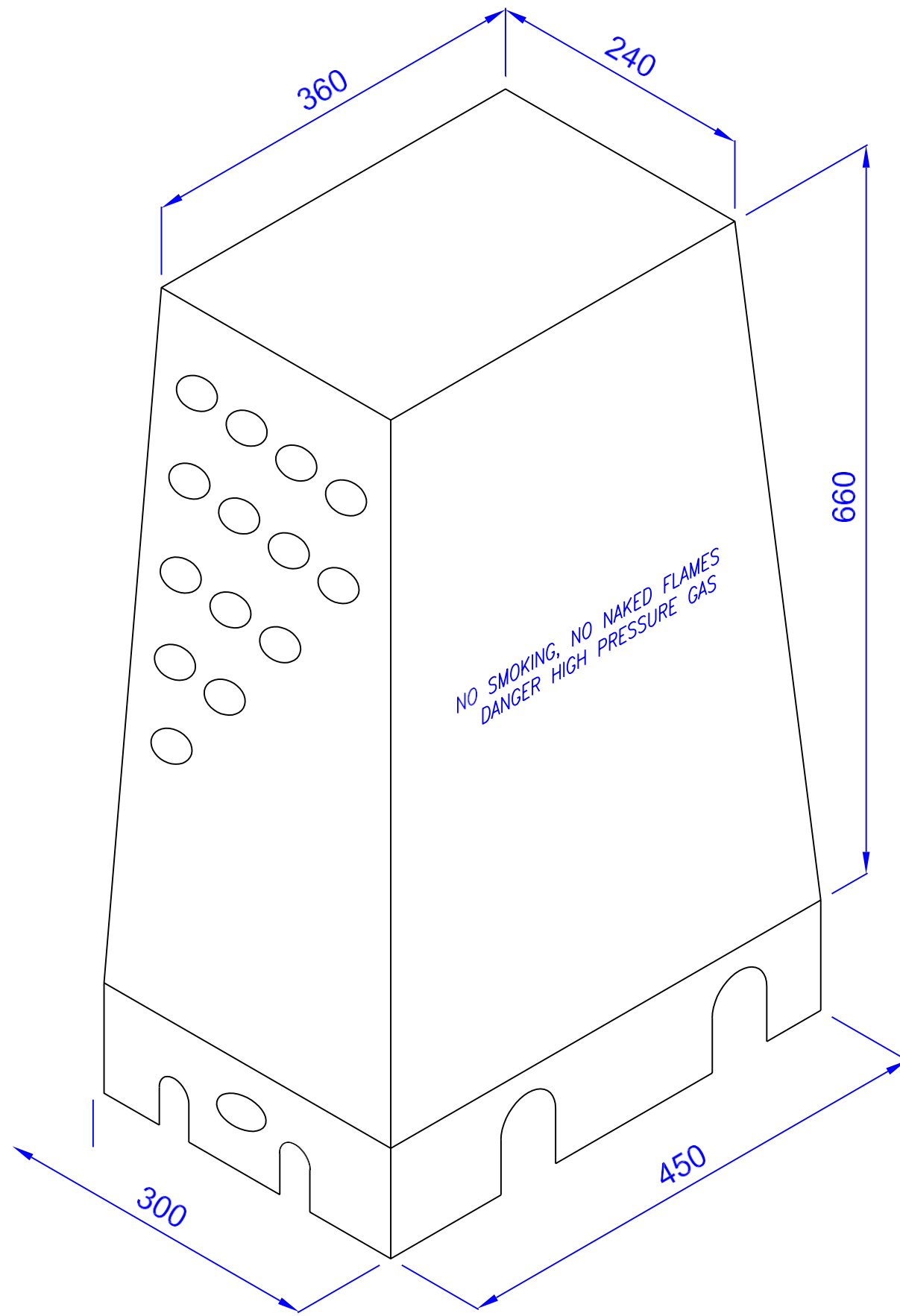

NOTES:-

1. ALL DIMENSIONS ARE IN MM UNLESS NOTED OTHERWISE.
2. THE HOUSING SHOULD BE OF FIBER REINFORCED PLASTIC (FRP).
3. 40mm GROUTING WITH NON SHRINKAGE COMPOUND SHALL BE PROVIDED AT BOTTOM OF SERVICE REGULATOR.

OWNER:



PMC:



M/s. VCS QUALITY SERVICES PVT. LTD.

PROJECT:

TITLE: SCHEMATIC DIAGRAM OF HOUSING FOR SINGLE SERVICE REGULATOR

SCALE 1:5	DATE	CAD FILE: DATE	CAD	A3
--------------	------	-------------------	-----	----

DRG. NO. -20-05-42 REV-0

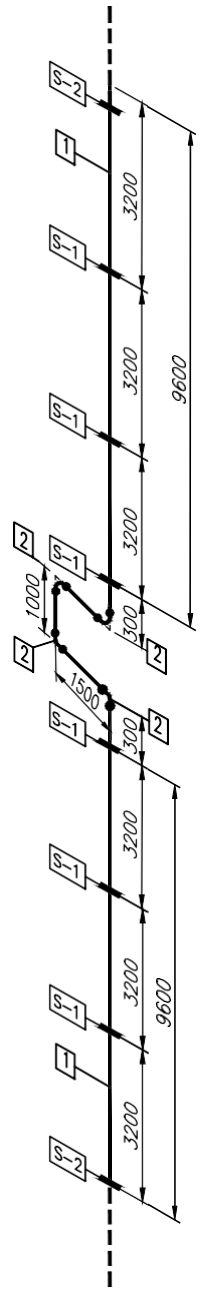

OPTION-A
(LOOP SIZE-1500X1000)

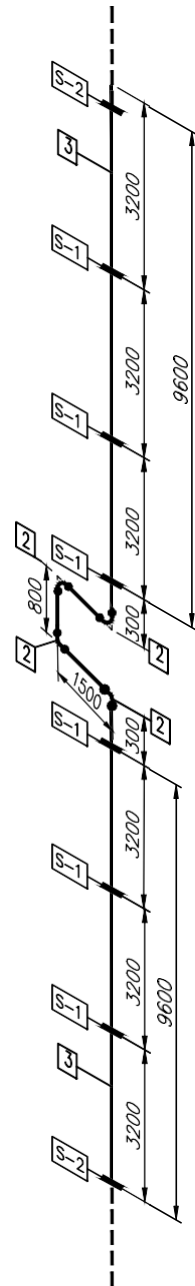

OPTION-B
(LOOP SIZE-1500X800)

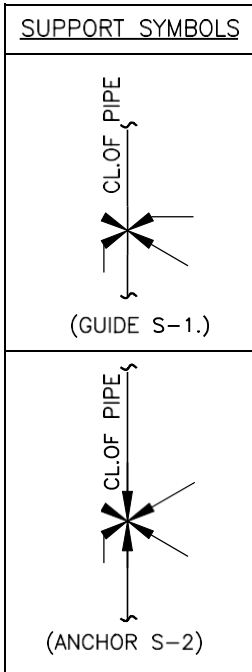

BILL OF MATERIAL				
S.NO.	SIZE (NB)	DESCRIPTION	QTY.	UNIT CODE
1	50	GI PIPE -IS-1239 PART-1	20.8	M
2	50	ELBOW 90°	04	Nos.
3	50	GI PIPE -IS-1239 PART-1	20.6	M

NOTES:-

1. ALL DIMENSIONS ARE IN MM UNLESS NOTED OTHERWISE.

OWNER:

PMC: M/s. VCS QUALITY SERVICES PVT. LTD.

PROJECT:

TITLE: EXPANSION LOOP FOR RISER
IN HIGH RISE BUILDING

NAME: _____ DATE: _____

CAD A3

