



**HPOIL GAS PRIVATE LIMITED**  
**(A Joint Venture of HPCL & OIL)**

**TENDER FOR PROVIDING OPERATION AND MAINTENANCE SERVICES  
FOR MDPE AND STEEL NETWORK AT KOLHAPUR GA**

**TECHNICAL VOLUME**

**PART B**

**TENDER NO. HOGPL/2026-27/C&P/011**

**DATE: 03.06.2026**

## 1 INTRODUCTION

HPOIL Gas Pvt Ltd is engaged in supplying Piped Natural Gas (PNG) to Households, Commercial & Industrial consumers, and Compressed Natural Gas (CNG) to Automotive sector through gas pipeline network. HPOIL GAS is authorized to expand CGD network in Ambala-Kurukshetra, Kolhapur & Nagaland GA.

HPOIL GAS is now inviting tenders on competitive bidding process for providing services for preventive maintenance, breakdown/emergency repairs and monitoring of PNG network consisting of underground Steel pipelines, PE main pipelines, Service pipelines and GI/Cu installations and associated facilities in Kolhapur GA to provide uninterrupted supply of gas with due compliance to all prevailing statutory & HSE norms keeping in view the customers satisfaction.

### **Existing & upcoming PE network & PNG connection details for Kolhapur GA:**

Sr. No.	Asset Description	UOM	Existing Asset	Cumulative Assets up to 2 years
1	PE Network Laid	Km	698.68	900
2	PE Network Commissioned	Km	456.72	900
3	Steel Network	Km	101.4	110
4	PNG Connections Installed	Nos.	39515	45500
5	PNG Connections FC	Nos.	13101	45500

## 2 SCOPE

Scope of work for Bidder under this document is for O&M activities of Steel Network & downstream of DRS to Domestic/Commercial/Industrial connection including MDPE network, GI piping, isolation Valves, Valve Chambers, Service Regulators, etc. This includes all O&M activities i.e Preventive/breakdown maintenance, Leak Repair of MDPE & Steel Network, Addition /Modification /Shifting /Decommissioning /upkeeping /commissioning of existing assets based on requirement for all Geographical Areas. The scope includes steel and MDPE pipeline patrolling and capturing CP readings. However, the first response to any emergency on steel distribution network and DRS/DCU/MRS /SR/ Valves/ CGS metering Skids & allied equipment will be the responsibility of the bidder under AEO (Area Emergency Office) Team.

The main scope of the bidder includes but not limited to providing of services including manpower, safety equipment, tools-tackles, PPEs, First Aid Kits, consumables, materials, vehicle etc. for all O&M activities & maintaining emergency office complaint management through emergency numbers relation, for grievances/ queries received through calls, letters, emails, through toll free number and other modes/ receiving calls directed from Central customer care center / emergency handling of complaints & Meter reading related works and intimation to AEO Team for O&M activities as per customer complain / resolution of queries as required for industrial, commercial & domestic customers.

Owner shall supply all size of GI pipes, PE pipes, Isolation valves, Appliance valves, PE ball valves (for replacement only), domestic gas meters, domestic meter regulators, service regulators. Whereas rest of the materials such as GI/PE fittings, warning tape, all type of consumables items, clamps or any other fittings not mentioned here but required to perform task shall be supplied by Bidder. All materials which are to be supplied by bidder shall be as per technical specifications of HPOIL GAS and shall be used at site after inspection/approval by HPOIL GAS team. The total scope of this document is divided into two parts for clarity on SOR items.

## 2.1 BRIEF SCOPE COVERED IN PART- I i.e. SOR Line Items No. 1 to 13.

- Supply of all required resources such as Manpower, Equipment, tools & tackles, PPEs, Materials, Consumables, Administrative operation round the clock to carry out activities as per detailed scope of work mentioned in Part - I.
- Providing and maintaining AEO / Mini AEO Office and store space with necessary office/store furniture/equipment/amenities as per requirement mentioned in Scope Part- I.
- Deployment of Emergency Vehicle including Fuel, Driver, Consumables, Maintenance etc.
- Deployment of Two-Wheeler along with VTS as per Owner's requirement.
- Capturing Meter Readings & Bill circulation for Domestic, Industrial & Commercial connections.
- Attending customer/emergency complaints, removing GI pipe from customer's premise.

## 2.2 BRIEF SCOPE COVERED IN PART- II i.e. SOR Line Items 14 to 120.

Supply of materials & labor charges for Diversions, Alterations, Modifications, PE Pipeline laying/shifting, LMC Installation, Meter Installations for new I&C connections, Steel Pipeline leak repairs, Installation of Route markers/PE Valves, Construction of Valve Chambers, Preventive Maintenance of Domestic/Commercial/Industrial connections, Civil & other structural works, painting etc. based on request/requirement of Owner. All jobs will be performed as per requirement of T4S & other PNGRB standards and applicable maintenance codes, bidder shall conform to the safety requirements of HPOIL GAS as per site requirements.

\*The rates mentioned in Part II are inclusive of manpower & fittings charges, AEO team shall not be engaged in execution of these activities.

- Cleaning of SV & PE valve chambers.
- Domestic Connection Preventive Maintenance at 1-Year frequency.
- Hiring of JCB, Hydra, Dewatering pump, Air compressor etc.
- Refitting of GI pipe.
- Domestic Connection Leak Detection at 1-Year frequency.
- Domestic Connections Alterations.
- Installation of new PE Ball Valve along with construction of valve chamber.
- Shifting/laying of PE pipeline for O&M purpose.
- Laying of PE Service pipeline for connecting Domestic/Industrial/Commercial customers.
- Installation of Service regulators Modules including box along with foundation.
- Installation of route marker.
- MRS/Meter Shifting of Commercial/Industrial Connection within premises.
- SV Chamber Cleaning/Maintenance.
- Attend and repair Emergency Leakages in Steel Pipeline of 4",6",8",12".

Note - Please refer detailed scope covered under Part-I, Part-II and SOR for more understanding.

## 3 DEFINITIONS & ABBREVIATIONS

AEO	Area Emergency Office, for carrying out round the clock (24 hours and 365 days) Operation & Maintenance activities.
CRM	Customer Relation Management for maintaining customer care relation, Billing & Meter reading related works.
AOMP	Annual Operation and Maintenance Plan
Bidder	The Party / Person, who are bidding for obtaining the O & M Job / Contract.
Consumer Meter	A meter that measures gas delivered to a consumer at the consumer's premises
Commercial Customer Connection	Consist of Meter/MRS, regulators, PE/GI piping, Isolation valves, etc. to supply gas for commercial purpose
Domestic Customer Connection	Consist of regulator, meter, P E / GI / copper pipeline and armored rubber tube. Gas flow at 21-24 mbar and consumed at hot plate

Electro Fusion Joint	A joint made in thermo plastic piping by passing the current through the electrical coil provided in the fitting and heating the parts sufficiently to permit adequate flow and fusion of the materials between the two surfaces put in contact
Fire Extinguishers	For extinguishing fire accident during routine job
Emergency Vehicle	A vehicle for attending regular and emergency activities of PNG Network
Industrial Customer Connection	Consist of Meter/MRS, regulators, PE/GI piping, Isolation valves, etc. to supply gas for industrial purpose
Owner	The Principal Requesting the Works to which the Agreement relates i.e. "HPOIL GAS and its subsidiary companies"
Portable Gas Detector	For detecting / measuring gas presence during leaks / escape / maintenance jobs.
Personal Protection	For personal protection during normal and critical jobs.
Piped Natural Gas (PNG)	Natural Gas produced from Gas wells, Gas condensate wells or Oil wells and the residue Gas remaining after conditioning being metered, regulated / controlled, odorized & distributed through pipelines for various applications, i.e. for industrial, commercial, domestic, etc. as a Fuel.

Public Announcement System	For making public announcement to customer during gas supply stoppage, resumption, disaster, earthquake, fire hazards etc.
Secondary Network	Secondary Network means a part of CGD network that operates at a pressure below 100 psig (7 bar) and above 1.5 psig (110 mbar) and pipelines forming part of this network shall be called Medium-Pressure Distribution Mains which shall be designed to ensure uninterrupted supply to tertiary network or to industrial consumers.
Standard Dimension Ratio	Standard Dimension Ratio is the ratio of nominal OD to nominal wall thickness of PE pipe as defined in IS-14885, with latest edition.
Tertiary Network	Tertiary Network means a part of the CGD Network that operates at a pressure less than 1.5 psig (100 mbar) and pipelines forming a part of this network to service pressure distribution mains shall be designed to ensure uninterrupted gas supply to Service lines
Transition Box / Service Regulator	Receives 0.5 to 4 bar pressure gas through PE network and supply 110 mbar pressure gas to downstream PE network after pressure reduction
Tools & Tackles	For repair / maintenance of leaking / damaged PE / GI pipes, fittings on PE/GI network, online functional testing of PE valves and service regulators and customer connection
EIC	: Engineer-In-Charge
HIRA	: Hazard Identification and Risk Assessment
HSE	: Health, Safety & Environment
LDT	: Leak Detection Test
LPT	: Lock Pressure Test
PE	: Polyethylene
MP	: Medium Pressure
LP	: Low Pressure
PPE	: Personal Protective Equipment
PRV	: Pressure Reducing Valve
SOP	: Standard Operating Procedure
SRV	: Safety Relief Valve
SSV	: Safety Shut-off Valve
QAP	: Quality Assurance Plan

#### 4 HSE, COMPETENCY & TRAINING AND GENERAL REQUIREMENTS:

Apart from specific job-related responsibilities and requirements, there are certain general rule and

regulations that must be followed by all working persons of Bidder as follows:

- 4.1 The bidder shall conform to the safety requirements of HPOIL GAS as per site requirement. In addition, the bidder shall observe safe working practices in the storage and handling of cleaning fluids, flammable fluids etc. and ensure smoking or naked flames are not permitted in the vicinity when these materials are being used.
- 4.2 The bidder shall also protect all work sites with warning signs, caution tapes, barricades and night lighting as per HPOIL GAS specification. The bidder shall inspect all fenced excavations daily and maintain them in good order.
- 4.3 The trenches / pits shall not be kept open in night times. However, in case the same is essential then same shall be properly barricaded with proper lighting arrangements & manned.
- 4.4 The bidder shall provide PPEs like reflective jackets, safety helmets, safety shoes, goggles, hand gloves etc. to the labor and staff which are necessary for safe working practices. Any additional job specific PPE shall be also provided by the bidder.
- 4.5 Use of portable gas detectors, oxygen meters, hot / cold work permits is mandatory for confined space entry and before start of any hot work. Above activities shall be avoided if oxygen level is below 19.5 % and leakage of NG is more than 0 % of LEL.
- 4.6 BIDDER shall provide relevant trainings (Technical / Fire & Safety, etc) to his personnel from time to time for better functioning of the O&M at his cost and risk, without affecting Operations. OWNER may provide special training, to be required; hence, BIDDER shall deploy his personnel for such trainings.
- 4.7 Bidder shall train his manpower for reporting HAZARD and NEAR MISS if any happened in their working area. The bidder shall employ person who must have certain qualifying requirements in terms of qualification, knowledge, skill, behavior to achieve the job end results. After recruiting the new person for proposed job / duty, he should be trained, educated, tested, certified and declared competent to perform the job effectively, in scheduled time with safety, quality and statutory compliances.
- 4.8 Competency training and test should be regularly conducted to ensure that the certified person still possess the required competency to perform the job with specific requirements.
- 4.9 Any change in operating procedure, process, change in equipment and layout also need retraining, competency retest and certification. The training may be in-house, or out-house and it starts with the induction, for new recruits, and refresher or need based training for existing employees, to check, maintain their competency level. The training may be in classroom for understanding theory or in plant or simulation for practical purpose.
- 4.10 BIDDER must comply and carry out entire scope of work as per OWNER requirement.
- 4.11 BIDDER shall have knowledge of minimum service level standard issued by PNGRB and shall comply the requirements of Owner
- 4.12 BIDDER must ensure that his personnel are well behaved, consumer oriented, non-alcoholic or prohibited drugs addict. Any misbehave with consumer as well as OWNER's representative shall be liable to be punishable and even to the extent of removal of those personnel from duties. BIDDER shall not engage or employ any person with a criminal record / background.
- 4.13 BIDDER's personnel shall be educated, trained and experienced in Gas Distribution operation & maintenance with due aware of the prevailing codes / standards applicable to the activities from time to time. BIDDER's personnel should possess good communication for consumer call attendance, site communication (Tele or Wireless), etc.
- 4.14 BIDDER shall, at its own cost, provide uniforms , raincoat , caps and identity card to its employees deployed at the station and shall ensure that such uniforms / identity card are worn by his employees while on duty for all the personnel & especially for consumer services / site works. To enable OWNER to maintain the identity, the BIDDER shall follow the identity card & dress code prescribed by OWNER.
- 4.15 BIDDER shall be responsible for maintaining harmonious relation with his employees, OWNERS representative, Customers etc and shall inform OWNER of any stoppage of work or other labour dispute whether actual or threatened and which is likely to affect the supply / operations. In the event of any strike or stoppage of activities, OWNER shall have an unconditional right to depute and deploy its personnel / representatives and BIDDER shall not have any right of objection for entry of OWNER / OWNER's representative. In such case, OWNER shall recover the cost from BIDDER at actual to be payable therein.
- 4.16 BIDDER's personnel, who will be working on site, should have or should gain thorough knowledge of gas line & geography of the area so that any spot / customer house can be quickly located.
- 4.17 BIDDER should also be acquainted with the hazardous properties of gas and the potential effect of escaping gas on the safety of the public. It should be emphasized and encouraged that in the event of an emergency that prompt co-operative action would be required.

- 4.18 Apart from the essential day to day contact with other Authorities, BIDDER / OWNER shall formally correspond with the appropriate other Authorities on a yearly or periodically.
- 4.19 Bidder shall follow the requirements of Safe Control Operation requirements of HPOIL GAS which consists of PTW, NRO and MOC and should carry out Risk Assessment, Job Safety Analysis for each job.
- 4.20 Bidder should employ a safety personnel (Diploma/Certification in fire and safety and relevant experience of 1 year) and other personnel's complying to requirements PNGRB IMS requirements to oversee safe operation/jobs – Appendix III of IMS (Emergency Response, Valve Maintenance, Pipe replacement, Fire and Safety)
- 4.21 Minimum document requirement (viz Address proof, medical reports) as specified by HPOIL GAS shall be mandatorily submitted as and when required.

## Part-I

### 5 DETAILED SCOPE COVERED UNDER PART-I (LINE ITEMS 1-13):

The scope of this document is to set down the minimum day to day operational and maintenance requirements for PNG City Gas Distribution Network from downstream of CGS up to LMC network. The following activities have to be covered mandatorily with the manpower supplied by bidder. Non-performance of any of the activities will be liable for penalties specified in the document including termination of the contract if needed. All these activities will be henceforth considered as "Basic Services".

#### 5.1 The Bidder's scope of work will consist of but not limited to:

- 5.1.1 Emergency complaint handling/Leakage repairing/ of Steel/MDPE pipeline, consumer complaints & service requests/ preventive / breakdown maintenance services/repairs of PE gas distribution network from downstream of DRS up to the consumption point (for domestic consumer up to appliance valve including rubber hose and for commercial & industrial consumer up to meter outlet) to ensure uninterrupted Gas supply and any other work not mentioned herein but required for safe and smooth functioning of GI/Cu pipeline system including meter and regulator.
- 5.1.2 The scope includes patrolling of entire steel & MDPE network, capturing CP readings & the first response to any emergency on MDPE, GI & steel distribution network and DRS/DCU/MRS will be the responsibility of the AEO and Mini AEO Team.
- 5.1.3 Mobilization of all resources 24 hours x 365 days to handle any type of emergency and first response at any incident site after communication received from HPOIL GAS / any other source within the stipulated response time given in the SLA table.
- 5.1.4 Emergency complaint handling in PNG distribution network and maintenance services of PE pipeline network consisting of 20 mm to 125 mm size of PE pipes which includes attending pipeline damages / gas escapes / fire / shutdowns etc., monitoring third party digging work through patrolling & utility co-ordination; inspection and leakage repair of PE valves, Leakage repair & housekeeping of SR, inspection of pipeline route markers; testing for leakages using gas detector and taking appropriate action as per instruction of HPOIL GAS representative.
- 5.1.5 Attending to customer complaints within stipulated **SLA – Annexure- 2** as defined by Owner includes Attending "NO GAS" complaints i.e. complaint of gas not coming in the customer's house; Attending "FLAME PROBLEM" complaints i.e. complaint of High or Low flame of Stove in the customer's house; Attending "GAS LEAK" complaints i.e. complaint of any minor Gas leak from the Stove or inside the Kitchen or from outside areas as per the customer notification; meter related complaints, meter replacement, connection verification, rubber hose replacement on customer request, Attending "TEMPORARY/ PERMANENT DISCONNECTION", "RECONNECTION", "TEMPORARY DISCONNECTION - DUNNING" complaints; refitting/fixing RCC guard and attending any other complaint not mentioned herein but made by consumer related to PNG supply. Attending Removal / dismantling / decommissioning of LMC connections/GI pipe on customer request. Yearly preventive maintenance of Commercial & Industrial Connections upto meter outlet.

Note: No separate rate shall be payable for removal of GI pipes for alteration, dismantling/force dismantling of GI pipes for domestic LMC connections and preventive maintenance of I&c connections, the rates are inclusive in supply of AEO team. The job has to be performed by GI Technician which is part of AEO Team.

- 5.1.6 AEO office with provision for Stores for which rent will be paid by Bidder. Location of the AEO office should be such that emergency vehicle can reach to every corner of AEO's allotted area of operation within the stipulated response time defined in the SLA. AEO office shall have minimum area of 750 Sq. Ft and shall consist of minimum space to accommodate change room, Toilets & storeroom for materials, Pantry , Drinking water , power back up , Internet, computer/Laptop minimum two nos, emergency spares, tools & tackles with dedicated parking place for Emergency Vehicle. MINI AEO Office shall have same setup as AEO Office and shall have the Minimum Area of 250 Sq. Ft along with Basic facilities.
- 5.1.7 Supply of Manpower, Emergency Vehicle & Two-Wheeler required for preventive & breakdown maintenance of assets, downstream of DRS/DCU/MRS including Inventory Management at store is in bidder's scope of services.
- 5.1.8 Emergency Vehicle charges shall include fuel, driver, maintenance, vehicle tracking system, vehicle insurance & RTO Charges etc. The vehicle deployed shall have customized body with adequate cabinets/lockers for carrying tools, tackles & spares including branding of the vehicle as per the design and color code given by Owner. Separate charges will be paid for deploying Emergency vehicle as per the rate quoted in the S.O.R.

- 5.1.9 Modification / shifting / dismantling / decommissioning / repair of PE network.

Note: Mdpe pipeline laying/shifting in case of damage/repair upto 3 mtrs shall be done by AEO team without any additional cost to HPOIL Gas the mdpe pipe & PE fittings will be provided by HPOIL/SOR and no sperate per meter rates will be provided for leak repair / laying upto 3 mtrs, beyond 3 mtrs laying can be claimed through SOR items of Mdpe laying of relevant dia. size in which the fittings shall be in bidders scope only mdpe pipe will be provided as free issue material.

- 5.1.10 Replacement/Repairing/Modification/Shifting/housekeeping of SR / PE Valve Chamber/ PE Ball Valve/Meter / regulator / any other components of the downstream of DRS/DCU network, providing Valve Chamber covers as and when required.
- 5.1.11 Providing assistance to HPOIL GAS during major gas supply curtailment/other supply interruption.
- 5.1.12 For Part 1 i.e. SOR line items 1 to 13 all size of PE pipes, GI Pipe, Isolation valves, Appliance valves, PE ball valves, domestic gas meters, meter regulator, service regulators shall be supplied by owner whereas rest of the materials such as GI/PE fittings, Rubber hose Pipe, warning tape, clamps or any other fittings not mentioned here but required to perform task can be claimed through SOR. All materials which are to be supplied by bidder shall be as per technical specifications of HPOIL GAS and before using at site, shall be inspected/approved by HPOIL GAS team.
- 5.1.13 All tools-tackles required to carry out above mentioned services are in scope of bidder & supply of consumables like Teflon tapes, grease, lubricant, rust removals, cotton waste, cleaning materials, acetone, screws, nut-bolts etc. as per direction of HPOIL GAS EIC is in bidder's scope services.
- 5.1.14 Health, Safety and Environment compliance in accordance to HPOIL GAS requirements shall be a part of the responsibility of the Bidder.
- 5.1.15 Reporting Management Information System (MIS) to HPOIL GAS EIC / HPOIL GAS O & M team. Collection of data and operational parameters and reporting to HPOIL GAS as per management information system (MIS) and communication systems / training to AEO Team including operational software as directed by HPOIL GAS EIC.
- 5.1.16 Collection, recording of hazardous / non-hazardous waste deposition of the quantity to HPOIL GAS stores / HPOIL GAS authorized waste disposal agency and submit records. Disposal shall be as per HPOIL GAS Standard Operating Procedures.
- 5.1.17 Bidder shall also be responsible for coordination with local government/semi government/private agencies/ other utilities agencies/ Police, Fire Brigade and hospital / dispensaries and provision of ambulance/fire brigade as and when required. Coordination with utility agencies/government bodies/third party agencies for their day-to-day activities for minimizing damages of our underground pipeline by their excavation work along the route of our PE network, Carry out joint survey between HPOIL GAS and Third-Party utility agencies for third party excavation / construction work co-ordination.
- 5.1.18 Cleaning & maintenance of SV chambers.
- 5.1.19 Witness commissioning of various PE-PNG project activities.

- 5.1.20 Preventive maintenance of PE network such as PE pipeline network patrolling, Lock Pressure Test (LPT) / Leak Detection Test (LDT) of network, Isolation, Venting, Repair of network.
- 5.1.21 Preventive maintenance of Service regulators which includes general maintenance of whole installation including painting, testing of OPSO/UPSO, housekeeping in and around service regulators, leak detection and rectification, monitoring of inlet/outlet pressure, sand filling in service regulator foundation, repairing of foundation, replacement of SR Box and other required fitting if necessary.
- 5.1.22 Preventive maintenance of PE ball valves and valve chambers including PE ball valve operation check, Valve chamber cleaning and maintenance including painting/whitewash/housekeeping, replacement of damaged cover plates & pest control for rat and snake repellent (Post Monsoon).
- 5.1.23 Monitoring of pressure and flow at DRS/DCU units based on Owner's requirement.
- 5.1.24 Support services during any other maintenance / shutdown activities taken up by other Agency in area.
- 5.1.25 Shifting / replacement of existing PE line as per instruction of HPOIL GAS EIC (if laying exceeds 3 mtrs then the contractor shall be paid as per SOR Part-II).
- 5.1.26 Sniff test for checking odorant level.
- 5.1.27 Civil works as per HPOIL GAS requirement for which payment will be made as per the rate quoted in the SOR.
- 5.1.28 Any other activities related to O&M and not mentioned in Part-II of this document.
- 5.1.29 Capturing CP readings, monitoring and maintenance of all Steel Network assets including cleaning & maintenance of SV chambers, FT chambers etc.
- 5.1.30 Capturing readings & circulating commercial & industrial bills to customers without any cost to HPOIL Gas, the rates shall be inclusive in supply of AEO team. HOGPL will provide Bills.
- 5.2 Bidder shall deploy necessary personnel on round the clock basis in order to attend emergency complaints within the stipulated response time as per the SLAs defined in this document for all the installations / equipment / associated facilities / uninterrupted consumer services at the direction of HPOIL GAS Representative & by applying best engineering practices, so that the facility runs most economically and efficiently without adversely affecting the life of the facility with due adherence of HSE aspects, PNGRB T4S regulations and statutory compliance thereof.
- 5.3 The scope also covers the supply of services as and when required by HPOIL GAS and as described below for which payment will be made as per the rate quoted in the SOR.
  - 5.5.6 Hiring of JCB, Hydra, Crane, Concrete/Rock breaker, Air compressor, Dewatering pump, DG Set etc. as per instructions of HPOIL GAS EIC. Deployment shall be done within two hours after receiving intimation from HPOIL GAS EIC.
  - 5.5.7 Supply of Unskilled labors shall be done within three hours after receiving intimation from HPOIL GAS EIC.
- 5.4 Operation Management
  - 5.4.1 Bidder shall provide manpower in three shifts for maintenance of Steel & MDPE network on round the clock basis to perform maintenance, planning, scheduling, progress monitoring, coordination, documents management including drawings / sketch / work permit etc.
  - 5.4.2 Bidder shall attend Weekly / Monthly review meetings and all other meetings called by HPOIL GAS and submit monthly summary & performance review to HPOIL GAS.
  - 5.4.3 Bidder shall provide relevant training to the personnel deployed for the maintenance of PNG Network (Steel, PE & GI) including PE Distribution mains & services (GI installation, Gas Meter & Regulator, other accessories), service regulator, MRS, Interconnecting Piping /Tubing, Valves, Fittings, associated facilities and accessories. The training should be exhaustive and including various job skills and HSE management, especially on job and off job safety, emergency handling, disaster / risk management etc. Training records shall be submitted to

HPOIL GAS EIC for review.

- 5.4.4 Local and Statutory Liasoning for emergency work/ installation / shifting of PE Pipeline/valve chambers/Service regulators module/route marker along roads or inside society premises and or shifting of service regulator box shall be under the scope of bidder, however HPOIL GAS shall assist bidder in every possible manner. No separate liaison charges with local authorities shall be paid to the bidder.
  - 5.4.5 Bidder shall acquire necessary documents as per HPOIL GAS requirement before the start of the contract and submit a copy to HPOIL GAS.
  - 5.4.6 Bidder shall perform functional testing of repaired PE / GI network and associated equipment as per approved operating conditions before taking into service.
  - 5.4.7 Bidder shall maintain all O&M related documentation in line with company requirement as per instruction of HPOIL GAS.
  - 5.4.8 Bidder shall co-ordinate with Statutory, Local authorities, utility agency, third Party excavation agency, other Service Provider etc. as per instruction of HPOIL GAS.
  - 5.4.9 Bidder shall adhere to implement Health, Safety and Environment (HSE), Emergency handling & Security Management for the entire operations as per the specification of this document.
  - 5.4.10 Bidder shall ensure the safety of Man and Machine at all the times. The bidder shall remain at all times liable to HPOIL GAS for any loss or damage caused to any building, plant, machine, installations of HPOIL GAS / Consumers/public at large due to carelessness, negligence, inexperienced act of default of the bidder, his agents, representative or employees. HPOIL GAS shall be the sole judge as regards the quantum of loss or damage and shall be deducted from the amount of payable hereunder to the bidder the cost of repairs or the amount of loss or damages. The bidder shall maintain minimum stock of materials all the time during contract period as mentioned in "minimum materials to be maintained in emergency vehicle and bidder's store" but not limited to it. Quantities/materials mentioned in minimum requirement which is to be maintained and may change as per site requirement. Refer Annexure 7.
  - 5.4.11 For SOR line items 1 to 13 all size of GI pipes, PE pipes, Isolation valves, Appliance valves, PE ball valves, domestic gas meters, domestic meter regulators, service regulators shall be supplied by owner. Whereas rest of the materials such as GI/PE fittings, clamps or any other fittings not mentioned here but required to perform task be claimed through SOR. All materials which are to be supplied by bidder shall be as per technical specifications of HPOIL GAS and before using at site, shall be inspected/approved by HPOIL GAS team. Further, the bidder shall maintain proper documentation of stocks and receipt. Please refer Annexure-7 detail list of items.
  - 5.4.12 Bidder shall ensure calibration of all equipment from time to time and maintain the same in best working condition and shall present to HPOIL GAS representative as and when required.
  - 5.4.13 Bidder shall make his own arrangement to provide all facilities like Accommodation and Transport, Canteen, Tea / Refreshments, Food, drinking water etc. to his employees.
  - 5.4.14 Bidder shall not carry out any business at the premises / establishment / consumer base of the HPOIL GAS other than that mentioned in the Bid. Bidder will safeguard the HPOIL GAS's property, and any damage will have to be reimbursed to the HPOIL GAS.
- 5.5 Administrative Management:
- 5.5.1 Bidder shall establish Area Emergency Office as per clause no. 6.1.6, provide adequate office space with seating arrangements and required furniture / office equipment. Total office space and storage of materials should be of 750 Sq Feet and shall consist of minimum space to accommodate change room, Separate Toilets facility for Ladies & Gents & storeroom for materials, emergency spares, tools & tackles with dedicated space for emergency vehicle.

This office should have separate partitioned work stations with necessary facilities for HOGPL Engineers & Area Incharge. Also, MINI AEO Office shall have same setup as AEO Office and shall have the Minimum Area of 250 Sq. Ft along with Basic facilities.

- 5.5.2 Bidder should have their office (AEO office/MINI AEO office) equipped with computer, printer, scanner, required stationeries (all Stationaries viz Paper, logbook, note book, pens, pencils, files etc on scope of Bidder), telephone / mobile, internet facility, cupboards, racks for stacking materials, notice board, white board, CGD network drawing (which shall be updated on timely basis), other consumables etc.
  - 5.5.3 The office (AEO office/MINI AEO office) shall be manned accordingly for shift operations, emergency handling of complaints, preventive maintenance, breakdown maintenance and other O&M functions as required for MDPE / Steel / GI network for piped gas distribution system.
  - 5.5.4 Bidder shall provide emergency vehicle (Four-wheeler as per bid requirement) for attending emergency maintenance, customer complaints, site work prescribed in the scope of work including driver, fuel, preventive/ breakdown maintenance of vehicle. This vehicle shall be equipped with required tools and tackles (under Bidder's scope), mobile phones, public address system. HPOIL GAS will provide UHF wireless communication equipment. Any cost towards repair of vehicle in case of any breakdown / accident shall be borne by the bidder including insurance claims.
  - 5.5.5 Bidder shall also provide Two-Wheeler for attending line patrolling, emergency maintenance, customer complaints, site work as prescribed in the scope of work including fuel & maintenance charges in case emergency vehicle is engaged on duty and as per direction of HPOIL GAS EIC. The Two-wheeler shall be of 2024 model or latest at the time of deputation and shall have provision of carrying toolbox with basic tools. Separate charges will be paid for deploying Two-Wheeler as per the rate quoted in the S.O.R.
  - 5.5.6 Bidder must provide Uniforms, ID cards (mentioning "Authorized to work on behalf of HPOIL GAS.") and Personal Protective Equipment like hard hat as per BS EN 397 / IS 2925, Safety glasses/goggles as per BS 7028 / BS EN 166 - 167 - 168 GRADE 2 IMPACT /IS 8520, High visibility reflective Vest, Safety Shoes as per BS EN 345 / IS 10667 and ear muffs to all his employees. No employee shall be allowed to work without uniform & PPEs. The bidder shall obtain prior approval of HPOIL GAS for the design and color code of the uniforms.
  - 5.5.7 Bidder shall ensure proper upkeep of utility system / services such as, Emergency Vehicle, Tools & Tackles / Materials, Water tanks, Drinking water, other accessories, etc.
  - 5.5.8 Bidder shall provide stationery materials at office at its own cost, but not limited to; Logbook, Registers, Files, Note Book / Pad, Eraser / Ink, Sketch Pens, Tag / Stickers, Stamp Pad, Envelope, Rubber Band, Staplers / Staples, Punch, Pen, Pencil, Refill, Highlighters, Photocopy / Xerox, B&W/Color Printer/Scanner, etc.
  - 5.5.9 In case HOGPL comes up with it's own AEO office in near future, contractor/vendor has to shift within 1 month of time period to the desired setup upon notice/advised by HOGPL at his/her own cost. HOGPL shall not be liable for any dues/disputes arising from existing rented AEO office as offered in this contract. Once the office is shifted vendor shall not raise any bills/claims against the line item.
  - 5.5.10 Bidder shall be responsible to acquire and hold adequate quantities of Materials/Spares / Consumables / Tools & Tackles. (Annexure-5).
- 5.6 House Keeping:
- 5.6.1 Bidder shall be responsible for the house keeping of Equipment / Accessories, Office, Storeroom, Change Room, Washrooms which are under his scope including furnished office on daily basis.
  - 5.6.2 Bidder shall provide housekeeping materials at office / site at his own, but not limited to,

Detergent, Water, Phenyl, Hand Soap, Sanitary Items, Bucket, Cotton Waste, Brooms etc. Disposal of waste material / effluent should be carried out as per the environmental norms. Records of disposal to be maintained for further review.

5.7 Meter Reading & Bill circulation:

- 5.7.1 Bidder shall engage meter readers for capturing domestic meter readings and bill circulation; the meter reader shall be equipped with Bluetooth thermal printers & POS paper Rolls.
- 5.7.2 For Domestic readings, bidder shall engage 1 meter reader for every 1500 customers, total customers expected for next two years are 45,450 Nos. within two years.
- 5.7.3 For I&C customers bidder shall be responsible for capturing readings & circulating commercial & industrial bills to customers without any cost to HPOIL Gas, the rates shall be inclusive in supply of AEO team.

5.8 Communication & Information Technology:

- 5.8.1 Bidder shall provide dedicated smart mobile telephone set (suitable for the region) to its staff for complaint handling and site communication, its tariff charges / maintenance cost shall be borne by the bidder.
- 5.8.2 Bidder shall provide IT related materials at site at his own cost, but not limited to; Desktop, Computer/laptop, Printer, Scanner, CDs, Pen drives, Computer Stationery, Printer Cartridge, etc.
- 5.8.3 Bidder shall upkeep all the data pertaining to O&M and submit the data backup in soft copies as per Owner's requirement.
- 5.8.4 Bidder shall provide internet connection for day-to-day operation / reporting at AEO location.
- 5.8.5 Bidder shall provide the security password given on the system to the HPOIL GAS representative for any official / vigilance objective.
- 5.8.6 Bidder shall provide smart mobile phone at each base for reporting to HPOIL GAS with site related activities (if any).
- 5.8.7 Smartphones shall have HPOIL GAS provided GIS Software installed in it which can be used in case of third-party damages / emergency handling.
- 5.8.8 Bidder shall provide desktop computer/laptop at bidder's office for daily data email communication, report generation and shall have software like SAP, GIS, AutoCAD etc. (installed by HPOIL GAS) installed in it.

5.9 Others / Miscellaneous

- 5.9.1 Bidder shall maintain and upkeep of the facility, emergency vehicle and HPOIL GAS supplied tools & tackles (if any) as per the prescribed HPOIL GAS's requirement.
- 5.9.2 Bidder shall not make any modifications to the facility / premises or without prior approval of HPOIL GAS, in case the office space is provided by HPOIL GAS.
- 5.9.3 Bidder shall be responsible for the security at AEO (including stores for Materials, Consumables & Inventories Storage) and Materials Installations / Equipment, Worksite, HPOIL GAS supplied tools & tackles (if any) etc.
- 5.9.4 Bidder shall ensure and manage the traffic especially vehicular at worksite during the work & in case of emergency as well.
- 5.9.5 Bidder shall intimate to HPOIL GAS for any statutory problem, supply stoppage / interruption,

break down / emergency shutdown etc. for better planning & functioning of the facility.

5.9.6 Bidder shall not entertain any outside person without HPOIL GAS's written permission including Office visit, Photography, Video Shooting or any Interview.

5.9.7 Bidder shall ensure the availability of enough water (Portable / Drinking purpose) at site / office at his cost if required.

5.10 Manpower

Bidder shall deploy adequate number of skilled / unskilled personnel, to carry out the maintenance work & Customer Management for entire AEO Team and Mini AEO Team area effectively in scheduled time, under the scope. No frequent change in the manpower is allowed during tenure of the contract.

**Medical examination:** At the time of joining of his employee, agency shall arrange to produce fitness certificate duly certified from authorized medical practitioner and submit the same to the Company for records. Also, the Agency shall ensure, once a year that the medical examination is done of his employees working in hazardous processes.

**Tentative Minimum Manpower Requirement per AEO Team:**

Category	Minimum Nos. of persons to be deployed per AEO Team in Three Shifts			
	Shift-I	Shift-II	Shift-III	Total
Supervisor	1	1	1	3
PE Technician	1	1	1	3
GI Technician	1	1	1	3
Plumber	2	2	2	6
Helper/Labor	4	4	4	12
<b>Total Manpower in three shifts</b>				<b>27</b>

**Tentative Minimum Manpower Requirement per Mini AEO Team:**

Category	Minimum Nos. of persons to be deployed per AEO Team in General Shift	
	Gen Shift	Total
Supervisor	1	1
PE Technician	1	1
GI Technician	1	1
Plumber	1	1
Helper/Labor	1	1
<b>Total Manpower in General Shift</b>		<b>5</b>

**\*Note- Mini AEO team shall be deployed by bidders in as and when required as instructed by EIC.**

Category	Max. Patrolmen to be deployed for Kolhapur GA.			
	Shift-I	Shift-II	Shift-III	Gen Shift
Patroller for PE Network	6	6	6	-
Patroller for Steel Network	4	4	4	-

**\*Note- Patrolmen shall be deployed by bidders in as and when required as instructed by EIC.**

**Shift Timings as given below or as directed by HPOIL GAS EIC:**

Shift-I - 06:00 to 14:00 Hours  
 Shift-II - 14:00 to 22:00 Hours  
 Shift-III - 22:00 to 06:00 Hours  
 General Shift - 09:00 to 17:30 Hours

Contractor shall ensure that the minimum manpower as per above Table is deployed per AEO team to carry out jobs as defined in this document. Manpower defined in the above table is for reference only and there may be variations as per site experiences and requirement.

**Note:**

- Reliever to the shift personnel to be provided.
- Bidder to prepare monthly shift schedule well in advance and submit for approval of HPOIL GAS. Frequent shift change per person is not allowed.
- Discretion of HPOIL Gas to split offices on basis of network requirement.

**Qualification:** Agency shall arrange the required manpower as per general guidelines, age, academic qualification, experience and specific certificate requirement as mentioned in the below table:

<b>AEO/Mini AEO Team MANPOWER</b>				
<b>Sr. No.</b>	<b>Designation</b>	<b>Experience required</b>	<b>Qualification</b>	<b>Category</b>
1	Supervisor	5 Years of in the field of operation & maintenance of natural gas pipeline (Steel PE/GI/Cu) and resource management	Graduate	Skilled
2	PE Technician	2 to 5 Years of Experience in the field of maintenance of polyethylene etc.	ITI any field /Literate (min. 7 <sup>th</sup> std pass)	Semi -Skilled
3	GI Technician /Plumber	2 to 5 Years Exp. In GI threaded pipeline/GI welded pipeline/Cu Tubing etc. maintenance etc.	ITI any field/ Literate (min. 7 <sup>th</sup> std pass)	Semi -Skilled
4	Helper/Labor	Preferably Literate & Physically Fit	Literate	Un-Skilled
5	Driver	3 Years of Driving Experience with Valid Driving License	Literate (min. 7 <sup>th</sup> std pass)	Un-Skilled

<b>PATROLLER</b>				
1	Patroller	2 Years of Patrolling Exp. with Driving License	Literate	Un-Skilled

<b>ELECTRICIAN</b>				
1	Electrician	2 Years of exp. as electrician	ITI/Diploma	Skilled

- Central Wages shall be applicable, Bidders quoting State wages or wages below the minimum wages will be summarily rejected and such bids will be considered as non-responsive.
- The following components to be considered in arriving unit rate per service:

Item no	COMPONENT	Components To be calculated as mentioned
a	Basic day Wage	=As per Minimum wages Act, 1948 per day w.r.t to its categories
b	EPF	=@ 13% of Basic day wage
c	ESI	=@ 3.25% of Basic day wage
d	Bonus	= (@8.33% of Basic) As per Minimum wages Act, 1948 per day w.r.t to its categories
e	Leave allowance towards one leave for every 20 days of working	=@ 1.525 of one basic wage
f	Contractor service charges	= @

- Any statutory variations in Minimum wages as per Minimum Wages Act 1948 of the labor laws shall be paid to contractor. HPOIL Gas HR Dept. will share Govt notification for revision in minimum wages and same will be circulated with contractor and accordingly HOGPL will modify unit rates in WO after approval. The contractor has to pay the wages as per the notification of government with immediate effect. The contractor can claim the differential amount (if any) on submission of documentary to HPOIL Gas.
  - The Owner shall decide the working hours on the Site and the Contractor shall adhere to it as per General Condition of Contract.
  - Agency employees shall avail leaves, paid holiday, weekly off and other benefit as per prevailing labour laws. For paid holidays and leave, the following provisions to be followed:
    - a) Paid Holiday
      - a. Agency to provide Public Holiday as per Act applicable and ensure its compliance. The applicable Public Holiday is as per the below mentioned table.
    - b) Leave (Privilege Leave)
      - a. Agency to extend Privilege leave to its staff as per Act applicable and ensure its compliance. The applicable Privilege leave is as per the below mentioned table.
- Overtime:** @ double rate to be paid to contract workmen.
- Agency shall ensure that their staff are paid OT as per the rates prevailing in the relevant Acts.

**Detailed Job Description / Responsibilities of Manpower deployed for AEO Team:**

Bidder shall deploy the above specified manpower, with relevant educational qualifications & professional experience in similar field to perform their duties, as described below:

**Supervisor:** O&M Supervisor shall be overall In-charge of entire O&M activities. He shall be qualified Minimum Graduation Level with relevant experience. He will be a coordinator to interact / interface with the OWNER / its representative. O&M Supervisor will be responsible for execution of all relevant work such as Manning / establishment of control room activities, Patrolling & monitoring of Operation, Maintaining Record, Reporting and periodic / emergency maintenance. O&M Supervisor has to ensure the smooth & trouble-free operation of all the equipment, installation & associated facilities, gas supply, administrative functions, HSE, consumer service, Liaisoning, etc includes assisting OWNER in Gas Reconciliation. Also, he shall be responsible for stores / assets management, co- ordination for major job with OWNER / its representatives. O&M Supervisor shall plan all the activities according to approved AOMP (**Annexure-8**) and shall monitor the same. He will be responsible for inventory management, especially for essential spares / assets management. Supervisor will be responsible for supervision, monitoring and execution of day-to-day shift duties effectively pertaining to emergency handling, preventive maintenance of all assets/network as per schedule, consumer complaints / services. Apart from above, he shall be responsible for day-to- day reporting, data logging for the activities performed as per MIS. He shall also be responsible for Liaison with local authorities, etc. He must be competent in maintenance and troubleshooting related to PNG network breakdowns.

**PE Technician:** PE Technician cum plumber shall be responsible for emergency / break down/preventive maintenance/consumer complaints and day- to-day reporting to the Shift In-charge / Supervisor. By regular check, he should ensure working of tools & tackles, essential for his job, similarly should also ensure the availability of minimum stock as per minimum inventory level of each consumable for emergency repair / maintenance. He shall be responsible for the electro fusion jointing of PE pipes for Distribution mains / Services. He is responsible for execution of LPT / LDT and should have good working knowledge on execution of LPT / LDT. He should have relevant work experience and a necessary qualification certificate from a recognized agency for PE welding / Electro fusion. He shall have the trouble shooting knowledge of Electrofusion welding machine / LPT / LDT. He should always carry his competency card and should produce the same on demand and ensure the validity of his competency certificate after attending required training for the same. He should respect / follow the company's guidelines and use the PPEs as per job.

**GI Technician/Plumber:** GI Technician shall be responsible for safe handling of emergency/break down maintenance in response time & must wear all recommended PPEs while on job, for carrying out the leakage test of the facility at the customer's premises as per weekly/monthly plan provided by HPOIL GAS, attending leakage complaints on top most priority and reach the customer's premises within 30 min of reporting, should not collect any cash from the customers under any circumstances., should not enter into arguments with the customer and in case of any dispute report the matter to the Shift In-charge/In-charge immediately and follow instructions/directions given, check for any unauthorized fittings, non-standard hose pipe, damaged hose pipe etc. while carrying out the regular checks/ maintenance and report the matter to Shift In-charge/In-charge and record such details in the service report and obtain customer signature.

**Helper/Labor:** Literate & physically fit helper shall be deployed for the assisting to technician for all activities. He shall be aware of PNG equipment maintenance activities such as MDPE pipeline, SR, Valve Chambers, etc. in case of gas leakage emergency. He shall also assist in initial excavation in case of third- party damage situations and provide assistance to PE Technician for any job pertaining to Maintenance. He shall be responsible for excavation of trenches, pits, cutting of excessive grass / housekeeping in vicinity of SR/TB/DRS/DCU/CPRS/MRS, Valve Pit, etc. in case of gas leakage, emergency. He shall also carry out the housekeeping, office assistance and assistance to Technicians for any job pertaining to Maintenance.

**Driver:** Driver should have necessary valid driving license for driving LMV from regional transport office. He shall be responsible for driving the emergency vehicle in shift operations situated at AEO. He should have basic knowledge of automobile for maintenance. He shall be responsible for driving of vehicle & assistance to technical group in case of any emergency arises. He shall clean & upkeep the vehicle in good working condition. He should ensure the ever readiness of Emergency Vehicle, public announcement system and wireless equipment and mobile phone according to check list on daily basis. Apart from driving of vehicle, he will provide assistance to the team at site and in office.

**Patroller:** He will be responsible for daily patrolling of MDPE & Steel Network. The patroller will start the patrolling in the designated route and carry out a thorough patrolling & checks like Road/ Nalla/ Rail Crossing, Valve-Chamber, Excavation on Pipeline, Gas Leakage if any, condition of Markers etc. during the patrolling, In case of any observation is mentioned &/or narrated by the patroller, then the Supervisor along with the HPOIL GAS engineer must immediately rush to the site of the vulnerable location to confirm the third-party activity. The vulnerable location format shall be filled by the patroller/ supervisor & shall be submitted to the O&M in-charge of the respective site. The filled-up format after site visit & review shall be submitted to HPOIL GAS engineer.

#### 5.11 General Information

Apart from specific job-related responsibilities and requirements, there are certain general rule and regulations that must be followed by all working persons of Bidder as follows:

- 5.11.1 Smoking is strictly prohibited and use of any match, lighter or other means of producing, flames, spark or articles of similar nature is prohibited, at office, everywhere on gas network and installations of HPOIL GAS.
- 5.11.2 Report promptly any situation affecting the safety of self or fellow employees or property and public in general.

- 5.11.3 Employees should train themselves to be on the lookout for regulatory safety signs and should observe them all the time.
- 5.11.4 Any person sustaining an injury on the job, no matter how small, should report for first aid / medical treatment.
- 5.11.5 Horseplay or fooling around while on duty is strictly forbidden.
- 5.11.6 Jumping on or off the Emergency Vehicle is prohibited. Employees should wait until vehicle stop before attempting to board or alight.
- 5.11.7 Employees must stay within their working zone and shall not roam around the other installation of or any other area.
- 5.11.8 Running, jumping or throwing material on job site is prohibited.
- 5.11.9 Where walkways are provided use them. Don't use short cuts.
- 5.11.10 Drive cautiously near the gas installation and gas rich area. Stick to speed limits and other instructions e.g. No parking Vehicle Entry Prohibited, etc. vehicles shall be parked in parking places only.
- 5.11.11 Personnel doing hot job or working near open fire shall not wear clothes made of highly combustible synthetic fibers such as nylons, polyesters etc.
- 5.11.12 Wearing of jewelry ornaments should be avoided while working at site.
- 5.11.13 Only authorized persons may turn valves or operate any equipment or machinery on any installation.
- 5.11.14 No employees should interfere with, remove, displace, damage or destroy any safety devices or other appliances installed for protection of personnel and plant equipment.
- 5.11.15 Cleanliness is necessary for a safe work practice. Wastage like used papers, plastic etc. should be deposited in proper receptacles.
- 5.11.16 Every employee should study safety orders thoroughly and make proper use of all safety devices and equipment furnished for his protection and the protection of others.
- 5.11.17 Every employee must familiarize himself with location and usage of safety devices and firefighting system.
- 5.11.18 Be sure you understand emergency instructions. Anticipate what you will do in case of emergency.
- 5.11.19 Transportation of manpower through JCB, Hydra, Air compressor machine vehicle is strictly prohibited.

## 5.12 Detailed activity details

### 5.12.1 Complaint handling / Emergency response / Network damage repair

The requirement stipulated in this clause shall supplement the requirement of customer services, where different type of complaint arises looking to the various customer aspects. Generally, complaints/service requests shall be observed, as described below:

- Gas Leakage / Gas Smell / Gas Escape / Fire
- Connection Verification by AEO Team.
- Gas Supply Stoppage
- Low Pressure / High pressure conditions
- Meter Not Working
- Meter Replacement
- Temporary Disconnection
- Permanent Disconnection
- Reconnection
- Billing related
- Refitting/fixing of RCC guard
- Any other type (Not mentioned above)

### 5.12.2 Activity Steps for Leak Survey

- 5.12.2.1 To prepare annual and monthly leak survey plan for covering the whole network in line with the annual maintenance plan for actual execution.
- 5.12.2.2 For planned Leak Survey, to decide the network leak survey area and frequency based on the experience and records, post LPT data, criticality of network, activities carried out by other utilities.
- 5.12.2.3 To identify the person and train / educate them for network geography, effective leak survey procedure, emergency communication for heavy leakage and

- preparing report & record.
- 5.12.2.4 To carry out emergency leak survey for the section / network vulnerable to damage due to sudden development / construction activities by other utilities / government agencies.
  - 5.12.2.5 To ensure that the gas detector which can measure gas in ppm level is working, calibrated & with fully charged batteries. To keep the spare batteries depending on the job to be carried out. Calibration certificate to be produced as and when required.
  - 5.12.2.6 To wear PPEs like safety shoes, cotton dress, reflective jacket & I-card and ensure your personal safety from vehicle and building under construction, electrical installations etc.
  - 5.12.2.7 If leak is observed during LPT, then to carry out leak survey by walking along the pipeline route as per as-built drawing, markers and valve chamber position with gas detector keeping probe just 2" above the ground.
  - 5.12.2.8 To observe / hear the detector findings carefully and record the same.
  - 5.12.2.9 To monitor the gas leak in drainage manhole or other such chambers, also survey surrounding area, manholes for measuring extent of leakage.
  - 5.12.2.10 To record the leak % and area / location of leak and to prepare survey report in standard format.
  - 5.12.2.11 Rectify the leakage if any observed during this activity.
- 5.12.3 General Guidelines for Emergency / Breakdown / Shutdown Activities
- 5.12.3.1 The damages & leakages shall be first attended by squeezing the pipelines and in case of unsafe conditions as per the assessment of AEO Team in charges, pipeline network shall be isolated through Isolation valves.
  - 5.12.3.2 Bidder's personnel should be well experienced and trained to handle the emergency maintenance of natural gas distribution pipelines (mains and services lines). They should always be very much vigilant in monitoring the process condition on field instrument and they should be very much open to any calls / information from field personnel natural gas consumers or any third parties relating to any emergency of major leak, damage of pipeline or fire / explosion in the pipelines gas distribution system.
  - 5.12.3.3 In case of any accident on CGD Network or at the consumer's premises, the site supervisors / technicians should immediately rush to the affected site, assess the situation, coordinate with HPOIL GAS. They should close / shut off the upstream isolation valve / control valve installed on the network or from CGS / DRS /DCU/ SR if required. Use of CGS/DRS/DCU valves shall not be done without consent from HPOIL GAS EIC.
  - 5.12.3.4 Bidder shall also be responsible for coordination with local government/semi government/private agencies/ other utilities agencies/ Police, Fire Brigade and hospital / dispensaries etc. for emergency/ breakdown help / rescue.
  - 5.12.3.5 Coordination with hospital/dispensary and provision of ambulance/fire brigade as and when required.
  - 5.12.3.6 Bidder shall train their personnel as per HPOIL GAS guidelines for handling emergencies.
  - 5.12.3.7 Bidder shall plan bi-monthly meeting for improvements / suggestions through learning from
  - 5.12.3.8 experiences. This meeting will also be attended by HPOIL GAS representatives / coordinator.
  - 5.12.3.9 for review of emergency handling / management.
  - 5.12.3.10 Bidder shall shut down the pipeline inlet system at isolation valves of all stations in case of fire and major gas leak, excess odorant smell, stoppage of supply from gas source or supplier. However, HPOIL GAS shall be consulted in such shut down / emergency.
  - 5.12.3.11 Bidder shall not neglect even a small leak, if detected. He shall immediately act upon to check / arrest the leak, which may result into disaster, if the gas catches fire. In case of heavy leakage or burst pipes the exposed gas jet becomes potentially hazardous; hence, the area should be isolated, vent safely and replace the affected portion of the affected area. They should also inform to all the

- concerned.
- 5.12.3.12 Bidder shall be very much vigilant in monitoring this type of situation. If this kind of situation arises then bidder shall inform to HPOIL GAS. Only one thing must be kept in mind while taking any emergency action that human life has the topmost priority, followed by safety of the permanent installation.
  - 5.12.3.13 Bidder Maintenance team member should immediately inform to the responsible authorities (Bidder's or HPOIL GAS's representative, Police, Fire Brigade, etc....) to take immediate and proper action to control the emergency accident hazard / fire and save man and machine / gas distribution pipelines, and public utilities in vicinity of the affected area.
  - 5.12.3.14 The bidder shall prepare call note for each complaint, which will be kept & preserved as record.
  - 5.12.3.15 In case of excess odorization / dosing, action shall be initiated as per the plan by bidder's personnel, includes effective public / mass announcement, control of situation, safe venting of gas, attending consumer complaints door to door.
  - 5.12.3.16 In case of power failure, the bidder 's personnel should ensure alternate arrangement of power supply at site, if required. However, for HPOIL GAS's premises, this should be solved in coordination with HPOIL GAS or its representative.
- 5.12.4 Procedure for attending Gas Leakage / Gas Escape on PE & GI/Cu distribution network:
- Handling gas leak / network damage is the activity carried out quickly and safely arresting the gas leak or pipe damage and restoration of gas supply to the customers. The gas leak on the underground network poses the potential hazard of asphyxiation / fire / explosion and environmental concern. Hence timely and safely attending the gas leak and restoration of gas supply to the customers are very important tasks as it has direct effect on company's reputation, operation, safety, quality, production, customer satisfaction and environment.
- 5.12.4.1 General Instructions while handling Gas Leakage / Gas Escape.
  - 5.12.4.2 Bidder shall take care to prevent damage to other underground utilities like telephone/mobile cables, other gas/fuel pipelines, water lines, electricity and all cables, other pipes, ducts, drains and tunnels whatsoever. Bidder will at his own cost repair or replace damaged portion of utility or pay to concerned department for getting it repaired, in the event of any damage caused by the bidder.
  - 5.12.4.3 Bidder shall use mechanical excavators for excavating trenches only in consultation with HPOIL GAS EIC. This will not relieve the bidder from responsibility for any type of damage to existing services.
  - 5.12.4.4 Any complaint regarding network damage must be repaired as per HPOIL GAS SLA, failing which, HPOIL GAS has right to impose penalty as defined in this document. - Annexure-1
  - 5.12.4.5 All topsoil, road metal or other surface material and hard-core shall be kept separate from other excavated material over the width of the trench and good soil should be uses for back- filling over the pipeline (i.e. without any stone pieces, brick, garbage, sharp edged particles, etc.). Maximum possible care should be taken while backfilling the trench over the pipeline. The pipeline should not have any tension while back-filling. Also, ensure warning tape is put over the pipeline.
  - 5.12.4.6 Bidder shall obtain permit for maintenance work in government/Townships, Consumer premises and Commercial establishments prior to start of work.
- 5.12.5 Complaints
- 5.12.5.1 Related to Network, PNG Installation inside consumer premises, i.e. gas leakages in underground/ above ground pipeline / installations / equipment, valve chambers, No Gas / Stoppage of supply, fire & explosion, etc.
  - 5.12.5.2 Gas smell in kitchen / house, volunteered dis-connection, re-connection, No Flame (Under Pressure), High flame (Over pressure), Meter malfunctioning or showing incorrect value, emergency call etc.
  - 5.12.5.3 Proper guidance to be given to consumer for complaints related to stove/burner/conversion.

- 5.12.5.4 Complaint handling for fast meter, meter not running, and meter replacement & meter recalibration also is in the scope of bidder.
- 5.12.5.5 Complaint handling for Fixing/refitting/replacement of RCC guards
- 5.12.5.6 Bidder must give priority in following sequence: Fire & Explosion>Gas Escape>Gas Supply Interruption > Other Category of consumer complaints as per SLA > Routine or Periodic O&M.
- 5.12.5.7 Emergency response / Complaint handling will be done as per HPOIL GAS Guidelines.
- 5.12.5.8 Bidder shall strictly follow the HPOIL GAS procedure while handling complaints.
- 5.12.5.9 Complaint handling for billing related queries.

#### 5.12.6 **Disconnection / Re-Connection**

Bidder shall be responsible for disconnection and re-connection procedure of all PNG consumers (Domestic /Commercial / Industrial). However, it should be performed in consultation with the HPOIL GAS / its representative.

5.12.6.1 **Disconnection:**  
Disconnection procedure can be categorized into following types. Bidder shall carry out following activities:

5.12.6.1.1 **Temporary Disconnection:**

- Bidder personnel shall receive the consumer application form from HPOIL GAS's representative. After receiving temporary disconnection request, bidder shall send AEO team for physical disconnection. On completion of Temporary disconnection as per the instructions of HPOIL GAS EIC, submit the document to HPOIL GAS EIC confirming the disconnection to update the details in billing software.
- Bidder's team on successful disconnection shall intimate / provide the details to billing personnel for necessary entry / update in the billing software. The response time for this activity shall be fixed by the HPOIL GAS SLA.

5.12.6.1.2 **Temporary Disconnection (Dunning)**

Temporary disconnection shall be carried out in following cases.

- Non-payment of gas consumption bill as per HPOIL GAS's Policy.
- Non-payment of installation cost, penalty for various reasons.
- Using gas with unsafe installation / circumstances or tampering / manipulation of installation / equipment or for any other technical / non-technical reason.

This activity shall be carried out in close consultation with HPOIL GAS / its representative. After successfully carrying out such disconnection, necessary report / updating in billing software/ MIS shall be made. The charges and modus-operandi shall be decided by HPOIL GAS.

5.12.6.1.3 **Permanent Disconnection**

- Bidder personnel shall receive request for permanent disconnection from HPOIL GAS's representative. Bidder shall send AEO team for physical disconnection. On completion of Permanent Disconnection as per the instructions of HPOIL GAS EIC, submit the document to HPOIL GAS EIC confirming the Permanent disconnection to update the details in billing software.
- Bidder shall disconnect the connection & disconnected materials i.e. GI pipes & Fittings, Domestic meter & regulator, Ball Valve & Gas Tap etc. shall be recovered from site & handed over to HPOIL GAS's representative.
- Bidder's team on successful disconnection shall intimate / provide the details to billing personnel for necessary entry / update in the billing software.

5.12.6.2 **Re-Connection:**

- On receipt of consumer request for re-connection, bidder shall send AEO team for reconnection.
- Bidder's technician, on successful re-connection shall intimate / provide the details to billing personnel for necessary entry / update in the billing software

to enable to issue the bill to the respective consumer.

#### 5.13 Patrolling of Distribution / Service Line (To be done under scope of Part-I)

- Bidder shall provide two-wheeler vehicle (model 2024 or latest min. 100 CC) including Fuel, VTS and other consumable for average running of 3,000 KMs per month. Same will be reconciled in every 3 months and the extra KM beyond 9,000 kms can be claimed as per SOR no 1.11. Necessary PPEs to be provided. Bidder shall provide 01 patrolmen along with two-wheeler vehicle.
- On receipt of O&M contract, BIDDER shall take specification / detail of Steel & PE distribution network, as-built drawings, testing reports and other construction records from OWNER.
- The villagers / public along the right of way shall be adequately made aware of the possible consequence of gas leaks and this shall be included as a part of the regular audit.
- BIDDER shall visit the overall site along with related staff members to make themselves aware about route, type of laying, special crossing, and size of pipeline.
- BIDDER shall take As built drawings / schematic etc of network from OWNER or from its contractor in soft copy and shall be updated regularly with repairs / modifications carried out over the time period
- BIDDER shall identify Emergency and interconnection valve chambers in consultation with OWNER as per requirement of flow curtailment / emergency stoppage of Gas supply. Emergency vehicle shall be equipped with all necessary valve keys to operate valves, pipe piece for leverage, leak clamps, tools tackles and consumables to handle the gas leak or fire emergency on gas network.
- Based on the findings of monitoring and patrolling activities, necessary actions BIDDER shall plan in consultation with OWNER and same shall be implemented / executed to maintain the overall safety and integrity of network.
- In case of breakdown of valve chamber or valve of PE, BIDDER shall repair / recondition.
- BIDDER shall arrange patrolling staff to inspect the areas of construction activities & physical deterioration if any of exposed pipes and supports, which could cause damage to the pipe & result in gas leakage & subsequent hazard to public safety.
- BIDDER shall divide the total network route in sub-route / section such that total network can be patrolled as per the instruction of OWNER EIC.
- Maintenance team members shall inspect pipeline at critical sections / locations / chainage, such as rail crossing, waterways road crossing, etc. at periodicity advised by OWNER EIC in order to ensure good, no leaks condition, general construction activity, or any other factors, which may affect the safe / uninterrupted operation of gas distribution system.
- BIDDER shall depute manpower separately as advised by OWNER EIC in order to safeguard gas pipeline against any kind of third-party excavation threat & other utility / ROW work.
- BIDDER shall ensure that all patrollers must have Android phone with working internet connection, patrollers must use HPOIL's patrolling mobile app for tracking and incident reporting, no separate charges will be paid for Mobile phone and recharges, these prices are inclusive in Patrolling service line item.
- BIDDER's scope shall also include patrolling of PE/Steel Pipeline / Distribution Mains (network) for entire CGD network established in various villages / townships, main roads including MP and LP Pipelines.

##### 5.13.1 Activity Steps for Patrolling:

- For planned patrol, to decide the network patrolling area and frequency based on the past experience and records, criticality of network, activities carried out by other utilities. Monthly planned patrolling need to be carried of MP -PE network. And additional patrolling shall be carried out based on need based.
- To collect commercial and industrial meter readings on daily basis and sharing the same with CRM team.
- To prepare the annual and monthly patrol plan for actual execution.
- To identify the person and train / educate them for network geography, effective patrolling procedure, emergency communication for leakage and preparing report & record
- To carry out emergency patrol, for the section / network vulnerable to damage due to

sudden development of activities by other utilities.

- To check the condition of vehicle like, fuel, tyre pressure, breaks, light, oil level, side light etc. before starting patrolling
- To ensure availability of drinking water, first aid and other specific requirement if any
- To wear PPEs like safety shoes, cotton dress and reflective jacket
- To carry out patrolling by driving the vehicle along the pipeline route, as per, as-built drawing, markers and valve chamber position, observing activities on pipeline as per check list, like excavation, construction, encroachment,
- To coordinate and monitor with external agencies working on charged network of OWNER as per permissions issued on pipeline route.
- To understand their work, extent of excavation and its potential hazard to underground gas pipeline
- To explain them, about the gas pipeline network / route and precautions to be taken to prevent damage to gas pipelines.
- To provide / update them with contact number and other details of OWNER's authorized EIC for assistance.
- To collect details of their supervisor like contact number, address etc for further coordination.
- To prepare report in standard format and submit to HPOIL GAS Representative as per predefined frequency.

#### 5.13.2 Others

5.13.3.1 The purpose of extending consumer services & complaints handling is to manage / facilitate the day-to-day operations in such a way to enhance the satisfaction of PNG consumer at optimal level with due adherence of HSE / Statutory aspects, which will be related to technical & non-technical issues.

5.13.3.2 The services & Complaints shall be handled as per the Service Levels Agreement and shall be responsible for achieving targets / Benchmarks set in Management Plans specified by HPOIL GAS.

5.13.3.3 In addition, bidder shall install route markers, PE ball valves, valve chambers, service regulators, help in resetting of network assets i.e. SR, flushing and purging, witness commissioning activities of various assets in AEO boundary, capture and maintain GIS co- ordinates, Sniff test for measuring Odor Level as per HPOIL GAS requirement.

5.13.3.4 Bidder shall carry out preventive maintenance of Service Regulators / Riser regulators, PE Ball Valves / Valve Chambers, MDPE Patrolling, Walk-In survey of MDPE network, LPT of Secondary & Tertiary Network, Preventive maintenance of MS Culvert, DRS/DCU Downstream Transition fitting joints, Painting of Assets, consumer connection as per the schedule decided by HPOIL GAS.

5.13.3.5 Bidder shall maintain utility register for communication of various agencies on daily basis, report of Gas Escape / Near Miss / or any other incident shall be reported by the bidder. All reporting formats shall be submitted by the bidder as per HPOIL GAS requirement.

5.13.3.6 Material consumption data shall be provided by bidder to HPOIL GAS on daily basis as per required format.

5.13.3.7 Ensure there is no leakage after job completion. During the execution of work, utmost care must be taken so that no property or part of the property is damaged. If in case the damage is done by whatsoever reason or due to any negligence on your part the damaged property or part of the property shall be repaired / replaced by Bidder. No additional payment shall be done by HPOIL GAS.

5.13.3.8 Bidder has to assist HPOIL GAS for compliances of various internal and external Audits. The Bidder shall carry out work under his scope to ensure that no adverse audit observations are invited. Bidder will also coordinate and cooperate with Audit Agencies during such audits.

#### 5.13.3 Emergency Vehicle:

5.13.4.1 The Emergency Response Vehicle (4-Wheeler) shall be of 2024 model or latest at the time of deputation to be provided by the bidder. The vehicle to be deployed should be CNG/Diesel Fueled standard and established models, 4 + 1 Seater or

- equivalent model complying to BS-VI or latest.
- 5.13.4.2 The vehicle pay load shall be 0.7 to 1 ton and shall be within the GVW of vehicle as declared by manufacturer.
- 5.13.4.3 Standard reasonable load carrying vehicle, with open truck type body and good maneuverability that can be converted into maintenance van, after building customized body for storage and security of various consumable materials, equipment and tools & tackles, pipes and fittings, PPEs, fire extinguishers etc. generally required for handling fire, gas leak / escape emergencies/consumer complaints and routine/break down maintenance of network and installations is also preferred.
- 5.13.4.4 Vehicles shall comply with the existing emission norms for city region, registered in adjoining or operating city areas with valid goods as well as public transport license / permit.
- 5.13.4.5 Bidder shall provide Emergency Vehicle along with accessories and the vehicle shall be used and kept in good working conditions all the time. Driver to be deployed on this vehicle must be well trained / experienced, non- alcoholic & dressed in approved uniform.
- 5.13.4.6 For handling emergency calls and carrying out various planned operation and maintenance activities of the city gas distribution system, availability of well-equipped vehicle called normally as Emergency Vehicle is very important.
- 5.13.4.7 For highlighting the company identity, the Emergency Vehicle shall be painted with HPOIL GAS logo, name, and contact telephone numbers & special color & design approved by HPOIL GAS to ensure it has good aesthetic look.
- 5.13.4.8 Vehicles shall have HPOIL GAS logo on front and side panels and 'EMERGENCY VEHICLE' letters painted in radium as per design and specifications of HPOIL GAS. Obtaining necessary statutory approval for the same if required shall be in the scope of bidder.
- 5.13.4.9 The Emergency Vehicle shall also be fitted with public announcement system and wireless equipment (UHF base station provided by HPOIL GAS). The public announcement system is required for making announcement for stoppage and resumption of gas supply, during pipeline damage / gas escape, or equipment failure and for festival safety. The UHF wireless equipment is for contact with control room from remote areas.
- 5.13.4.10 As stated above, ever readiness of Emergency Vehicle with all required items is very important, and hence should be operated and maintained with utmost care. The vehicle should be used only for intended purpose. The copy of records of the maintenance done shall be submitted along with the bill for that month.
- 5.13.4.11 In case of breakdown, the bidder shall arrange replacement vehicle within 4 hours. The replacement vehicle shall be the same type and construction with valid goods carrier permit. The vehicle shall be in good condition and fit for use. Bidder will shift all tools, materials, PPES & equipment to alternate vehicle without any delay.
- 5.13.4.12 Ensure driving of the Emergency Vehicle with lawful and traffic safety.
- 5.13.4.13 The regular checks and inspection procedure should be established, assigning responsibility to Shift In-Charge. The vehicle should be checked daily in the morning having checks for tyre pressure, engine oil, fuel level, other abnormalities like over temperature, vibration, noise etc. including Public Announcement and Wireless system.
- 5.13.4.14 The Emergency Vehicle should be regularly serviced in a good, equipped garage. Similarly, the tools & tackles should be checked as per HPOIL GAS norms to ensure the availability and working condition of each item. The effective material reconciliation procedure should be followed and check list should be prepared to ensure the availability of pipes and fittings and addition for the consumed pipes and fittings. The replacement for the use / lost items should be done immediately by bidder otherwise there are chances of forgetting the replacement.
- 5.13.4.15 The fire extinguisher, pressure gauges, torches stored in the emergency vehicle, should be periodically checked, and calibrated for their working. For overall security of all items, the Emergency Vehicle should always be locked and

guarded, when not in use.

- 5.13.4.16 At site the Emergency Vehicle should be parked at safe and secured place, keeping watch. Take out the required items only, do not remove / take out unwanted items, from the Emergency Vehicle. Ensure that all equipment returned in the Emergency Vehicle to their respective place, after repeatedly looking outside, here and there.
- 5.13.4.17 Bidder shall maintain the day-to-day records as per MIS & submit it along with monthly reports.
- 5.13.4.18 Vehicle should be maintained in proper working conditions throughout the tenure of the contract by carrying out preventive & breakdown maintenance as per Vehicle Manufacturer's recommendations.
- 5.13.4.19 Bidder shall submit the report on such scheduled or breakdown maintenance performed from time to time. All the inspection & maintenance should be carried out by authorized dealers only.
- 5.13.4.20 Bidder shall make an alternate arrangement in case of Periodic maintenance to be carried out or for RTO purpose, required from time to time at his own cost & risk. Bidder shall ensure that in such case, the services are not affected.
- 5.13.4.21 Any penalty for non-compliance or delay in compliance of statutory matters shall be realized / recovered from bidder.
- 5.13.4.22 Bidder shall ensure the validity of driving license for the drivers deployed on vehicle.
- 5.13.4.23 Bidder shall be solely responsible for any accident of vehicle & caused damages to vehicle or the property of third party or the human (injury or death). Such cost shall be borne by bidder & any complaints in police or competent authorities in this regard shall be taken up at his cost & risk including insurance claim, repairing of vehicle, damage to third party, etc.
- 5.13.4.24 Vehicles shall be fitted with speed controller and retractable seat belts for all passengers.
- 5.13.4.25 Vehicles shall be fitted with the reverse horn & camera system.
- 5.13.4.26 Vehicle shall have provision for generator rack to carry portable diesel generator to work-site.
- 5.13.4.27 The HPOIL Gas Branding as per standard & emergency vehicle shall be written inert color on both side of vehicle. The marking and painting shall be under the scope of contractor without extra cost to HOGPL as per direction of EIC.

An illustrative sketch of an emergency vehicle is attached herewith (prior approval of HPOIL GAS shall be taken before carrying out the modification and branding on the vehicle).

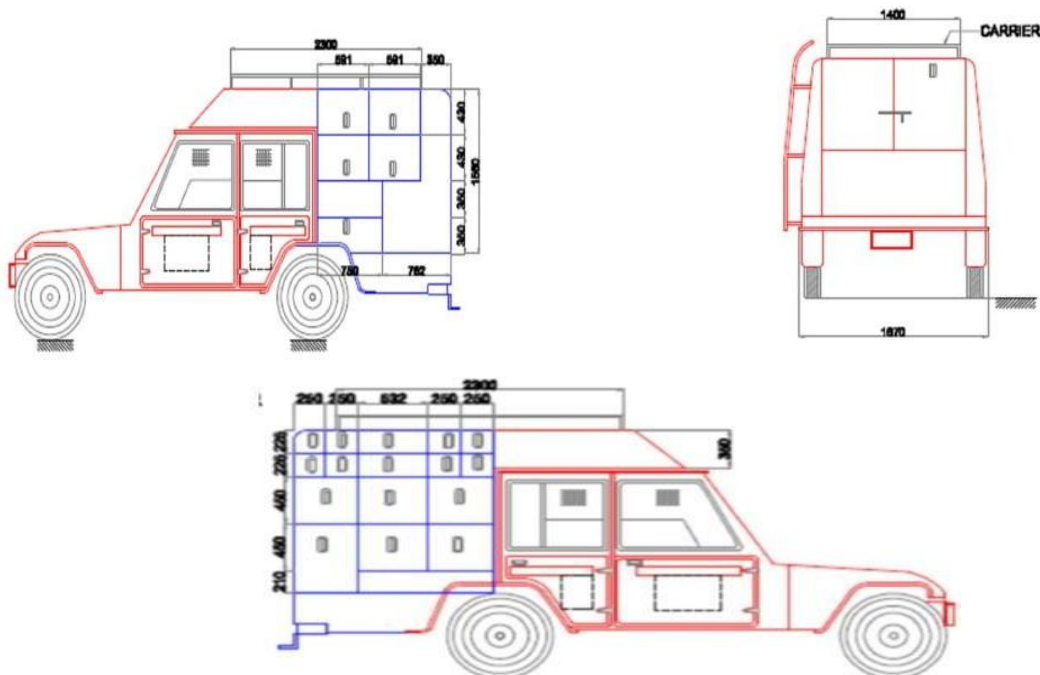

#### 5.13.4 Documentation

The vehicle drivers shall keep the original copies of their licenses with them while driving the vehicles. The vehicle drivers shall ensure that their driving licenses are valid and renewed on time.

The legal documents include:

- Registration Book
- Insurance
- Driver's license
- PUC certificate
- License for wireless device
- Documents related to CNG Kit & cylinder (in case of CNG vehicle)
- Tremcard (Transport Emergency Card), if applicable
- Fitness Certificate issued by Transport Department (RTO).
- Tax certificate

#### 5.13.5 Reporting

Bidder shall be responsible for reporting as per HPOIL GAS's "Management Information System" (MIS). HPOIL GAS shall provide the copy of MIS to the bidder, according to which bidder has to submit the same for perusal & approval of HPOIL GAS. Typically, the bidder shall prepare the following reports but not limited to:

- Bidder shall prepare General Reports regarding the CGD operations in Daily, Weekly or Monthly and submit the same to HPOIL GAS in soft as well as hard copy in the format provided to the bidder.
- The general activity report mainly comprising of Daily Progress Report, PE & PNG Updates, Periodic
  - / Preventive / Breakdown / Shutdown job (if any)
- Customer service call notes, Emergency vehicle records, First-Aid up keeping, Stores and Inventory reports
- Bidder shall follow maintenance plan given by Owner and submit all reports along with supporting documents for the same.
- Bidder shall submit maintenance activity report with reference to the Maintenance plan.
- Bidder shall maintain daily status for the Material In & Out.
- Bidder shall ensure that all Near Misses occurred during execution of the work are reported time to time to HPOIL GAS. Any Hazard spotted while on job shall be reported to HPOIL GAS for further mitigation. Any incident / Accident shall be reported to HPOIL GAS as per guidelines.
- Bidder shall maintain logbook / record of the entire maintenance as well and calibration & testing of equipment and instruments, if any.
- Bidder shall maintain the register for the Attendance of manpower, Fire extinguisher status and submit to HPOIL GAS.
- Bidder shall prepare the detailed inspection and health check-up report for each equipment / installation and submit to HPOIL GAS for perusal.
- Bidder shall maintain the data for Dis-connection, Re-connection etc. & update in HPOIL GAS format / inform to Billing Department for updation.
- Bidder shall prepare the analysis reports related to various activities to enable HPOIL GAS to carry out the predictive actions therein.
- Bidder shall assist HPOIL GAS to prepare statutory or other reports as & when required related to CGD operations.

#### 5.14 Quality Control

5.14.1 The Quality Control indicates the requirement for various activities pertaining to the scope of work. This is a significant requirement to ensure "Safe, Reliable & Uninterrupted" supply of natural gas by delighting customers with due compliance of HSE aspects. Bidder shall follow all HPOIL GAS procedures/quality assurance plans/guidelines.

5.14.2 HPOIL GAS shall carry out the Quality Assurance, periodic safety check and test schedule of all the equipment and instruments at regular intervals, includes inspection of spares, material at factory / site / stores if required.

#### 5.15 Guarantees and warranties: Performance Guarantee of the Work

Bidder shall guarantee the work executed by him for a minimum period of 12 months against poor workmanship, defective equipment and material, etc. If any defects are found during the guarantee period, then the bidder shall rectify the same within shortest possible time, otherwise HPOIL GAS may get the same rectified through other agencies and recover the cost, so incurred from the bidder's deposit against performance guarantee or amount due to the bidder.

#### 5.16 Equipment and Material / Spares Warranty

- All the equipment and materials, if supplied by bidder shall be warranted for trouble free operation for a minimum period of 12 months.
- In case of bought out items, bidder shall obtain such guarantees from the sub-vendor in favor of HPOIL GAS without prejudice to his liability for the performance of whole system including bought out items. Bidder shall intimate to HPOIL GAS for any defect found in the material supplied by HPOIL GAS promptly.
- In case of any problem arising during guarantee period, bidder has to carryout necessary rectification at no extra cost to HPOIL GAS.

#### 5.17 Statutory compliance:

Insurance coverage, compliance with central /state government regulations, compliance with labour regulations, employment of labour and work & safety regulations are as per contract.

#### 5.18 Meter Reading, Bill Circulation for Domestic Connections:

- Bidder shall be responsible for visiting PNG customer premises, capturing readings via smartphone applications, distributing physical or digital bills.
- In case the customer's house is locked bidder shall revisit the house twice at different instances and submit photographic evidence in mobile app post verification by CRM team the bidder shall visit again for circulating the average bill.
- Bidder shall arrange own set up for printing customer list for billing, HOGPL will provide customer list via email only.
- Bidder shall arrange Bluetooth thermal printers and supporting POS rolls at his own cost.
- Bidder shall engage 01 dedicated meter reader & a thermal printer incl. supply of POS paper rolls for every 1500 flame converted connections considering total 45,450 connections till the end of contract (For scope refer Technical Vol. Part I).
- Domestic billing is on monthly basis.

Note: This item is only for Domestic connections, Industrial & Commercial bi-monthly bills circulation will be done by AEO team at no extra cost to HOGPL. I&C Bills will be provided by HOGPL.



## PART II

### 6 DETAILED SCOPE COVERED UNDER PART-II (LINE ITEMS 13-120):

Supply of materials & labor charges for Diversions, Alterations, Modifications, PE Pipeline laying/shifting, Steel Pipeline leak repairs, Installation of Route markers/PE Valves, Construction of Valve Chambers, Preventive Maintenance of Domestic/Commercial/Industrial connections, Civil & other structural works, painting etc. based on request/requirement of Owner. All jobs will be performed as per requirement of T4S & other PNGRB standards and applicable maintenance codes, bidder shall conform to the safety requirements of HPOIL GAS as per site requirements.

\*The rates mentioned in Part II are inclusive of manpower & charges, AEO team shall not be engaged in execution of these activities.

Handling, loading, transportation and unloading of owner supplied MDPE pipes (PE 100, SDR 11), GI Pipes, Service Regulator, Isolation Valves, Meter regulators from owner's designated stock yards/place(s) of issue/dump site(s) along with, contractor supplied materials like PE-100 Electro fusion Fittings like Bends, Couplers, End Caps, Tee, PE Reducer, Rubber Hose, transition fittings, Saddle Tapping, Warning Mats (300mm width x 300 Micron), Casing Pipes, Valve chamber. Supply & installation of Route/Line Marker, riser Guard, GI/Cu fitting for ground connection after verification by OWNER engaged TPA at contractor store which is required to complete the work. Contractor's owned stock-yard(s)/ work shop(s)/ work site(s) including proper storing, stacking, identification, providing security & insurance cover for the materials. Liasoning with Landowning agencies / statutory authorities and obtaining NOC, preparation of Auto Cad for approval of Owner In charge. Trial pits to determine the underground utilities/ services etc., obtaining permission from Land owning agencies , temporary/permanent restoration of the abandoned trial pits as required (excavation to depth as per specification ) to original condition. Barricading the work area as per the procedures & as per the directions of EIC / AIC/ site-in charge. Trenching to the required depth in normal surface/ prepared and unprepared surface (Kutchra surface) terrain, damping, stringing / uncoiling on the pipes in Right-of-Use, jointing of the pipe ends/ fittings/ valves by qualified personnel, using bar coded electro fusion techniques. PPES (i.e. Safety Helmet, Safety Shoes, Safety Glasses, reflected jacket, Coated boring tool and Hand Gloves) shall be used for compliance to safety norms as per Company's requirement. Maintain minimum top cover of 1 m or as per instruction of EIC/AIC. Trenching to all depths by excavation in all types of soils including hard rock blasting, chiseling or otherwise cutting etc. to a width to accommodate the pipeline during lowering & backfilling as per the relevant standards, specifications etc. Permanent restoration by doing Asphaltting, concreting etc. is not covered in the scope of this work. Final clean-up & restoration of right of use/corridor and other associated area to its original condition, including cleaning the area of all unserviceable materials, debris, excess earth near trenches to the designated disposal area area as per the specifications, instruction of Owner/ Engineer-in-charge.

Bidder shall provide services along with materials mentioned under Bidder's scope Part-II based on Owner's request/plan. The following O&M activities shall be covered under part -II of this document.

- Domestic Connections Alterations/Refittings.
- Installation of new PE Ball Valve along with construction of valve chamber
- Shifting/laying of PE pipeline for O&M purpose.
- Laying of PE Service pipeline for connecting Domestic/Industrial/Commercial customers.
- Installation of Service regulators Box along with foundation.
- Installation of route marker
- MRS Shifting of Commercial/Industrial Connection within premises.
- Steel & PE Valve Chamber Cleaning/Maintenance.
- Attend and repair Emergency Leakages in steel Pipeline of 4", 6", 8", 12".
- Relocation/shifting of existing route/pole markers.
- Painting of any surfaces SR Boxes/Valve chamber/route/pole markers, etc. (the contractor shall be paid as per SOR Part-II).



Note: - All activities which are not mentioned in Part-II shall be done under the scope of Part-I and no separate SOR shall be paid to Bidder for it.

All materials for carrying out above-mentioned activities are in Bidder's Scope except GI/PE pipes, PE ball valves (for repair/replacement valve will be provided by HPOIL whereas for new valve installations PE valve shall be supplied by bidder at no extra cost), gas meters, domestic meter regulators, service regulators.

Supply of consumables like Teflon tapes, grease, lubricant, rust removals, cotton waste, cleaning materials, tools and tackles required etc. as per direction of HPOIL GAS representative is in bidder's scope services.

Statutory, Health, Safety and Environment compliance and labour law compliance in accordance as mentioned in tender.

All required materials except GI/PE pipes, domestic, I&C meters & regulators, service regulators, shall be supplied by Bidder and no separate charges will be paid for materials mentioned under bidder's scope.

The bidder shall maintain sufficient stock of all required materials i.e. Owner's provided items such as GI/PE pipes, gas meters, gas meters & regulators, service regulators and Bidder's provided items such as GI/PE fittings, warning mate, brass fittings, etc as instructed by HPOIL GAS representatives. Bidder shall maintain proper documentations and receipts of owner's supplied materials and submit material reconciliation report along with monthly invoice. No separate charges will be paid for materials mentioned under bidder's scope.

Sr. No.	Category/Asset/Equipment	Frequency
1	Domestic Connection Preventive Maintenance	1 Year
2	Domestic Connection Testing & Maintenance	5 Years
3	Industrial Connections Preventive Maintenance	1 Year
4	Commercial Connections Preventive Maintenance	1 Year
5	GI/Riser Approach Maintenance	1 Years
6	Domestic Connections Alterations	Based on request
7	Installation of new PE Ball Valve along with construction of valve chamber	Based on request
8	Shifting/laying of PE pipeline for length more than 3 mtrs for O&M purpose	Based on request
9	Installation of Service regulators Box along with foundation.	Based on request
10	Installation of route marker	Based on request
11	MRS/Meter Shifting of Commercial/Industrial Connection	Based on request

**6.1 Detailed work details which are to be carried out to perform above mentioned activities.**

**6.1.1 Cleaning & Maintenance of Steel Valve chambers.** Removal of all foreign materials like grass, vegetation, garbage, water (by arranging dewatering pump if required), sewage etc. Pest control Treatment in valve chamber such as Limestone powder etc. Checking of Valve Operability & greasing. Rate includes removing and placing cover slabs with tripod chain pulling arrangement if required. This is in addition to routine preventive maintenance of valve, valve chamber by AEO Team.

**6.1.2 Cleaning & Maintenance of MDPE Valve Chambers:** Cleaning & Maintenance of Steel Valve chambers. Removal of all foreign materials like grass, vegetation, garbage, water (by arranging dewatering pump if required), sewage etc. Pest control Treatment in valve chamber such as Limestone powder etc. Checking of Valve Operability, rate includes removing and placing cover slabs with tripod chain pulling arrangement if required. This is in addition to routine preventive maintenance of valve, valve chamber by AEO Team (For scope refer Technical Vol. Part II).



### 6.1.3 Domestic connection testing & maintenance - 1 Year Frequency

Preventive Maintenance of domestic connections shall include following mentioned activities and it is to be ensured that the connections should be included in maintenance plan on annual basis. Record of "Premises locked" & "House under renovation" cases shall be maintained separately & shall be considered in next year.

- Performance Check: - Visual Inspection: Proper Clamping, Proper Alignment, Painting, Condition of pipe/Suraksha Hose, Condition of RCC guard, Meter running or not, Illegal Extension/Modification.
  - Regulator Outlet Pressure through pressure gauge
  - Leakage Check: - Following steps shall be followed to check leakage
  - Leakage from connection- take initial meter reading, hold it for 15 mins and take final meter reading in no consumption status of connection. If any difference in reading, leakage exists.
  - If leakage existing, check every joint using soap solution/GMI and rectify.
  - If leakage is not identified through Soap Solution/GMI method, remove meter assembly and hold pressure of 400 mbar for 15 mins and check every joint using soap solution to identify leakage point.
  - Meter Function check with 2 mins stove – small burner on, if reading is less than 0.004 units than, meter is moving slow and if reading is more than 0.008 units, meter is running fast. Replace meter in any of abnormal case.
  - Replacement of Suraksha Hose.
- Riser Check: Visual Inspection: -Proper Clamping, Proper Alignment, Painting, RCC guard, Illegal Extension/Modification Leakage Check: -
  - Leakage from GI riser/approach shall be checked by holding pressure of 400 mbar for 30 mins from one of the tapping connection or Idle Tee joint left for future tapings & closing of MIV of all tapping connections. If there is difference in pressure during holding period, there is leakage.
  - If leakage found, check each riser/approach joint to identify leakage point using soap solution/Gas Detector.
  - Once leakage point identified, we shall solve by removing /refitting or replacement of leakage piping portion.
  - After Successful repair, repeat step 1 to recheck leak if any.
  - Proper painting, re-installation or replacement of clamps, sand filling in RCC guard, Ball valve condition/function check and proper installation of RIV handle if required also need to be carried out in riser maintenance activities.

Based on observation, all corrective and preventive actions shall be taken such as painting touchup, replacement of clamps, cementing, fixing of RCC guard, replacement of meter/regulators/rubber or any other fittings if required, rectification of leakages, etc.

Note: Only hose pipe, meter, regulator, isolation valve, appliance valve shall be supplied by owner all other materials like GI clamps replacement/screws/ paint touching/ sand filling shall be included in rates quoted by bidder.

### 6.1.4 After Sales Services of Domestic connections/Commercial/Industrial Connection:

After Sales Services shall consists of following service request (Chargeable to the customers) from customer which may include following services request and there shall be defined SLA for each category of service requests. All service requests shall be attended as defined SLA.

- Refitting of connection pipeline
- Modification of pipeline
- Extra Kitchen Point
- Extra Bathroom Point
- Riser Shifting



- Conversion of customer stove after commissioning

**6.1.5 Installation of new PE Ball Valve along with construction of valve chamber**

This includes supply and installation of PE ball valve (63mm/125mm) on charged/uncharged network along with construction of Valve chamber. PE Ball valve & other PE couplers & fittings required for elevation, construction materials for valve chamber construction and other services/materials required to carry out this job shall be under Bidder's Scope.

**6.1.6 Shifting/laying of PE pipeline for O&M purpose [For more than 3 meters of laying]**

This includes trenching, sand bedding, uncoiling, laying of new MDPE pipeline, back filling and restoration of site with supply of electrofusion fittings and warning mate required for carrying out the job. It also included local liaison.

**6.1.7 MDPE Pipe Service Line laying in commissioned areas - For Pipe length upto 5 mtrs:**

I Includes laying of pipeline (for 20& 32mm) in all type of surface i.e Kutcha, metal, concrete (PCC/RCC), bituminous, tiles, brick, land etc. after racking up of hard surface of any type by any methodology, connection of laid pipeline with existing charged line using Saddle/Tee. Roads, Pavement, Footpaths etc shall be restored to original state once the pipeline is laid. Supply & installation of GI Sleeve /Half round Concrete sleeve shall be included in laying rates. Supply & Installation of GI Sleeves 2.5inch NBx300 mm length Half Round Concrete Sleeves for domestic connection, 3inch NBx300mm length GI Sleeve for commercial and industrial installation, Supply & installation of TF & Powder Coated 1/2" GI Pipe i.e. RIV Piece with Isolation Valve (1.5 mtrs length) for Domestic Installation & 1" with isolation valve for Commercial/Industrial Installation. Installation of domestic/commercial/industrial meter. Excavation, breaking through any obstructions, insertion of pipe, sealing the annuls, fixing of the sleeves with concrete mix, preparation of pedestal & restoration of excavated pits within the size of pedestal & restoration of all pits with the laying of 20/32mm as defined and instruction of Owner/Client. No separate charges shall be paid for restoration, scope also includes preparation of detailed route plan, making trial pits to determine the underground utilities/services etc. Obtaining permission from Land owning agencies shall also be in contractors' scope wherever service lines are to be laid after dismantling drain. For Pipe length upto 5 mtrs. Laying beyond 5 mtrs length (if any) will be paid through SOR 19)\* Note: Only MDPE pipe will be provided as free issue material rest all material & fittings are in Bidder's Scope Refer Technical Volume Part II, clause no. 6.1.7 for detailed scope of work. Installation of Service regulators Box along with foundation.

This includes supply and installation of regulators box and civil work for carry out foundation work.

**6.1.8 Installation of route marker**

This includes supply and installation of new route marker as per HPOIL GAS requirement along with civil work/materials.

**6.1.9 Re-Fitting of 1/2" GI Pipe through threaded joints on Customer Request**

Re-Fitting of 1/2" GI Pipe through threaded joints on Customer Request: This SOR is applicable for Re-fitting of LMC connection/GI Pipes, Meter, Regulators, isolation valves shall be supplied by Owner. All other required fittings and consumables are under Bidders scope. Applicable to alteration requirement/request. (Customer Visit Report Required). The rates mentioned in this line item are inclusive of manpower charges, AEO team shall not be engaged in execution of these activities. All rates are inclusive of materials, charges for mobilization for domestic alteration/riser shifting work/Preparation of isometric drawing and necessary reports/services for making holes in brick wall/RCC structure, refitting of meter assembly, colour touch up, at the time of alteration activity, etc. In case of extra pipe required during refitting, GI pipe can be claimed through supply of GI pipe, all required fittings are in bidder scope.



**6.1.10 PD Meter Installation for I&C connections**

Industrial/Commercial Meter Installation: Including Supply & Installation of non domestic meter clamp, 1" isolation valve & 1" NRV with all associated fitting required to connect the meter to customer's piping. Note\* MDPE Pipe, 1" IV & 1"TF are free issue materials whereas CS pipe & NRV shall be payable through supply items sor, all other required fittings & consumables are in bidder's scope.

**6.1.11 MRS/Meter Shifting of Commercial/Industrial Connection**

This includes shifting of MRS of commercial/Industrial connection within company premises and inclusive of all materials except PE pipe.

**6.1.12 Steel Pipeline Leak Repair**

The work include attending pipeline (Steel Pipeline dia 10 / 8 / 6 / 4 -inch) leak repair by type B sleeve welding at designated location/ sites including transportation of of materials (free issue or contractors scope), supply of manpower & machinery, excavation & backfilling, cutting, welding, grinding, beveling, surface preparation, leak testing, coating, holiday checking etc. to complete the work in all aspect as per HPOIL Gas Laid Down procedure/SOPs & directions of E-I-C. Sleeves to be supplied by bidder. (Standard Type B Sleeve length of 80 Cm has been assumed). Leak clamp under owners scope.

The pipe sizes are of dia 12" , 8", 6" & 4".The rate also includes carrying out Non-destructive testing of Welds as per approved QAP & Specifications. MUT of faces of Pipes/ Fittings after cutting & grinding of bewelled edges prior to carry out the welding work. All the relevant applicable activities for the completion of Attend/Repair - Emergency Leak. Leak clamp to be installed till the time welding team mobilizes at site.

**6.1.13 R95 Painting:**

R-95 painting with one coat of 20 mils to be applied on steel pipe surface for corrosion protection.

**6.1.14 PCC:**

Supplying and laying plain cement concrete (including shuttering of required) in all types of concrete works including levelling courses below foundation, substructure, superstructure, chambers, cable trench, under floors and any other locations, at all levels as per specifications and directions of the Engineer-in-charge.

PCC 1:2:4

1 Cement: 2 Coarse sand: 4 stone aggregate 20mm nominal size.

(Rate to include cost of all labour, tools, tackles, equipment, hire charges, supply of all materials, shuttering, earthwork in excavation and backfilling using approved earth in all conditions etc. with all bye works and sundry works.)

**6.1.15 MDPE Laying**

1. Obtaining the approval for optimum route and permission for work from society management, RWA, individual residents and any other concerned authority, if required, for completion of the work.
2. Selection of route with the EIC/Consultant/TPIA and marking the same on walls/floors from PE network, transition fittings to stove/cooking oven/appliance, making openings and making provisions for fixing clamps. Making temporary but stable platforms/scaffolding/rope/ladder etc., required for installation of pipes/fittings at all heights/multi storied flats and locations.
3. Uncoiling/stringing the MDPE pipes of required sizes (20, 32, 63 & 125mm) pipes into trenches as per approved procedure.



4. Joining the pipe ends with fittings of valves by approved automated electro-fusion techniques only as per tender specification.
5. Supply and Installation of MDPE pipe fittings like Elbow, Tees, Reducers, Couplers, tapping saddles, Transition fittings, Valves and Sleeves etc. including construction of supports, Valves pits, Inspection chambers etc. as per specification, drawing & satisfaction of the Engineer In charge (EIC).
6. Laying pipelines by any methodology including open cut, trench less technology methods like Moling, HDD, etc.
7. Fabrication, supply and inspection of approved quality GI sleeve, HDPE duct and half concrete sleeves and other material, fittings to be supplied by the contractors as per the provisions of tender.
8. Back filling and compaction by jumping jack compactor wherever required, using approved 'good' soil or using excavated earth or borrow earth as per requirement and specifications and replacement of the tiles, slabs removed during the excavation. Cleaning all unserviceable materials, debris, excess earth trenches etc. to designated disposal area.
9. Carrying out pneumatic testing and purging as per specifications and approved procedures, providing all tools & tackles, instruments, manpower and other related accessories for carrying out the testing of pipes.
10. Restoration of existing ground features such as grass/turfing, paving, roads, drains, concrete, floral beds, fencing, tiles, marbles, flooring masonry etc. to original condition and to match with adjoining conditions, functionally and aesthetically up to the entire satisfaction of Owner / Owner's representative /any other third-party agency designated by owner and local authorities, failing which, it will be done at the risk and cost of the contractor. Obtaining No Objection Certificates for the restoration work done from the concerned authorities. No separate charges will be paid for restoration the laying rates are inclusive of restoring surface back to original state.
11. Handing over the completed works to owner along with detailed as built drawing showing pipeline route, fittings provided in the pipelines, for their operation purposes, 2 sets of colored drawings of A0 shall be provided, 1 at the time of commissioning and 1 at the time of closure of work order.
12. Free issue material is only MDPE pipe.

#### 6.1.16 GI Installation

1. Supply and Installation of powder coated GI pipes of ½" dia. Between transition fittings to customer's kitchen appliances including NPT threading of GI pipes, supply proper seal outs for threads to join fittings such as elbows, tees, connectors, meter regulators, meters, appliance & isolation valve etc., as per laid procedures and specification including clamping and sealing etc. The scratched powder coated GI pipe and fittings shall be painted after the testing of the GI installation.
2. Supply and Installation of GI fittings such as elbows, tees, connectors, etc., complete as per procedures and specifications including clamping and sealing etc.
3. Supply of clamps for fixing pipes, meters, valves wherever required. Providing consumable grout material, repair/restoration of walls/floors changes for the pipes including the materials required for conversions and tools and tackles etc. shall be complete as per specification.
4. Supply & Installation of Isolation Valve, Appliance Valve, Hose pipe etc., to complete the connection to the customer's appliance/stove.



5. Cleaning, flushing, pneumatic testing and commissioning to the GI pipe and fittings, meters, valves etc., as per specification and hand over the same to Owner/customer to the entire satisfaction of EIC.
6. Conversion of all types of LPG kitchen appliance to NG based appliance along with supply and installation of 1/2" Appliance Valve & Steel Reinforced Flexible Rubber Hose as per IS 9573.
7. Preparation and submission of Ready for Conversion (RFC) card for each house indicating the laid GI pipe including fittings, mentioned the reasons, if connection is not provided to the customers and deviation statements on completion/commissioning of work.
8. Approval of customer on RFC card & recording Joint Meter Reading (JMR) of customer.
13. Details for commercial connection.
14. To demonstrate to the Customer regarding use, safety and maintenance related aspects of NG based appliances and installations.
15. Dismantling of scaffolding/temporary structures and cleaning of site & restore the site as per its original condition.
16. Restoration of walls, flooring and other damages while executing the above ground installation.
17. All risers and lateral pipe shall be clamped to the building at intervals not exceeding 1 m in place of 1.5m. Two clamps to be installed at each bend fittings or Tee fittings. Clamps should be 150mm away from each joint.
18. Contractor shall conduct Cu joining Qualification Test for jointers Contractor has to supply different types/sizes of approved clamps.
19. Pneumatic testing of Riser at 2 bar (g) for 2 hours and Copper testing at 80 mbar for 5 minutes shall be done.
20. Only pretested riser shall be erected using pulley. Pretesting shall be done with compressed air @ 2 bar (g) for minimum duration of 30 minutes.
21. All the painting work must be done after completion of testing activity only
22. Testing of GI Installation \* Arrangement for pressurizing the installation should be shown with diagram. The testing of GI riser pipe up to regulator inlet point shall be done with isolation valve in open condition at TF side and closed condition at regulator side. PPT/Riser Testing and MMT/RFC must be certified by TPIA.
23. If tapping exceeds more than 15meters, will be chargeable from customer." It should be aware to customer at the time of either route survey or AFC drawing and shall be communicated to HOGPL/HPOIL GAS TPI.
24. All GI fittings must be Powder coated.
25. Inspection: It is the responsibility of contractor to get Job Card / RCF check drawing certified at site only by TPIA. Each meter geo tagged location and time stamped photo required at the time of commissioning
26. Certified copies of RFC card in form of editable Auto-Cad drawings, PDF and hard copy to be submitted along with geo co-ordinates of Riser to be submitted. JMR to mention geo co-ordinates stamped and time stamped meter reading photo WAH ropes must be certified by PETZL and all WAH accessories must be of PETZL make, only Printable material i.e. RFC book and sticker as per owner design for each connection must be in contractor's scope in place of Client's scope as per their format.
27. The contractor shall supply the Calibrated Go-No Go Gauge and BSPT/ NPT (as decided)



Gauges 1 set each of 1/2" and 1".

28. Any other activities not mentioned/covered explicitly above, but otherwise required for satisfactory completion/operation/ safety/ statutory/ maintenance of the works shall also be covered under the Scope of work and has to be completed by the Contractor within specified schedule at no extra cost to Owner.

**6.1.17 RCC Structur for Protection of Service Line:**

The scope includes construction, providing and laying cement concrete M-25 grade (Concrete shall be design mix/nominal mix) with 20mm down size graded crushed stone aggregates in non-suspended slabs/pavement slabs including pedestal/ramp etc., laying in alternate panels to required slopes, all necessary form work and finishing the surface rough/smooth as required in any position, shape, level thickness etc. as specified and directed by EIC. The rate includes grouting of pockets, supply of material, tools, shuttering, Reinforcement etc.

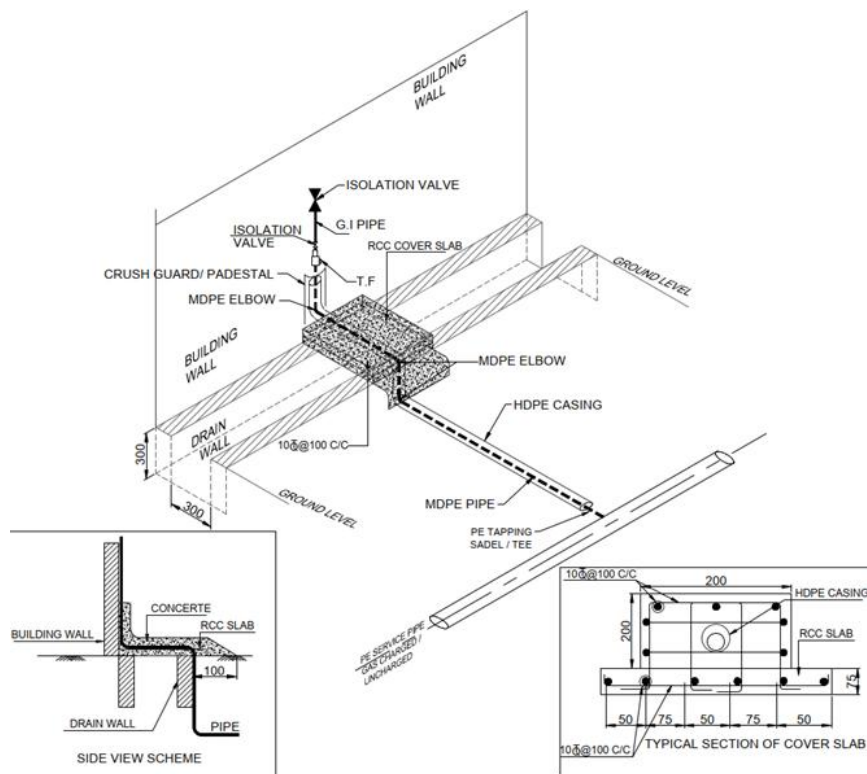

**DRAWING FOR RCC STRUCTURE FOR PROTECTION OF SERVICE LINE**



**Penalty matrix for Part-I activities**

Sr.No.	Particulars	UOM	Penalty in Rs.	Remarks
1	Non availability of Shift in-charge	Man day	2000	Approximate 2 times of daily wage
2	Non availability of PE-GI Technician / Plumber	Man- day	1200	Approximate 2 times of daily wage
3	Non availability of Helper	Man- day	1000	Approximate 2 times of daily wage
4	Non availability of Labor	Man- day	800	Approximate 2 times of daily wage
5	Response to Emergency i.e. Gas leakage complaint from above ground piping/ escape from underground PE pipe	Per Case	2500	To reach at the site within 45 mins from the receipt of the complaint
6	Non-Availability of tools and tackles, equipment at site	Per Tool per day	200	
7	Non-Availability of Consumables/Office set-up	Per Item Per Day	200	
8	Non-Availability of Emergency vehicle	Per Day	2500	
9	Non-Availability of Motorbike	Per Day	2000	
10	Nonperformance of preventive maintenance activities as per Maintenance Plan	Per Asset per month	500	Consider MDPE network as 1 Km = 1 Asset.
11	Indiscipline within the premises from the bidder's employees	Per employee per day	2500	
12	Noncompliance to complaints SLAs other than emergency complaints mentioned in above items	Per Complaint	500	
13	Non availability of Bidder's Scope materials as mentioned in minimum stock list	Per item per day	500	
14	Police verification of employees before deputation on job	Per person per day	500	
15	Non availability of office within 15 days of contract start date	Per day	2000	
16	Non-availability of office facility (Like Computer, Scanner, Telephone, Internet, and Printer etc.)	Per day per item	500	
17	Non submission of monthly MIS of previous month before 10 <sup>th</sup> day of next month	Per day	500	
18	Failure to maintain minimum tool tackles/equipment as per attached list	Per day per item	500	
19	Alcohol consumed person on duty penalty will attract and immediate termination by contractor.	Per day per manpower	3000	Also, Disciplinary action
20	Strike by contract employee due to mismanagement of contract by bidder	Per day	5000	Maximum 50000 Rs. Per contract year.
21.	Non maintain/ poor housekeeping and Toilet facility at Office	Per day	1000	



22	Non-Execution of assigned work by EIC any circumstances	Per day	1000	
23	Non-Compliances of Safety equipment e.g. Safety Harness belts, helmets, fluorescent jacket & Shoes, goggles etc.	Per day	1000	
24	In case of complete compliance of HSE norms	Per day	500	
26	In case it is noticed that any manpower deployed by contractor at O&M office found under fraudulent/unethical practices with the customer, if proved, a penalty shall be levied. It is discretion of Engineer-in-Charge to impose penalty.	Per instance	25000	
	In case of non-compliance of statutory provisions penalty will be imposed by the owner as detailed below:			
	Delay of more than 21 days from the date of work order in obtaining / submitting WC cover or taken	per week	5000	
	Delay of more than 21 days from the date of work order in obtaining / submitting the required insurance policies as specified in the tender document	per week	5000	
	The contractor must obtain labour license at the start of work at allotted site. Delay of more than 30 days from the date of work order	per week	5000	
	Refusal by any workman to carry-out any assigned job will make that workman liable for loss of wage for that particular day. In addition to that Rs500/-per person per day will be deducted by the contractor bills. In case of three repeated instances of refusal, misbehavior will make that worker to be replaced with another person.	Per person per instance	1000	
	In case of inordinate delay beyond 15th of the succeeding month in paying the wages to the workmen otherwise penalize. HOGPL will levy penalty of amount Rs 2000 per day in delayed	Per day	2000	



	period.			
	For not performing patrolling activity and non-submission of reports will attract penalty	Per day	1000	
	Non availability of Emergency Response Van (ERV) will attract a penalty	per day.	5,000/-	
	Non-availability of Driver on ERV will attract Penalty.	per shift	1000	
	Not maintaining the logbook & submission of records	per day per shift	200/-	
	Doing the gas geyser installations without HOGPL's authorization will attract penalty & immediate termination by contractor.	per Incident	1, 000/-	
	Non availability of GPS/GPS not working with Patrol man will attract penalty	Per day	500/-	
	Non submission of biometric attendance shall attract penalty	per month	3000/-	
	Non-Installation & connectivity of CCTV camera at both office shall levy penalty	Per month	2000/-	
	If Contractor, ask refund the some amount of salary from employees then Penalty will levy	per instance	Rs. 50,000/ -	



**SAFETY VIOLATION AND CONSEQUENCES**

Cat.	Classification	Examples/Cases	Penalty
A.	PPE related (only if not covered under point B)	Working without helmet, shoes, gloves etc.	Rs.1000/person/incident. Work should not be allowed till corrective action is undertaken
B.	SOP related	Unsafe walkway/ramp/ladder, failure to adhere to HSE guidelines/plans, careless attitude in material handling, machine being used with damaged machine guard, Unsafe working condition at height, unsafe electrical work - workout plug top/improper electrical joints/cables lying on ground, electrical equipment working without proper earthing, machine being used	Rs.2000/person/incident. Work should not be allowed till corrective action is undertaken
		Unsafe working condition at height more than 4 metres	Rs.5000/person/incident. Work should not be allowed till corrective action is
C.	Unauthorized Work (wherever applicable)	Working w/o permit or non-compliance with permit conditions like deep excavation, hot work etc. as applicable, lifting tools and tackles being used w/o third party inspection at	Rs.5000/violation. Work should not be allowed till corrective action is undertaken
		Driver w/o license, vehicle w/o permit/PUC/test certificates, using CNG in case of specified fuel, not having fire extinguisher etc.	Rs.500/violation
		Driver without ID Card, Driver not in shoes/uniform, Not having torch/umbrella/Stepney etc., late reporting of vehicle etc.	Rs.200/violation
		Improper handling of VTS Devices in car etc.	Rs.2000/violation or actual cost whichever is higher
Cat.	Classification	Examples/Cases	Penalty
D.	Other Unsafe Working Environment	Accident of any vehicle at plant site/premises/traveling for work related purpose - Overtuning, Colliding with an equipment or other vehicle, Fire in work area damaging work / properties, Improper Material Handling resulting in fall of heavy material from an height more than 1.5 Metres etc.	Rs.25,000/incident or damage to property whichever is higher
		Near Miss# which would have led to a fatality	Rs.5 Lakhs/incident

# Near miss is an unplanned event that did not result in injury, illness, or damage – but had the potential to do so. Only a fortunate break in the chain of events prevented an injury, fatality or damage; in other words, a miss that was nonetheless very near.



**Annexure-2**

<b>SLAs for PE-PNG O&amp;M Activities</b>		
<b>Sr. No.</b>	<b>Complaint Type</b>	<b>SLA</b>
1	FIRE/ GAS ESCAPE/GAS LEAKAGE/GAS SMELL (Response Time)	45 Min.
2	GAS SUPPLY STOPPAGE (Response Time)	45 Min.
3	METER REPLACEMENT	2 Days
4	METER NOT WORKING (Response Time)	2 Days
5	LOW OR HIGH GAS PRESSURE (Response Time)	60 Min.
6	PERMANENT DISCONNECTION	7 Days
7	TEMPORARY DISCONNECTION	2 Days
8	RECONNECTION TO BE DONE (AFTER TEMPORARY DISCONNECTION)	2 Days
9	CONNECTION VERIFICATION	7 Days
10	TEMPORARY DISCONNECTION – DUNNING	2 Days
11	REFITTING/FIXING RCC GUARD	2 Days
12	OTHERS (EXCLUDING ABOVE)	2 Days



**Annexure-3**

**LIST OF MINIMUM ITEMS FOR FIRST AID BOX UNDER BIDDER'S SCOPE**

<b>Sr.</b>	<b>Item Description</b>	<b>Qty.</b>
1	Small Dressing Gauze Swab for Finger Wound	8
2	Medium Dressing Gauze Swab for Hand or Feet Wound	8
3	Large Dressing Gauze Swab for Body Wound	8
4	Soframicin Cream Tube, 15 gm	1
5	Silver Sulphadizene Cream, 20 gm	1
6	Bottle of Antiseptic Solution 100 ml	1
7	Bottle of Mercurochrome Solution 100 ml	1
8	Absorbent Cotton Wool I.P 20 gm	4
9	Roll of Adhesive Plaster 2.5 cm X 1 Mt U.S.P.	1
10	Bandage Roll (5 cm X 2 Meter)	9
11	Eye Pad Each in Pkt (Sterile)	7
12	Strip of 10 Tablet Paracetamol I.P 0.5 gm	1
13	Potassium Permanganate I.P 20 gm	1
14	Boric Acid I.P 20 gm	1
15	Band Aid Strip	5
16	Dressing scissor 5" Stainless Steel	1
17	Tweezer Stainless Steel	1
18	Polythene Wash Bottle 250 CC For washing Eye	1
19	Tourniquet Cotton Belt & Buckle	1
20	Eye Wash Cup	1
21	Pair Wooden Stick	1
22	Safety Pins	12
23	Spray for Burn Injury 100ml	1
24	Spray for Muscle Sprain (Relispray) 100ml	1
25	Spray Antiseptic (100 ml)	1



**Annexure-4**

**List of Minimum mandatory safety equipment & PPEs under bidder's scope**

Sr. No.	Item Description	UOM	Quantity Per AEO
1.	Fire Extinguisher, ABC Type 5 & 10 Kg each, ISI mark	No.	2
2.	Safety Helmet per person (BS EN 397 or IS 2925)	No.	1
3.	LED torch – Flameproof	No.	2
4.	Dust Mask per person	No.	2
5.	Safety Shoes per person	Pair	1
6.	Electric shockproof Hand Gloves	Pair	2
7.	Safety Goggles per person	No.	1
8.	Ear Plug / Muff per person	No.	1
9.	Traffic Cone	No.	8
10.	Cordoning Tape	Roll	2
11.	Fluorescent Jacket per person	No.	1
12.	Rope with safety belts double lanyard	No.	1
13.	Megaphone / PA System	No.	1
14.	Gum Boots per person	Pair	1
15.	Rain Coat per person	No.	1
16.	Uniform – 2 pairs per person	Pair	2
17.	First-Aid Box (Items as per Annexure#3)	Box	1
18.	UHF mobile telecommunication set ( <b>To be provided by HPOIL GAS</b> )	No.	1
19.	Safety & Warning Signboards	No.	As per HPOIL GAS EIC instruction



**Annexure-5**

**LIST OF MINIMUM CRITICAL TOOLS & TACKLES UNDER BIDDER SCOPE FOR EACH  
AEO/Mini AE TEAM:**

**(Below List of tools & tackles shall be provided by contractor to both locations of Each GA )**

Sr. No.	Item Description	UOM	Require	Make
1	Drill Machine - 24"	NO.	1	Bosch
2	Drill Machine - 10"	NO.	1	Bosch
3	Drill Bit 5"	SET	2	Bosch
4	Wire Brush	NO.	2	Any standard make
5	Hack Saw with blade	NO.	5	Bipico
6	Small Hacksaw with blade	NO.	2	Bipico
7	Fire Blanket	NO.	1	Any standard make
8	Fire Retardant Suit	NO.	4	Any standard make
9	Flame Proof Torch - min. 25 lumens	NO.	1	Any standard make
10	Normal Torch. - min. 25 lumens	NO.	1	Any standard make
11	Screw Jack With Tommy Bar	NO.	1	Any standard make
12	Traffic cones / Plastic Barricades with fluorescent paint	NO.	10	Any standard make
13	Fusion Machine (Automatic Bar Code Reader Type)	NO.	1	GF/Kimplas
14	Generator - min. 5 kVA	NO.	1	Any standard make
15	De-watering /Mud Pump - 3.5 HP	NO.	1	Any standard make
16	Extension Board With cable of length 40 meters and RCCB / ELCB	NO.	1	Any standard make
17	Conversion Kit	Kit	1	Any standard make
18	PE Pipe Cutter 20-32 mm	SET	2	Any standard make
19	PE Pipe Cutter 63 -125 mm	SET	2	Any standard make
20	PE Pipe Scraper	NO.	3	Any standard make
21	Permanent Marker Pen	NO.	3	Any standard make
22	Re-rounding tools 63mm	NO.	1	Any standard make
23	Re-rounding tools 90mm	NO.	1	Any standard make
24	Re-rounding tools 125mm	NO.	1	Any standard make
25	Squeeze Tool 20 mm with earthing rod	NO.	2	Any standard make
26	Squeeze Tool 32 mm with earthing rod	NO.	2	Any standard make
27	Squeeze Tool 63mm to 90 mm with earthing rod	NO.	2	Any standard make
28	Squeeze Tool 125 mm with earthing rod	NO.	2	Any standard make
29	Hydraulic Squeeze Tool with earthing rod	SET	2	Any standard make
30	Alignment Clamp 125 mm	NO.	1	Any standard make
32	Alignment Clamp 63 mm	NO.	1	Any standard make
33	Alignment Clamp 32 mm	NO.	1	Any standard make
34	Alignment Clamp 20 mm	NO.	1	Any standard make



35	PE Saddle Clamp	NO.	1	Any standard make
36	Allen Key (Inch & Metric)	SET	2 each	Taparia
37	Iso-propyl Alcohol (500ml in each vehicle)	Bottle	1	Any standard make
38	Tissue Paper	Roll	5	Any standard make
39	Vice For Pipe along with BSPT Die	NO.	1	Jainson
40	Tool Box	SET	1	Taparia
41	Pipe Wrenches of all sizes (8" to 18")	NO.	1 each	Taparia
42	Side Wrench	NO.	1	Taparia
43	Screw Driver	SET	1	Taparia
44	Fix Spanner	SET	1	Taparia
45	Ring Spanner	SET	1	Taparia
46	Box Spanner	SET	1	Taparia
47	Hammer	NO.	2	Taparia
48	Plastic Hammer	NO.	2	Any standard make
49	Measure Tape - 10.0 mtr.	NO.	1	Any standard make
50	Fire Extinguisher 5 kg	NO.	2	Any standard make
51	Fire Extinguisher 10 kg	NO.	2	Any standard make
52	Emergency light (Flame proof Halogen light arrangement for work carried out during night)	NO.	1	Any standard make
53	Pressure Guage (0-10 bar & 0 - 4 bar,	NO.	2 each	Any standard make
54	Digital Pressure Gauge for LP network 0- 5000 mmwc	NO.	2	Any standard make
55	Digital Manometer 0-1999.9 mmwc	NO.	1	Any standard make
56	3 Mtrs height venting arrangement for venting of NG during Emergency with earthing facility	NO.	1	Any standard make
57	Spray Bottle	NO.	1	Any standard make
58	Trikam	NO.	3	Any standard make
59	Pawda	NO.	3	Any standard make
60	Tagara	NO.	3	Any standard make
61	Water Bucket	NO.	2	Any standard make
62	Sign Board	NO.	2	Any standard make
63	Torch/Battery	NO.	2	Any standard make
64	Chisel	NO.	2	Any standard make
65	File	SET	2	Any standard make
66	First Aid Box	NO.	1	As recommended by HPOIL GAS
67	2 1/2" Pipe Wrench	NO.	1	Any standard make
68	Valve Chamber Opener	NO.	2	Any standard make
69	PE Valve Chamber Key	NO.	3	Any standard make
70	Cordoning Tape	MTR	200	Any standard make
71	Non Sparking Tool Set	SET	1	Any standard make
72	Hard barricading	NO.	2	As per approved drawing
73	Site Umbrella (Summer)- Extra large	NO.	1	Any standard make
74	Garden Umbrella (Monsoon)- 49" or large	NO.	1	Any standard make
75	Teflon insulated crow bar	NO.	2	Any standard make



76	Aluminum ladder- rated load 150 kgs,3 mtr Length	NO.	1	Any standard make
77	Grass Hook (Hand Sickle)	NO.	1	Any standard make
78	Rubber mat	NO.	1	HPOIL GAS recommended
79	Tablet for O&M activity	NO.	1	HPOIL GAS recommended
80	Valve keys for valve operation - all sizes & types	NO.	2	Any standard make
81	Grease Gun	NO.	1	Any standard make
82	Gas Measuring Instrument	NO.	1	GMI
83	O2 Analyzer	NO.	1	Standard Make
84	Propane Torch Gun with Propane Cylinder	NO.	1	Standard Make
85	Copper cutter, Bender, Chamfer, Flux	NO.	1	Standard Make
86	Insulated tools	SET	2	Standard Make
87	Die electric shoes	SET	2	Standard Make
88	Rodometer	NO.	1	Standard Make
89	Electric Cable Locator	NO.	1	Standard Make
90	Insulated boring tools for 20 mm to 125 mm pipe sizes	Nos	1 Set	Standard Make
91	LEL Gas detector	Nos	1 set	Honeywell
92	Flame Proof Tool Kit	Nos	1 set	Standard Make



**Annexure-6**

**MINIMUM OFFICE SET UP REQUIREMENT**

**(Below List of tools & tackles shall be provided by contractor to each AEO)**

**(Applicable for offices rented by the bidder)**

<b>Sr. No</b>	<b>Details</b>	<b>Minimum Quantity</b>	<b>Minimum Specifications</b>
1	Computer/Laptop	02 no.	Intel® Core™ i3 Series Processor with at least 1.2 GHZ, Minimum of 4 GB memory, 500 GB HDD, Monitor and Keyboard
2	A4 B/W or Color Printer	1 no.	
3	Scanner	1 no.	
4	Table & Chairs	Adequate Nos.	
5	Cup Board / Almirah	1 no.	For storing high value material & tools & tackles
6	Racks for Storeroom	4 nos.	For stacking of Materials
7	Air Conditioner & Ceiling Fans	In all rooms	Of adequate capacity
7	Mobile phone for Emergency Toll Free Number	1 nos.	Operation System- Android 14; RAM - minimum 4 GB; ROM - minimum 64 GB; Camera- minimum 12 Megapixels; Screen Size - 5.5 Inch; Battery - minimum 5000 mAh; Touchscreen Display
8	White Board with Duster & Marker (2 Ft X 4 Ft), Notice Board (2 Ft X 4 Ft)	1 of Each	
9	Stationery Items incl. A4 size Papers, Box & Flat files, Registers etc.	Adequate Nos.	
10	Facilities like Tea/Coffee, Drinking water, Toilet etc.		For All Bidder's Employees



**Annexure-7**

Sr. No	Item with Specification	UOM	Minimum Quantity		To be supplied by
			Emergency Van per Vehicle	Store	
1	Warning Mat (Yellow)	M	200	400	Bidder
2	Meter Adaptor for G 1.6 Domestic Gas Meters	SET	5	25	Bidder
3	Bushing of B-6 Riser Regulator (1/2"x3/4"&1/2"x3/4")	SET	2	10	Bidder
4	Bushing of B-10 Service Regulator (1"x 3/4" & 1"x 1")	SET	2	10	Bidder
5	Bushing of B-25 Service Regulator (1"x 3/4" & 1"x 1")	SET	2	10	Bidder
6	Bushing of B-50 Service Regulator(1"x3/4"&1"x1.1/4")	SET	2	10	Bidder
7	Bushing of MS6/MS10/FE-25 Service Regulator (1"x1"&1"x1")	SET	2	10	Bidder
8	Bushing of FE-50 Service Regulator (1"x1" & 1"x1.1/4")	SET	2	10	Bidder
9	G.I. Coupling 15 mm (Socket)	EA	5	20	Bidder
10	G.I. Elbow 15mm	EA	5	50	Bidder
11	G.I. Hex Nipple 15mm	EA	5	20	Bidder
12	G.I. Plug 15mm	EA	5	50	Bidder
13	G.I. Reducer 25 x 15mm	EA	5	25	Bidder
14	G.I. Tee 15mm	EA	5	30	Bidder
15	G.I. Union 15mm	EA	5	10	Bidder
16	G.I. Bushing 1/2 " x 3/4"	EA	5	25	Bidder
17	1/2" x 2" Long G.I. Pipe Nipple Both side thread.	EA	5	25	Bidder
18	1/2" x 3" Long G.I. Pipe Nipple Both side thread.	EA	5	25	Bidder
19	1/2" x 4" Long G.I. Pipe Nipple Both side thread.	EA	5	25	Bidder
20	1/2" x 6" Long G.I. Pipe Nipple Both side thread.	EA	5	25	Bidder
21	G.I. Plug 25mm	EA	5	25	Bidder
22	G.I. Coupling 25mm (Socket)	EA	5	10	Bidder
23	G.I. Elbow 25mm	EA	5	10	Bidder
24	G.I. Hex Nipple 25mm	EA	5	10	Bidder
25	G.I. Tee 25mm	EA	5	10	Bidder
26	G.I. Union 25mm	EA	5	10	Bidder
27	1" x 3" Long G.I. Pipe Nipple Both side threaded	EA	2	10	Bidder
28	1" x 4" Long G.I. Pipe Nipple Both side threaded	EA	2	10	Bidder
29	1" x 6" Long G.I. Pipe Nipple Both side threaded	EA	2	10	Bidder
30	"Suraksha" Hose	EA	5	50	Bidder
31	Hose clamps	EA	10	100	Bidder
32	R.C.C. Guard	EA	2	25	Bidder
33	Brass Bush 1/2" x 1/4" (G.I. to Gas Tap)	SET	5	25	Bidder
34	Brass Disconnect Union 1/2" x 12mm (G.I. to Copper)	EA	2	10	Bidder
35	Brass Bush 12mm x 1/4" (Copper Pipe to Gas Tap )	EA	2	10	Bidder
36	PVC Clip For 12mm Copper Pipe	EA	10	50	Bidder
37	Pressure Gauge - Range: 0 - 250 mbar (	EA	2	2	Bidder



	Waaree )				
38	Pressure Gauge - Range: 0 - 6 bar ( Waaree )	EA	2	2	Bidder
39	Service Regulator Boxes with canopy, lock & key	NO	0	5	Bidder
40	PE Coupler 20mm	EA	10	50	Bidder
41	PE Coupler 32mm	EA	10	50	Bidder
42	PE Coupler 63mm	EA	4	20	Bidder
43	PE Coupler 125mm	EA	4	20	Bidder
44	PE End Cap 20mm	EA	2	10	Bidder
45	PE End Cap 32mm	EA	2	10	Bidder
46	PE End Cap 63mm	EA	2	10	Bidder
47	PE End Cap 125mm	EA	2	10	Bidder
48	PE Eq. Tee 20mm	EA	1	5	Bidder
49	PE Eq. Tee 32mm	EA	1	5	Bidder
50	PE Eq. Tee 63mm	EA	1	5	Bidder
51	PE Eq. Tee 125mm	EA	1	5	Bidder
52	PE Elbow 32mm X 90 Deg.	EA	4	20	Bidder
53	PE Elbow 63mm X 90 Deg.	EA	4	20	Bidder
54	PE Elbow 125mm X 90 Deg.	EA	4	20	Bidder
55	PE Reducer 32mm X 20mm	EA	2	10	Bidder
56	PE Reducer 63mm X 32mm	EA	2	10	Bidder
57	PE Reducer 125mm X 90mm	EA	2	10	Bidder
58	PE Top Tee 32mm X 20mm (Saddle)	EA	2	10	Bidder
59	PE Top Tee 63mm X 32mm (Saddle)	EA	1	5	Bidder
60	PE Top Tee 125mm X 32mm (Saddle)	EA	1	5	Bidder
61	EF Transition Fittings 20 X 1/2"	EA	5	25	Bidder
62	EF Transition Fittings 32 X 1"/63 X2"	EA	2	10	Bidder
63	Teflon tape	EA	10	50	Bidder
64	Domestic meter "O" Ring	EA	20	100	Bidder
65	Gas tap rubber cap	EA	5	25	Bidder
66	NIPPLE HEX BLIND,2IN,TH BSPT,MS	EA	5	25	Bidder
67	Brass Ball Valve 15 mm (1/2" )	EA	5	30	Bidder
68	Brass Ball Valve 25 mm ( 1" )	EA	2	10	Bidder
69	Appliance Valve 1/4" X 6.4mm	EA	2	10	Bidder
70	Appliance Valve 1/2" (Direct)	EA	10	50	Bidder
71	125 mm Ball valve	EA	0	2	Bidder
72	63 mm Ball valve	EA	0	2	Bidder
73	G.I. Pipe 15 mm	M	3	100	Bidder
74	G.I. Pipe 25mm	M	2	10	Bidder

Sr. No	Item with Specification	UOM	Minimum Quantity		To be supplied by
			Emergency Van	Store	
1	Dom. Gas Meter G-1.6	EA	5	25	Owner
2	Domestic Meter Regulator	EA	10	50	Owner
3	Service Regulator B-6 (110 mbar)	EA	1	5	Owner
4	Service Regulator B-6 (24 mbar)	EA	1	5	Owner
5	Service Regulator B-10 (110 mbar)	EA	1	5	Owner
6	Service Regulator B-10 (24 mbar)	EA	1	5	Owner
7	Service Regulator B-25 (110 mbar)	EA	2	10	Owner
8	Service Regulator B-50 (85 mbar)	EA	2	10	Owner
9	MDPE PE 100 PIPE 63 mm Dia SDR 11	M	4	20	Owner
10	MDPE PE 100 PIPE 32 mm Dia SDR 11	M	10	50	Owner
11	MDPE PE100 PIPE 20 mm Dia SDR 9	M	10	50	Owner
12	MDPE PE 100 PIPE 125 mm Dia SDR 17.6	M	4	20	Owner
13	High Pressure Leak clamp for Carbon Steel	EA	-	1	Owner



	Pipeline, 12 inch (300 class)				
14	High Pressure Leak clamp for Carbon Steel Pipeline, 12 inch (300 class)	EA	-	1	Owner
15	High Pressure Leak clamp for Carbon Steel Pipeline, 12 inch (300 class)	EA	-	1	Owner
16	High Pressure Leak clamp for Carbon Steel Pipeline, 12 inch (300 class)	EA	-	1	Owner

**Note:**

For SOR line items 12 to 85 the item rates are inclusive of bidder scope materials (otherwise specified in SOR description) the bidder specified items are to be supplied by bidder and cannot be claimed through supply items SOR.

Whereas for leak repair/shifting of MPDE (less than 3 mtrs) & leakage rectification of GI section through AEO Team, HPOIL Gas will provide free issue materials consisting of all size of PE pipes, GI Pipe, Isolation valves, Appliance valves, Hose Pipe, PE ball valves, domestic gas meters, meter regulator, service regulators whereas rest of the materials such as GI/PE fittings, rubber hose pipe, warning tape, clamps or any other fittings not mentioned but required to perform task can be claimed through supply items SOR. All materials which are to be supplied by bidder shall be as per technical specifications of HPOIL GAS and before using at site, shall be inspected/approved by HPOIL GAS team.



**Annexure-8**

**MINIMUM PREVENTIVE MAINTENANCE SCHEDULE COVERED UNDER Part-I**

Sr. No.	Category/Asset/Equipment/Activity	Frequency
1.	Service Regulators	Monthly
2.	Riser Regulators	Quarterly
3.	PE Patrolling	Daily
4.	Steel Network Patrolling	Daily
5.	Leak Detection Walk in Survey of PE network	Half Yearly
6.	PE Ball Valve Inspection	Monthly
7.	PE Ball Valve Chamber Cleaning/Maintenance	Monthly
8.	Lock Pressure Test of PE Network	Quarterly
9.	DRS/MRS Cleaning & Maintenance	Bi-Monthly
10.	PE route marker Counting	Bi-Monthly
11.	Tool & Tackles in Emergency vehicle	Weekly
12.	Emergency Vehicle & Two-Wheelers	As per OEM schedule
13.	Any other preventive predictive , schedule maintenance	As per EIC direction

## 7 GUIDELINES FOR CONTRACTOR SCOPE MATERIALS

### 7.1 MDPE Fittings:

**Reference standard:** EN 1555-3- Plastic piping systems for the supply of gaseous fuels- Polyethylene (PE) part-3: fittings

**Approved Vendor list:** (List will be updated and circulated periodically subject to input from GA and interest of new vendors subject to compliance to approved technical credentials.)

MDPE Fittings and Crimping Fittings:

- Georg Fisher piping system Pvt Ltd
- Kimplas Piping Systems LTD. 301, Abhimaan - II, 3rd Floor, Teen Hath Naka, Naupada Mr. Prakash Amin/Mr. Sagar Shinde 25489448, 32400755
- Aliaxis (Annoge) Utilities and Industry Pvt Ltd 704, Shivalik Abaise, Prahaladnagar Road, Satellite 079 4037 0333, 079 40371333
- Green Globe solution: 19, Anupam Ind. Estate No.2, Ralli Wolf, off. L.B.S. Marg, Mulund (W) , Mr Paresh Veera- 022-25654408--crimping
- Max engineering: 11, Damji Shamji Industrial Estate, LBS Marg, Vikhroli (W), Mr Nimesh Shah, 25783094/25783108-crimping
- Chandan enterprises: No.9, Sipoy Chawl, Mathurdas Mill Compound, SenapatiBapat Marg, Lower Parel, Mr. Jagdish Chandan 24921551-crimping

### 7.2 Warning tape:

**Technical details: Detailed technical and QAP attached separately-Annexure II**

**Approved Vendor list:** (List will be updated and circulated periodically subject to input from GA and interest of new vendors subject to compliance to approved technical credentials.)

Warning Tape:

- Sparco Multiplast Pvt. Ltd., Ahmedabad (Warmat)
- Singhal Industries, Ahmedabad
- Polycan

### 7.3 GI/Wrought Fittings: Reference standard: IS 1239 (part-II) -1990/ IS 1879- 2001

**Technical details: Detailed technical and QAP attached separately-Annexure II**

**Approved Vendor list:** (List will be updated and circulated periodically subject to input from GA and interest of new vendors subject to compliance to approved technical credentials.)

GI fittings:

- M/s Jainsons Industries, Jalandhar, Basti Bawa Khel, Kapurthala Road, Jalandhar 144 021 (Punjab.) INDIA, 0181509344, 9814665033, 9855588333
- M/s Chokhawala Distributors, Surat, 4/2509, Salabatpura Nani Begum Wadi, Near Mukti Dham Mandir, Surat, Gujarat, 898000150, 98795 75559
- M/s Mehta Brothers, Mumbai. 54, Nagdevi Cross Lane, Mumbai - 400003, India, 9820870254, 93231 21661
- MODERN STORES & ENGINEERING CONCERN, HOWRA, WEST BANGAL, 033-6679284

### 7.4 Brass fittings (Meter inlet and outlet adaptor, connector)

**Reference standard:** IS 319: 2007, Grade I Free cutting Brass Bars, Rods & Sections -Specification  
**Technical details:** Detailed Technical and QAP attached separately-Annexure II Drawing attached separately

**Approved Vendor list:** (List will be updated and circulated periodically subject to input from GA and interest of new vendors subject to compliance to approved technical credentials.)

Brass fittings:

- Green Globe solution: 19, Anupam Ind. Estate No.2, Ralli Wolf, Off. L.B.S. Marg, Mulund (W) , Mr Paresh Veera- 022-25654408
- KABSONS GAS EQUIPMENT PVT. LTD. 7-1-48/2/2, Raja Sham Karan Road.,Ameerpet 040-2373 0487
- UMESH ENTERPRISES, 02, Vakharia Indl Estate, Ram Mandir Road, Goregaon(W), 9819872626
- M/s Jainsons Industries, Jalandhar, Basti Bawa Khel, Kapurthala Road, Jalandhar 144 021 (Punjab.) INDIA, 0181509344,9814665033,9855588333
- M/s Chokhawala Distributors, Surat, 4/2509, Salabatpura Nani Begum Wadi, Near Mukti Dham Mandir, Surat, Gujarat, 898000150, 98795 75559

#### **7.5 Riser guard, Markers, Precast RCC chamber for PE valve installation, GI pipe Clamps with screw, PTFE tape:**

Detailed drawings attached (except PTFE) and Suitable size of Meter bracket as applicable: Suggested Local vendors by Bidder and accepted by GA in-charge will be added in approved list.

**General note:** Bidder can suggest new vendor for supply of above-mentioned all materials to GA in-charge and based on credential of vendor, Vendor name will be included in approved list. Approved list will be updated on periodic basis. Updated list will be shared to all bidders and shall be acceptable to all bidders

### **8 TECHNICAL SPECIFICATION**

#### **8.1 WARNING TAPE**

This specification is applicable for warning tape installation on pipeline. This document covers the technical specifications for the procurement of Warning Tape. Warning Tape shall be laid on the ground above the gas pipeline (main line) in order to indicate their presence.

#### REFERENCE CODE

EN 12613 – Plastics warning devices for underground cables and pipelines with visual characteristics

#### FEATURES

##### **Material**

Warning Tape, Type 1 as per EN 12613 shall be used.

The material of Warning Tape shall be Virgin High-Density Polyethylene (PE) material and Non bio degradable type. It shall have nontoxic and Anti-rodent properties with sticker/ stamp. The material shall have the density between 0.940 to 0.958 Kg / M<sup>3</sup> at 270 deg. Celsius as per IS 7328. The tape shall be uniform in colour, texture and finish and shall be free from holes and foreign materials. Rodent repellent chemicals to be added to the plastic master batch for protection against rodents.

The material and colour, if used, for printing shall have no detrimental effects on the environment.

##### Mechanical properties

Mechanical properties of the Warning Tape (Type I) shall be in accordance with the code EN 12613. The minimum tensile withstand load in longitudinal direction shall not be less than 200 N. The test piece shall not exhibit a reduction of more than 20% of its width after removal of the specified load.

##### Colour

The Warning Tape shall be of Yellow Colour with letters printed in as per given layout in Annexure-A non-detectable type with high abrasion resistance Dimensions.

Warning Tape shall have following dimensions:

Width 300 ± 5 mm

Thickness 0.3 mm (Minimum) Negative tolerance on the thickness is not allowed. Marking

The warning tape shall be marked at intervals not exceeding 1 meter. Marking on the tape shall be

approved by owner. The marking shall be legible and durable. The warning tape must be printed with "Caution: High Pressure Gas Pipeline Below" in both English and Hindi language, Chainage marking along with Owner's logo and Owner's 24 Hours Emergency Number -----, at a frequency of every meter. In addition, name or trademark of the manufacturer, year of manufacture and reference of code of manufacture of warning tape shall be included in the marking.

Vendor shall submit proposed Artwork to be marked on the Warning Tape for approval from Owner.

#### Tests

All the tests and test procedures for Warning Tapes shall be as per EN 12613 or as per required National/ International standards mentioned in EN 12613. In addition, all requirements pertaining to statutory requirements, if any, as specified from time to time shall be complied.

The required tests are briefed as below:

#### Colouring

Three separate tests shall be carried out in accordance with:

As per normative annexure B of EN 12613, using 20% ammonium sulphide. As per EN ISO 175, using 10% nitric acid & 20% sodium carbonate solution. The tests shall be repeated for each colour (if any).

There shall be no discolouration or change of the initial colour of the warning tape after the tests.

#### Tensile Withstand Strength

The test sample shall be selected as mentioned in EN 12613. The test samples shall be preconditioned for not less than 12 h at  $23 \pm 2$  °C. Static loads shall be carried out to the samples over a period of 10 s.

After the test, the test piece shall withstand without starting to separate at weak points (if any) for not less than 5 minutes. Also, it should not exhibit a reduction of more than 20% of its width after removal of specified load.

The minimum tensile withstand load for the warning tape in the longitudinal direction shall be not less than 200 N.

#### **Visual Warning Characteristics:**

The test shall be carried out in accordance with normative Annexure A of EN 12613.

#### Permanence of Printing

The test shall be performed as per CL. 9.3 of IEC 60898:1995.

The test is made by rubbing the marking by hand for 15 sec with a piece of cotton soaked with water and again for 15 sec with a piece of cotton soaked with aliphatic solvent hexane with a content of aromatics of max. 0.1% by volume, a kauributanol value of 29, an initial boiling point value of approx. 65°C, a dry point of approx. 69°C and a density of approx. 0.68 gm/cm<sup>3</sup>.

After the test, the marking shall be easily legible.

#### Test of laying Characteristics

The test is for the assessment of transverse rigidity of the warning tapes. The test shall be performed as per EN 12613.

#### Warning Tape Virginity Test:

Differential Scanning Calorimeter (DSC) Scan test along with the temperature of melting ( $T_m$ ) shall be performed for the Warning Tape and its raw polymer i.e. virgin high-density polyethylene (HDPE).

The Differential Scanning Calorimeter (DSC) Scan curve of the Warning Tape obtained from its DSC Scan test along with its Temperature of Melting ( $T_m$ ) shall then be compared with the DSC Scan curve and the Temperature of Melting ( $T_m$ ) of its raw polymer (i.e. virgin HDPE).

To ensure the virginity of the Warning Tape, the DSC Scan curve and  $T_m$  of the Warning Tape (finished product manufactured from the raw polymer) shall match on overlapping with its corresponding raw polymer's DSC Scan curve and  $T_m$ .

## Packing

The warning tape shall be delivered in rolls of minimum 50 meters. Packing size to be mentioned to ensure uniformity in delivery conditions of the materials being procured. Bidder shall submit the packing details during offer and also compiled with at the time of delivery. Packaging of the Warning Tapes shall be such that there won't be any deterioration due to Ultraviolet (UV) effect during transportation and storage of the Warning Tapes prior to use.

## QUALITY ASSURANCE (QA)

Manufacturer shall prepare detailed Inspection Test Procedure (ITP) and submit for approval from EPC contractor / Owner's representative.

## RECOMMENDED MANUFACTURER FOR RAW MATERIAL

INEOS, BOREALIS, TOTALPETROCHEMICALS, DOW, BASSELL, RELIANCE, GAIL, HALDIA

However, any other reputed national or international Manufacturer may also be considered for supply of Raw material with approval of PMC/ Owner's representative.

## ANNEXURE-A



Helpline no to be confirm with GA in-charge before printing

## QAP:

S. No	DESCRIPTION	Reference Document PTS	INSPECTION METHODOLOGY	INSPECTION	
				MFG. / CONTRACT OR	TPIA
1	Raw Material Inspection	Polyvinyl Chloride or Polyethylene	Material test certificate	H/P	Rw
2	Ultimate Tensile Strength at Break	Minimum 12 N / mm <sup>2</sup>	Material test certificate	H/P	Rw
3	Colour	Bright Yellow Colour	Physically Visual	P	W
4	Width	300 mm $\pm$ 5 mm	Scale	P	Rv
5	Thickness	Min. 300 Micron in thick	Vernier / Micrometer	P	Rv
6	Marking / Art Work	Marking on the Tap shall be approved by owner at every 1 Meter of Warning Tap	<b>Sample to be prepared for approval.</b>	P	Rv
7	Colour Bleeding	technical	Document	P	Rw

## 8.2 GI FITTINGS

The material used for the manufacturing of GI fittings shall conform to IS1879-2010 or IS 14329 –1995 with latest amendments.

### PRESSURE TEST

Vendor shall carry out pneumatic pressure test as per Clause 11 of IS:1879 – 2010 with latest amendments on each & every fitting. Vendor to submit the Internal Quality control certificate for the same. Witness of pneumatic testing by owner/TPI shall be as per the sampling procedure specified in IS:1879-2010 with latest amendments.

### COMPRESSION TEST

This test shall be conducted to judge the malleability of the pipe fittings & shall be carried out as per Clause 12 of IS:1879 – 2010 with latest amendments.

### SAMPLING

Owner Representative of Third-Party Inspection Agency appointed by Owner shall witness the tests as per Appendix-B of IS 1879 – 2010 with latest amendments. However, vendor to perform 100% inspection of visual, dimensional & pressure test. Vendor shall furnish Internal test certificates at the time of final inspection to the Owner.

### DIMENSIONS AND DIMENSIONAL TOLERANCES

1. Dimensions of various types of fittings shall be as specified in sections 2 to 10 of IS 1879 – 2010 with latest amendments, as applicable.
2. Wall thickness of fittings and tolerances on them shall be as given in Table 2 & 3 of IS 1879 – 2010 with latest amendments.
3. In case of reducing fittings, the dimensions at each outlet shall be those appropriate to the nominal size of the outlet.
4. All GI fittings shall be of reinforced type. Reinforcement shall be provided as per IS: 1879.

### WEIGHT

Weights of various types of fittings shall be as specified in sections 2 to 10 of IS 1879 – 2010 with latest amendments, as applicable.

### THREADS

1. Threads shall be NPT type and conforming to ASME B1.20.1.
2. Outlets of fittings shall be threaded to dimensions & the tolerances as specified in ASME B1.20.1.
3. All internal & external threads shall be tapered.
4. For checking conformity of threads gauging practice in accordance with ASME B1.20.1 shall be followed.
5. Chamfering: The outlet of fittings shall have chamfer.

### FREEDOM FROM DEFECTS

On visual examination, the outside & inside surfaces of fittings shall be smooth & free from any defects such as cracks, injurious flaws, fine sand depth etc.

### GALVANIZING

- Fittings shall be galvanized to meet the requirement of IS: 4759 – 1996 with latest amendments.
- Zinc conforming to any grade specified in IS: 13229-1991 with latest amendments shall be used for the purpose of galvanizing.
- Galvanizing bath: The molten metal in the galvanizing bath shall contain not less than 98.5% by mass of zinc.
- Coating requirements: Mass of coating shall be more than 400 g/m<sup>2</sup>. (IS 6745)
- Freedom from defect: The zinc coating shall be uniformly adhered, reasonably smooth & free from such imperfections as flux, ash bare patches, black spots, pimples, lumpiness runs, rust stains, bulky white deposits & blisters.

Sampling plan and testing for Galvanization:

- All materials of the same type in coating bath having uniform coating characteristics shall be grouped together to continue a lot. Each lot shall be tested separately for the various requirements of the specification. The number of units to be selected from each lot for this purpose shall be given in Table 2 of IS 4759 – latest edition.
- The sample selected according to Column 1 & 2 of Table 2, IS: 4759 –latest edition shall be tested for visual requirements as per Clause 6.2 of IS:4759 – latest edition.
- The sample found conforming to above requirements shall then be tested for mass of zinc coating in accordance with Clause 9.2 of IS: 4759 –latest edition.
- Criteria for conformity: As per Clause 8.3 of IS: 4759-latest edition.
- Test procedure shall be as per Clause 9 of IS: 4759-latest edition.

#### POWDER COATING.

Pure Polyester Powder coating has to be done on Galvanized fittings as per prevalent technical specifications for Powder Coating. The powder coating shall meet the requirements of BS 6497 &EN 12206-1.

#### SPECIFICATION FOR POWDER.

Powder Type	Pure Polyester (PP)
Color	Golden Yellow color (light), to be approved by Owner
Gloss range @ 60° (Gloss head)	80 - 95%
Specific gravity	1.2 to 1.8 (Depending upon the color & Finish)

The powder should be stored in a cool and dry place at a temperature not exceeding 25 deg C and at a relative humidity not more than 65%. Direct exposure of the powder to heat or sunlight must be avoided. The storage life of powders under the above conditions will not be less than 6 months.

The vendor shall not use powder which has exceeded the storage life recommended by the manufacturer of the powder.

#### SPECIFICATION FOR POWDER COATING.

Thickness of Powder Coating*	ERW GI Pipes (Heavy Class): Minimum 60 Microns
Type of finishing	Glossy finish
Method of application of powder	Electrostatic Spraying. (40 – 90 kV, Manual / Automatic)
Baking Schedule	180 °C to 200 °C for 10 minutes (Metal Temperature)

\* The thickness mentioned above is of powder coating only and does not include the thickness of the galvanization of the pipe / fitting.

#### MARKING and PACKAGING

- Each fitting shall be embossed with manufacturer's name or trademark and Designation of fittings the size (if space permits) and lot number. Each fitting conforming to this standard shall also be marked with BIS standard mark.

- Suitable packing to ensure quality of material.

#### INSPECTION / DOCUMENTS

1. Inspection shall be carried out as per Owner Technical Specification/ referred codes. Owner Representative or Third Party Inspection Agency appointed by Owner shall carry out inspection during manufacturing / final inspection.

2. Vendor shall furnish all the material test certificates, proof of approval / licence from specified authority

as per specified standard, if relevant, internal test /Inspection reports as per Technical Specification & specified code for 100% material, at the time of final inspection of each supply lot of material.

**Tentative QAP:**

SN	Characteristics	Reference documents	Acceptance norms	Scope-Vendor	TPI
1	Chemical composition, Compression test, Pressure test,	IS 1879	Material certificates	Performance	Rw
2	Physical , wall thickness (IS 1879) and visual verification	Dimensions, wall thickness, Threads, cracks, surface smoothness, chamber burr, alignment, chamfering	As per Technical details	Performance	Rv
3	Galvanising, Powder coating	Chemical analysis, Thickness	As per Technical details	Performance	Rw
	<b>Rw-Documents review</b>	<b>Rv:Random verification</b>			

**8.3 Wrought Steel Fittings**

**DIMENSIONS & DIMENSIONAL TOLERANCES.:** Dimensions of various types of fittings, and wall thickness on fittings and tolerances on them shall be as specified in IS 1239 Part 2: 2011.

The material used for the manufacturing of Wrought Steel Fittings shall conform to IS 1387: 1993 generally, and IS 1239 Part 2: 2011.

**THREADS.**

Threads shall be NPT type and conforming to ASME B1.20.1 . Outlets of fittings shall be threaded to dimensions & the tolerances as specified in ASME B1.20.1. All internal & external threads shall be tapered. After threading, the pipe body may be hot dip galvanized as per normal practice followed by cold galvanizing (spraying) of the threaded portions. The threaded portions shall be protected using end caps, etc. For checking conformity of threads gauging practice in accordance with ASME B1.20.1 shall be followed.

**FREEDOM FROM DEFECTS:** On visual examination the outside & inside surfaces of fittings shall be smooth & free from defects such as cracks, injurious flows, fine sand depth, etc. Other workmanship shall be as per IS 1239 Part 2: 2011.

**GALVANIZING:** Fittings shall be galvanized to meet the requirements of IS 4759: 1996.

- Zinc conforming to any grade specified in IS 209: 1992 or IS 13229: 1991 shall be used for the purpose of galvanizing.
- **Galvanized Bath:** The molten metal in the galvanizing bath shall contain not less than 98.5% by mass of zinc.
- **Coating requirements:** Mass of coating shall be 610 gms/m<sup>2</sup>. In case of pipe nipples (manufactured in accordance with the requirements of IS 1239 Part 2: 2011), the mass of coating of 400 gms/m<sup>2</sup> shall also be acceptable.
- **Freedom from defects:** The zinc coating shall be uniformly adhered, reasonably smooth & free from such imperfections as flux, ash bare patches, black spots, pimples, lumpiness, runs, rust strains, bulky white deposits & blisters; otherwise the Fittings shall be liable for rejection.

**Sampling Plan for Galvanizing**

- All materials of the same type in a coating bath having uniform coating characteristics shall be grouped together to constitute a lot. Each lot shall be tested separately for the various requirements of the specification. The number of units to be selected from each lot for this purpose shall be as given in Table 2 of IS 4759: 1996.
- The sample selected according to Column 1 & 2 of Table 2, IS 4759: 1996 shall be tested for visual requirements as per para 8 of IS 4759: 1996. Vendor shall have appropriate correspondence between galvanizing lot number and pipe manufacturing lot number for identification / traceability.
- The sample found conforming to above requirements shall then be tested for mass of zinc coating in accordance with Clause 9.2 of IS 4759: 1996.
- Criteria for conformity: As per Clause 8.3 of IS 4759: 1996.
- Test procedure shall be as per Clause 9 of IS 4759: 1996. All galvanizing test results shall be included in the Manufacturer's Test Certificate.

**PRESSURE TEST.**

Pneumatic pressure test shall be carried out on each & every fittings as per procedure given in IS 1239 Part 2: 2011.

**SAMPLING.**

If required, Owner representative or Third-party inspection agency appointed by Owner / owner appointed agency shall witness the tests as per IS 4711: 2008. However, vendor to perform 100% inspection of visual, dimensional & pressure test. Vendor shall furnish Internal test certificates at the time of final inspection by Owner/owner appointed agency.

**MARKING.**

Each fitting shall be embossed with manufacturers name or trademark & the size designation. Each packing containing fittings shall carry the following stamped or written by indelible ink.

- Manufacturers name or trademark.
- Designation of fitting.
- Lot number.
- Date of manufacture (at least the year), may be in code (For example, 2009 may be marked as "09").

Each fitting conforming to this standard shall also be marked with **BIS** standard mark.

**INSPECTION / DOCUMENTS.**

1. Inspection shall be carried out as per Owner Technical Specification/ referred codes. Owner Representative or Third-Party Inspection Agency appointed by Owner shall carry out inspection during manufacturing / final inspection.
2. Vendor shall furnish all the material test certificates, proof of approval / licence from specified authority as per specified standard, if relevant, internal test / Inspection reports as per Technical Specification & specified code for 100% material, at the time of final inspection of each supply lot of material

**QUALITY ASSURANCE PLAN (QAP) FOR WROUGHT STEEL FITTINGS**

SN	Characteristics	Reference documents	Acceptance norms	Scope-Vendor	TPI
	Raw Material:				
1	Chemical composition	IS 1239 part 2, PTS	Material test certificates	Perform	Rw
	Physical Properties	IS 1239, part 2 PTS	Material test certificates	Perform	Rw

2	Physical , wall thickness and visual verification, Dimensions, wall thickness, Threads, cracks, surface smoothness, chamber burr, alignment, chamfering	IS 1239 aprt 2, PTS	As per Technical details	Perform	Rw
3	Galvanising	Chemical analysis IS 4759:1996	As per Technical details	Perform	Rw
4	Marking	IS: 1239(Part-1), Manufacture Name or monogram, Class: Heavy	As per Technical details		Rw
	<b>Rw-Documents review</b>	<b>Rv:Random verification</b>			

#### 8.4 Brass Fitting for Meter Inlet and Outlet adapter and suitable connector

##### MATERIAL

- The material used for the manufacturer of Brass fittings shall conform to IS319 :2007 ( Latest edition)
- Material used for Brass Fitting shall be Clean, Smooth, and free from the surface defects like blisters, Silvers, Scales, Fins, Spills, Cracks etc and FreeFrom internal defects like Porosity, Piping etc.

##### CHEMICAL PROPERTIES

Chemical composition of free cutting brass rods of Brass and its fittings shall be as mentioned in IS 319: 2007 with Head Chrome Plating.

##### HYDROSTATIC / PNEUMATIC PRESSURE TEST

All Brass fittings shall be sustaining the pressure of 3.5 bars for 30 minutes holding time during testing at site after installation and no leakage is permitted.

The test shall be performed on each size of the fittings at site after installation.

##### DIMENSIONAL TOLERANCES OF FREE CUTTING BRASS BARS, RODS AND SECTION

###### Sizes

The materials of Brass Fitting (Free Cutting Brass Rods) shall be supplied in sizes as specified in IS 319: 2007 or IS 2826 or as per Purchaser requirement.

###### Tolerances

The tolerances on sizes of bars/rods shall be as specified in IS 2826.

##### DIMENSION, WALL THICKNESS & TOLERANCE OF BRASS FITTINGS

Dimensions tolerances of various types of brass shall be as per drawing enclosed with tender (Drawing No.: TE-IND-STD-G-M-9018)

##### END CONNECTION

End connection of the brass fitting must be capable of end feeding to the NTP and as per drawing in tender (Drawing No.: TE-IND-STD-G-M-9018)

Internal solder ring type fitting is not acceptable.

##### FREEDOM FROM DEFECT

The fittings shall be free from internal fins, blow holes, skin defects etc. or other irregularities which might restrict the free flow of fluid, and shall be designed that resistant to the flow of fluid through the fittings is

minimized.

#### QUALITY ASSURANCE (QA)

The Contractor/Manufacturer /Vendor shall submit following for review of TPIA / EIC at the time of final inspection at contractor store before installation of materials.

- Material test certificates / reports
- Performance requirements and type test, if any.

#### INSPECTION / DOCUMENTS

- i. Inspection shall be carried out as per design codes/standards, OWNER Technical Specification and QAP enclosed in this tender by TPIA / EIC.
- ii. TPIA /EIC shall carry out final inspection at contractor store at the time of material acceptance / clearance before installation / work execution at site.
- iii. TPIA / EIC shall carry out random inspection during manufacturing/ final inspection.
- iv. Contractor / manufacturer / Supplier / Vendor shall furnish all the material test certificates, proof of approval/ license from specified authority as per specified standard, if relevant, internal test/inspection reports as per OWNER Technical Specification, at the time of final inspection of each supply lot of material.
- v. Even after third party inspection, OWNER reserves the right to select a sample of items randomly from each manufacturing batch/ lot and have these independently tested. If the results of these tests fall outside the limits specified in OWNER Technical specification, then OWNER reserves the rights to reject all production supplied from the batch.
- vi. For any control test or examination required under the supervision of TPIA/EIC, latter shall be informed in writing one (1) week in advance by vender about inspection date & place along with production schedule.

#### MARKING

Each fittings shall be embossed with manufacturers name and trade mark .

Each packing containing fittings shall carry the following stamped or written in indelible ink.

- a) Manufacturer's name or trade mark.
- b) Designation of fittings.
- c) Month and year of manufacturing

#### PACKAGING

Packing size to be mentioned to ensure uniformity in delivery conditions of the material being procured.

Contractor / manufacturer / Supplier / Vendor shall submit the packaging details and also complied with at the time of delivery.

#### DOCUMENTS OF PRECEDENCE

Where any portion of the documents is repugnant or variance with any provisions of the PTS, unless a different intention appears, the provision(s) of PTS shall be deemed to govern the provision(s) of documents of contract. If there is no variance or repugnance between documents and PTS both clauses shall be applicable.

In case of conflict between the requirements of this specification and that of the referred codes, standards and specifications, the requirements of the referred codes, standards and specifications shall govern.

QAP:

S. No	DESCRIPTION	Standard	DOCUMENTATION	INSPECTION	
				MFG. / CONTRACTOR	TPIA
1	Raw Material Inspection	AS Per IS319 / PTS	Material Test report	P	Rw
2	Dimensions and threads	As per technical	Dimension verification	P	Rw
3	Marking	As per technical	Marking	P	Rw

## 9 TECHNICAL SPECIFICATIONS FOR ELECTRO FUSION FITTINGS

### 9.1 SCOPE

This specification has been established to define the requirements that must be met by injected moulded polyethylene accessory destined for the construction or the maintenance of underground networks for natural gas distribution where the maximum operating pressure (MOP) is equal to 5 bars. It also defines some of the more general characteristics of materials used for accessory manufacturing and includes the appropriate classification model.

The specification also includes testing method parameters for the material in question. All PE accessory included in these specifications are listed as follows:

- Electrofusion welded PE accessory
- Electrofusion welded saddles
- PE accessory equipped with insertion connection for end to end welding and assembly using electrofusion-welded sleeve coupling.

PE and steel accessory with a tapered section and front section connections are not included in these specifications.

This specification is based on the series of EN 1555 standards, which standardize all the gas distribution network plastic piping systems.

The fittings described in this document comply with all prescriptions included in EN standard 1555-3, as well as all supplementary requirements and/or options described in this specification.

### 9.2 REFERENCE STANDARDS AND SPECIFICATIONS

<b>EN 682</b>	Air-tight rubber seals - specification for air-tight seal materials for gas and hydrocarbon fluid transfer piping
<b>EN 1555-1</b>	Plastic piping systems for combustible gas distribution. Polyethylene (PE). Part 1. General information
<b>EN 1555-3</b>	Plastic piping systems for combustible gas distribution. Polyethylene (PE). Part 3. PE accessory
<b>EN 1555-7</b>	Plastic piping systems for combustible gas distribution. Polyethylene (PE). Part 7. Conformity evaluation.
<b>ISO DIS 11413</b>	Preparation of test assemblies between a polyethylene (PE) pipe and an electrofusion fitting.
<b>ISO DIS 11414</b>	Preparation of test assemblies between a pipe/pipe or pipe/fitting polyethylene (PE) by butt fusion
<b>ISO DIS 12093</b>	Format for a technical brochure for electrofusion joint characteristics
<b>ISO TR 13950</b>	Electrofusion identification methods
<b>CEI 60335-1</b>	Safety standards for household appliances and similar equipment.
<b>CEI 364</b>	Electrical installations on buildings (including building sites and other temporary installations)
<b>CEI 449</b>	Voltage domains for building electrical installations.

### 9.3 DEFINITIONS & SYMBOLS

#### 9.3.1 Electrofusion Accessory

This term covers all injected moulded polyethylene accessory equipped with a heated element designed to transform electrical energy into heat to create self-welding.

In certain exceptional cases, an accessory can present one or more smooth ends. In this case the accessory will provide for the requirements of each connection end as regards shape, measurement, and technical characteristics.

### 9.3.2 Electrofusion Saddle

This term covers a saddle shaped injection moulded PE accessory that is equipped with one or several heating elements that convert electrical energy into heat. The released heat provides a fusion surface sufficiently large to ensure correct saddle-pipe assembly.

Electrofusion saddles can be subdivided into two categories:

Wrap around	Electrofusion saddle whose upper shell is brought against the pipe during welding using a fastening stirrup located on the lower part of the accessory to guarantee that the welding pressure is sufficient. Generally, the stirrup is left in place after welding.
Top load	Electrofusion saddle where the welding pressure is obtained by pressing down on the saddle head using a fixing system (clamp) that is removed after welding is completed.

### 9.3.3 End to End Welding PE accessory

This term describes injection moulded polyethylene accessory with smooth ends but not equipped with integrated heating elements. These are connected to the network by end-to-end welding using electrofusion sleeves.

In certain exceptional cases, an accessory can also present one or more electrofusion ends. In this case the accessory will provide for the requirements of each connection end in shape, measurement, and technical characteristics.

### 9.3.4 Lower Confidence Limit (LCL)

A quantity with the dimensions of stress, in mega pascal, which can be considered as a property of the material under consideration and represents the 97.5% lower confidence limit of the predicted long-term hydrostatic strength at a temperature of 20°C for 50 years with internal water pressure.

### 9.3.5 Minimum Required Strength (MRS 10)

Minimum Required Strength (MRS 10)

Standardized class of compounds for which the LCL is equal to 10.

### 9.3.6 PE 100

Standard designation for PE compounds in class MRS 10.

For such PE compounds, the long-term hydrostatic strength – calculated and classified according to the standardized method (ISO 9080 and ISO 12162) for a temperature of 20°C, a period of 50 years and a reliability of 97.5 % – must be at least 10 MPa.

### 9.3.7 Batch of Compound

By batch of compound means a homogeneous quantity of PE compound of the same origin and of a particular brand.

The batch must be registered under a single identification number (batch number) which leaves no doubt as to the origin, identity and date of manufacture of the compound.

## **9.4 MATERIALS**

### **9.4.1 General Information**

The materials used for the manufacturing of the PE accessory shall be SDR 11 & must conform to the requirements demanded for components used in gas fuel distribution networks.

The accessory material that is in contact with the PE piping must not be composed of any material that will provoke a reduction in pipe performance, nor must it provoke cracking under stress.

All equipment will be marked with inscription/description and specification in English language.

### **9.4.2 Raw Material Specifications**

The raw material PE, used for accessory production, is in compliance with all prescriptions in EN 1555-1 standards and belonging to class PE 100.

The raw material shall be virgin material only. The following are strictly forbidden:

- Use of recycled raw materials
- Mixing of different raw materials
- The addition of supplementary additives to the raw material.

A manufacturer that wishes to have a certain PE compound classified for the manufacture of PE gas components must submit a written application to Owner.

This application must be accompanied by a clear description of the compound concerned, including the following information:

- Name and class of the PE compound;
- Technical characteristics of the compound, with reference to the standard;
- A dossier with test results, from an independent laboratory, showing that the proposed compound meets the requirements of pr EN 1555-1 for a PE 100 compound. The dossier must also state which tests have been carried out on the same batch of pipes or test samples, including the identification of their origin.

All correspondence must be in English.

#### **9.4.2.1 Approved manufacturer for raw material**

- INEOS (Formerly SOLVAY)
- BOROUGE
- TOTAL PETROCHEMICALS
- DOW
- ELENAC
- BOREALIS
- LYONDELL BASELL

### **9.4.3 Specifications for Components Made of Materials Other Than Polyethylene**

#### **9.4.3.1 Metal parts**

All metal parts subject to corrosion must be protected in an adequate manner.

Metal parts must conform to prescribed standards of that particular material for gas distribution, for quality levels, size/gauge and measurements.

Cast iron, aluminium and its alloys are not authorised for use.

#### **9.4.3.2 Elastomers**

Elastomer air and watertight seals, like all other elements manufactured in this material, must comply with the prescriptions of EN 682 standards.

#### **9.4.3.3 Other materials**

All other materials used are in compliance with this specification. The PE accessory included in the paragraph comply with the requirements of this specification and are adapted for all general use for natural gas distribution.

## **9.5 GENERAL CHARACTERISTICS OF PE ACCESSORY**

### **9.5.1 Technical Information**

The manufacturer must supply a technical information dossier composed and including the same material and presented in the same manner, in compliance with the prescriptions of the ISO DIS standard 12093.

This dossier must mention all the following information for each accessory:

- PE raw material used
- Measurements and tolerances
- Domain of application (temperature and pressure limits, SDR and ovalisation)
- Assembly instructions
- Welding instructions (welding parameters and limits)
- Test results attesting to the accessory conformity standard: c.f. EN standard 1555-3 for test descriptions.

For electrofusion PE accessory, the manufacturer must also supply the SDR series for the pipes, which will be used together with their accessory, according to their thickness.

In addition, for the saddles:

- The attaching method (tools necessary and/or lower shell)
- saddle category (refer to 3.2)
- Maximum saddle height (H in figure 2)
- the height of the branch pipe for supports (h in figure 2)

For all smooth ended PE accessory, the manufacturer must also supply the SDR 11 series of connections; the accessory must be guaranteed for use on piping of the same class.

In the case of welding parameter modification, size or raw material changes, the manufacturer must include a new technical dossier providing proof that the accessory in question is still compliant with the specification prescriptions.

Testing assemblies will take into consideration manufacturing tolerance, assembly tolerance and the variations in environmental temperature corresponding with the conditions where the PE accessory will be in use. The manufacturer must observe all methods recommended for polyethylene accessory installation as shown in the Tractebel specifications.

The assembly of piping and fittings manufactured and used in the tests must be in compliance with the manufacturer's technical instructions and the limits of use conditions. When the test assemblies are carried out, the manufacturing and assembly tolerances must be taken into consideration. Samples destined for assembly testing with electrofusion PE accessory must be prepared according to standard ISO DIS 11413. End-to-end welded samples must be prepared according to standard ISO DIS 11414.

### **9.5.2 Appearance and Finish**

The internal and external surfaces of the PE accessory must be smooth, clean and free of all scratching, pitting and other surface faults that can possibly reduce accessory and assembly performance.

No element of any accessory must show any signs of damage: scratching, scraping, piercing, blisters, bloating, denting, holes, cracks or other faults that can reduce required performance.

It must be possible to place the accessory on the pipe or on another accessory without moving the electric winding or the air/water tight seals etc. and this must respect the tolerance permitted for piping and PE accessory.

### 9.5.3 Colour

All fittings shall be of black colour.

### 9.5.4 Join Appearance

After welding, when examined visually without a magnifying glass, the internal and external surfaces of the pipes and PE accessory must appear free of welding exudation outside the accessory limits (unless identified by the accessory manufacturer as normal, or carried out deliberately as a welding test, but on condition that there is no wiring position change inside the electrofusion PE accessory that could provoke

a short-circuit). Internal surfaces of all adjacent piping must remain identical to the previous condition before welding.

### 9.5.5 Electrofusion Accessory and Electrical Characteristics

#### 9.5.5.1 General information

The PE accessory include an electrical system as described in the standards CENELEC 60335-1, CEI 364 and CEI 449.

This system is equipped with an appropriate electrical protection for the voltage and intensity of the current in use and adapted to the characteristics of the electrical supply line.

For voltage over 24 V protection is essential against direct contact with the active parts (conductors on line). The type of protection in question depends on the local site conditions.

#### 9.5.5.2 Connectors

Connector (terminal pin) 4.0 mm/4.7mm shall be required.

#### 9.5.5.3 Protection against overheating

Electrofusion PE accessory that can only be welded once are equipped with a lock system which prevents re-welding.

Electrofusion PE accessory that cannot be re-welded immediately after initial welding are equipped with an incorporated security system in their welding program: that is, they cannot weld while the wire is still hot.

If the welding program does not possess this lock system, the electrofusion accessory must absolutely be protected against a second or several welding cycles whatever the temperature of the winding wire.

### 9.5.6 Support Drilling Equipment

The support drilling equipment to be designed so that during drilling the maximum immediate leak flow will never exceed 200 litres per hour at 5 bar pressure, in the main pipe. According to this flow rate, the supports are divided into two categories:- models 1 and 2 (refer to par. 3.2.) The required model will be specified when ordered.

The bell drill is equipped with a maneuver opening for the insertion of a requisite (range may vary from 5 mm to 21mm) hexagonal spanner/Allen Key.

The bell drill path is limited at the top by a limit block.

The drill mechanism is designed so that no additional tools (except the hexagonal spanner/Allen Key) are required for carrying out drilling operations. On placement of order the proposed sizes of hexagonal spanner/Allen Key required for various sizes of Tapping Saddle shall be informed by the bidder along with drawing of particular saddle for approval of Owner.

## 9.6 GEOMETRICAL CHARACTERISTICS

### 9.6.1 Size of Electrofusion Sleeves

The sizes of the electrofusion accessory sleeves and their tolerance limits are described in chapter “Geometrical characteristics” of EN standard 1555-3.

They are controlled according to the method described in the specification standard. Any possible sealing plugs are removed from the sleeve 4 hours before the size control check. Measurements are controlled without the plugs inserted.

The main symbols are shown in the figure 1 below:

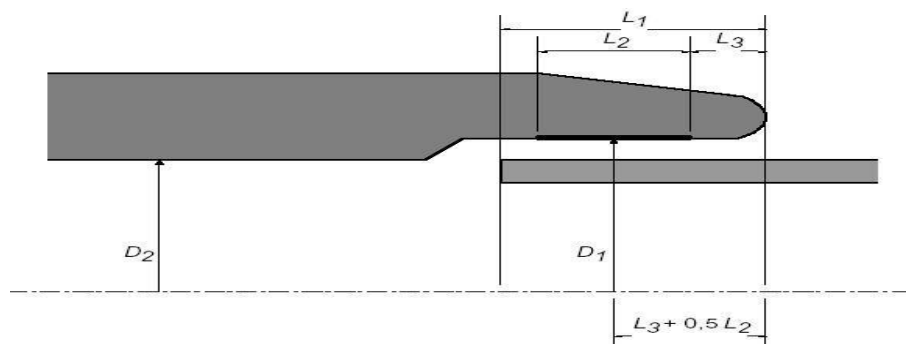

Figure 1

The “average internal diameter in the welding zone” – that is: the average internal diameter measured in a parallel plane to the opening plane, at a distance of  $L_3 + 0.5L_2$  of the latter.

“Minimum drilling/boring” – that is the minimum diameter of the draining canal through the body of the accessory.

“penetration depth” of the pipe or the inserted (male) end of the accessory

“Nominal length of the welding zone” that corresponds with the length subject to heating.

“Nominal non-heated entry/inlet length of the sleeve”. This refers to the distance between the tip of the accessory and the beginning of the welding zone.

### 9.6.2 Electrofusion Saddle Measurements

The measurements of the electrofusion saddles and their tolerance limits are described in EN standard 1555-3

They are controlled according to the method described in the specification standard. Any possible sealing plugs are removed from the sleeve 4 hours before the size control check. Measurements are controlled without the plugs inserted.

The main symbols are shown in the figure 2 below:

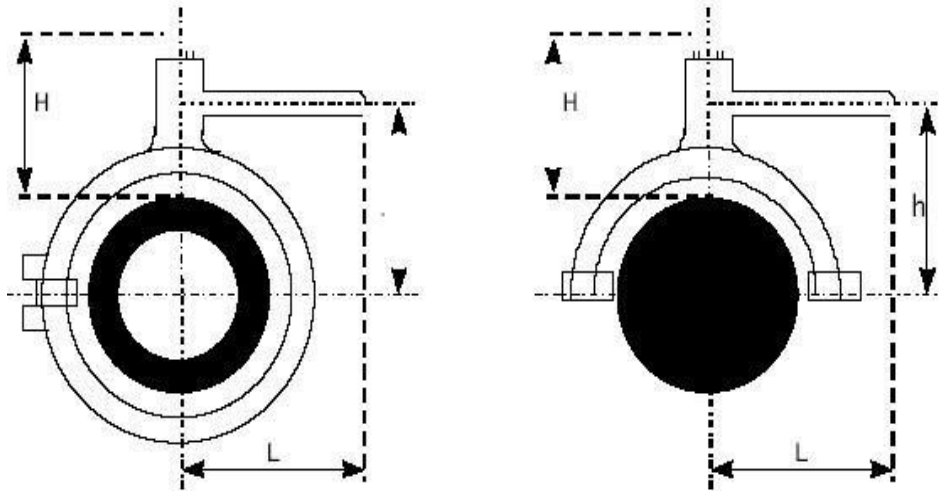

- H The “height of the saddle” – that is the distance between the upper generator of the main pipe and the top of the branch pipe saddle
- h The “height of the branch pipe” – that is the distance between the axis of the main pipe and the axis of the branch pipe
- L The “width of the branch pipe saddle” – that is the distance between the axis of the pipe and the surface plane of the branch pipe opening

### 9.6.3 Measurements of Accessory Ends to Be Welded

The measurements of the ends and their tolerance limits are described in EN standard 1555-3.

They are controlled according to the method described in these specification standards. Any possible sealing plugs are removed from the sleeve 4 hours before the size control check. Measurements are controlled without the plugs inserted.

The measurements and main symbols used in this specification are shown in the figure 3 below:

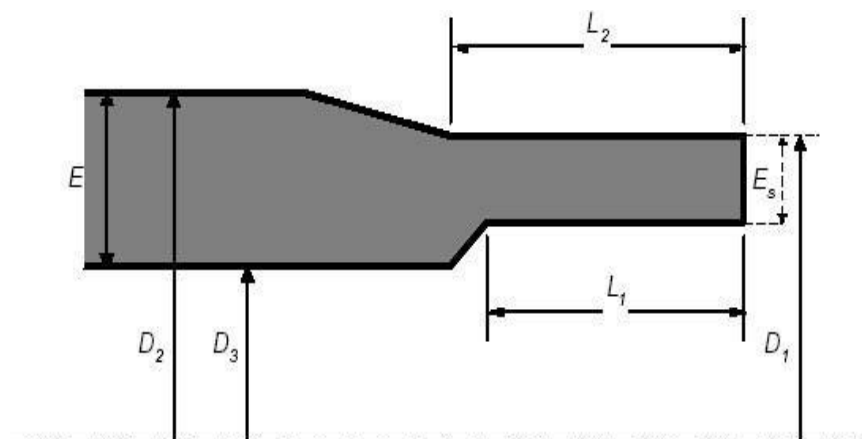

D1 The “average external diameter of the end to be welded measured on any plane parallel to the inlet/entry plane at a distance where this plane does not exceed  $L_2$  (tubular section).

D2 The “average external diameter of the body” of the tip of the accessory.

D3 “Minimum drilling/boring” – that is the minimum diameter of the passage through the body of the accessory. Measuring of the diameter must not include any ribbing due to welding.

E “ Thickness of the accessory body wall” – that is: the thickness measured at any point of the accessory wall.

ES “Thickness of the end to be welded” measured at any point but where the distance does not exceed L1 (length that can be cut) compared to the inlet/ entry plane, must be equal to the thickness of the nominal pipe wall.

L1 The “cuttable section” of the end to be welded – that is the initial depth of the tip of the insertion section, necessary for end-to-end welding or for starting an end-to end weld again.

L2 The “tubular section” of the end to be welded – that is the initial length of this section. This tubular section permits the following in all types of combination:

- o Use of the clamp stirrups, as is essential for end-to-end welding, or for electrofusion.
- o Assembly using electrofusion sleeves.

## **9.7 MECHANICAL CHARACTERISTICS**

All PE accessory must obey the requirements and tests described in the chapter concerning the mechanical characteristics of EN standard 1555-3. They must also comply with the hydrostatic test conditions described in the same standard.

They must be controlled as described in the same standard.

## **9.8 PHYSICAL CHARACTERISTICS**

All PE accessory must obey the requirements and tests described in the chapter concerning the mechanical characteristics of EN standard 1555-3.

They must be controlled as described in the same standard.

## **9.9 PRODUCT APPROVAL**

The product will be approved by the Owner if all results of the tests, controls and checking prescribed by this specification are satisfying.

The manufacturer will provide a complete approval dossier including all the product characteristics specified in 5.1. (Technical dossier) and the results of tests prescribed in these specifications. The number of tests run on the product must comply with EN standard 1555-7. The results of these tests described in the approval dossier must be confirmed by the Owner authorised laboratory. Hydraulic testing must be continued until the rupture of at least two test samples for each set of tests. (max. 2000 hours).

All changes made to the approved product must be communicated to the Owner, and this entails further control checks for approval.

Any requirement not observed or test missing from this specification will result in the withdrawal of the product approval and can even result on annulment of contract.

## **9.10 MARKING**

### **9.10.1 Accessory Marking**

- 9.10.1.1 Identification marking will be made directly on the accessory. The system used to make the product must not provoke cracking or other faults. All marking must be permanently

legible for the product life under standard stocking conditions, exposure to external weather conditions, treatment, installation, and use.

- 9.10.1.2 Where the products are printed, the colour of the printed identification mark must be different from that of the basic product colour.
- 9.10.1.3 Marking quality and size must be of a standard that can be read with the naked eye without magnification. No marking must be printed on the minimum length of the insertion section of PE accessory.
- 9.10.1.4 Each accessory must be marked with at least the obligatory details required by EN standard 1555-3. The marking must be printed on the accessory itself or on a label as shown in the standard described above
- 9.10.1.5 The SDR pipe range that are to be fitted with these PE accessory must be clearly marked on the fitting. Details must include: each SDR value, or the upper and lower value of the permitted SDR range.

#### 9.10.2 Supplementary Information

All supplementary information on welding conditions (welding time and cooling time) can also be described on a label affixed to the accessory or delivered with the accessory.

### 9.11 PACKAGING AND DELIVERY

All electro fusion PE accessory must be printed with a bar code or bar code with an individual magnetic card (manual setting information for data transfer purposes must be supplied in bar code). The magnetic card contains the welding parameters that have been encoded in the magnetic track, as well as the bar code printed on the card. Coding must be carried out according to prescriptions included in ISO TR 13950 standards. The bar codes shall be laminated to ensure that the details are not damaged or erased.

### 9.12 QUALITY CONTROL

#### 9.12.1 General Rulings

##### 9.12.1.1 Manufacturer's responsibility

The manufacturer is entirely responsible for the quality of the PE PE accessory manufactured by his firm. All control checks prescribed above do not relieve him of this responsibility.

To ensure that all PE PE accessory are in compliance with the specification in all aspects, they must be controlled by the plant control service, which must be independent from the manufacturing department.

All PE PE accessory supplied are guaranteed for a one-year period after application for use that is a maximum of three years after the date of production.

##### 9.12.1.2 Quality assurance

The manufacturer must have some form of quality control to ensure that products comply with EN standards 29001 or 29002. The quality assurance manual must be made available to the Owner Control Service or an external Control laboratory appointed by him.

The system of quality assurance must be certified by an authorised body.

#### 9.12.2 Controls

##### 9.12.2.1 Control testing by the manufacturer

###### 9.12.2.1.1 By material batch.

The manufacturer demands a certificate from the raw material manufacturer including the following:

- Fluid index
- Water content
- Volume mass

- Carbon black or yellow stabilising agent content
- OIT value (thermal stability)

#### 9.12.2.1.2 By accessory batch

The manufacturer must run control checks as follows:

- Appearance / colour
- Measurements
- Hydraulic testing
- Electrical resistance
- Printing/marketing.

Control checks and the number of tests must be carried out according to the prescriptions of the EN standard 1555-3

Also refer to Table No 8, paragraph 4.2.3. "Batch/Lot release tests" of EN standard 1555-7.

The results must be written out in documents that contain the complete identification of the accessory batch.

These documents must be made immediately available for the Owner representative.

#### 9.12.2.2 Plant Reception by the Owner Control Service representative

##### 9.12.2.2.1 General information

All quality controls must be run in the presence of the Owner Control Service representative.

All tests and control checks must comply with appropriate standard prescriptions and with the specific specifications established with the order.

At each visit by the Owner representative, the manufacturer must provide, free of charge, all means and personnel necessary for running the established control checks.

While the order is under production, the Owner representative must have access to stocking installations of all raw materials before manufacturing, manufacturing and control installations, as well as the accessory stocking areas for any control checks he is responsible for.

During his visits, the Owner representative will receive a certificate as soon as he reaches the plant for each batch of PE accessory presented for reception.

Each time this is requested by the Owner representative, the manufacturer must provide recent reports of all control checks and measuring instrument results and testing results.

##### 9.12.2.2.2 Convocation for reception

Convocation instructions for reception are to be defined with the order.

##### 9.12.2.2.3 Reception control checks

The control checks and tests are to be run according to the prescriptions of EN standard 1555-3

#### 9.12.3 Acceptance or Refusal

##### 9.12.3.1 Appearance, measurements and marking

Any requirements not supplied will lead to the refusal of the complete batch. However,

in the case where a batch is refused, it can be presented for approval again after a control check, on agreement with the Owner Control Service.

### 9.12.3.2 Control check on characteristics

All results that do not comply with the specification prescriptions and the particular specifications requested with the order, demand counter-testing on at least double the number of the samples previously tested. If the undesirable result is confirmed, then the batch is refused permanently. If the result is positive, then the batch will be accepted.

As a complementary control check, other analyses and/or tests can be run after common agreement, and at the manufacturer's cost.

## ANNEX 1

### CONNECTOR FOR ELECTROFUSION PE ACCESSORY

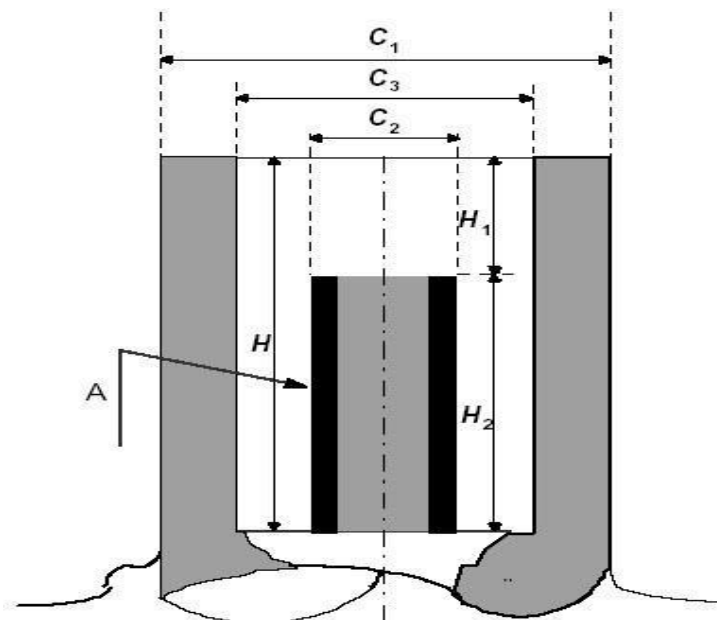

### SYMBOLS

	External diameter of connector	$C_1 \geq 11,8 \text{ mm}$
	Diameter of active part of connector	$C_2 = 4,00 \pm 0,03 \text{ mm}$
	Internal diameter of connector	$C_3 = 9,5 \pm 1,0 \text{ mm}$
	Connector internal depth	$H \geq 12,0 \text{ mm}$ $H \geq H_1 + H_2$
	Distance between upper part of connector and active part	$H_1 = 3,2 \pm 0,5 \text{ mm}$
	Height of active part	$H_2 \geq 7 \text{ mm}$
	Active zone.	

**RECEPTION AT MANUFACTURER'S PLANT.**

<b>Characteristics</b>	<b>Reference EN 1555-3</b>	<b>Minimum drill tests / frequency</b>	<b>No of samples</b>	<b>No of measure/ samples</b>
Appearance /colour	5.2 /5.3	1 x /size / product type / internal space	10	1
Measurements	6	1 x /size / product type / internal space	10	1
Thermal stability (OIT)	8.2	1 x batch	1	1
Melt mass/flow rate (MFR)	8.2	1 x batch	1	1
Electrical resistance	5.6	1 x /size / product type / internal Space	5	1
Cohesion resistance	7.2	1 x /size / product type	2	1
End-to-end seam resistance to traction (cohesion resistance)	7.2	1 x /size / product type	2	1
Shock resistance	7.2	1 x /size / product type	1	1
Load loss	7.2	1 x /size / product type	1	1
Marking	10.2	1 x /size / product type	1	1

**Drawing :-**

**Technical drawing layout of chamber , SV , IV , Pedestals etc attached as Separate file**